



**MODEL OVL-II™ SEBP**

**Barrier-Free Fountain**



This fountain is certified to NSF/ANSI 61.

**GENERAL**

Two oval shape fountains, one-piece, non-corrosive stainless steel with brushed satin finish. Contour-formed basins with rounded corners and edges reduces splatter, insures proper drainage and prevents standing waste water. Oval fountain shape requires less neck extension and bending for the wheel chair user. Designed to be easily accessible to both physically challenged and able-bodied individuals. Ideally suited for installation in public areas. Model meets state and federal requirements as defined by the Americans with Disabilities Act.

**BUBBLER**

Exclusive one-piece, chrome-plated two-stream mound-building bubblers with non-removable anti-squirt feature and integral hood insures a satisfying drink of water.

**PUSH BAR ACTUATION MECHANISM**

Self-closing, semi-circular push bar can be actuated at any point of its 180° radius.

**PANEL**

Constructed of stainless steel, number 300 series with satin finish.

**AUTOMATIC STREAM HEIGHT REGULATOR**

Self-closing assembly is located inside unit to prevent tampering. Unit resists corrosion and liming. A constant stream height is automatically maintained under line pressures that vary from 20 to 105 psi.

**INLET STRAINER**

Easily cleaned in-line strainer screen traps particles of 140 microns or larger before they enter the waterway.

**WATER INLET**

3/8" O.D. Tubing

**DRAIN OUTLET**

1-1/4" tube outlet for 1-1/4" slip joint connection.

**SUGGESTED SPECIFICATIONS**

Both fountains shall include pushbar on the front. Both shall include contour-formed basins to eliminate splashing and standing water, and shall have rounded corners and edges. Each projector shall be two-stream, mound-building type with integral hood guard and anti-squirt feature. Fountain shall comply with ANSI 117:1 and ADA for visual and motion disabilities. The manufacturer shall certify the unit to meet the requirements of ANSI/NSF 61, and the Safe Drinking Water Act.

Note: Continued product improvement makes specifications subject to change without notice. See Halsey Taylor website for most current spec sheet.



**Standard Finish is Stainless Steel**

**Optional Finishes (extra cost)**

- Aztec Gold
- Galaxy Gray Marblyte™ (Bowl Only)
- Black Onyx Marblyte™ (Bowl Only)

**Optional Accessories (extra cost)**

- Vandal-Resistant Kit
- Easy-Flex™ Bubbler
- Cane Apron
- Water Filter (2 recommended)

**Each OVL-II™ SEBP consists of 1 carton of the following:**

Fountain, Panel and Misc. Parts

**Trap and service stop not included.**

Copper tube to water supply connection not furnished

**Shipping weight:** 55 lbs.

JOB NAME: \_\_\_\_\_  
 \_\_\_\_\_  
 \_\_\_\_\_  
 ENGINEER/CONTRACTOR NAME:  
 \_\_\_\_\_  
 APPROVAL: \_\_\_\_\_  
 DATE: \_\_\_\_\_



## OVL-II™ SEBP

# OVL-II™ Barrier-Free Bi-Level Fountain

(CONTINUED)

### MOUNTING INSTRUCTIONS

Refer to diagrams for rough-in of plumbing. Mount wall plate assembly to wall per the installation instructions. Hang fountain panel over the wall plate assembly. Attach fountains to wall plate assembly. Water service line and waste line are to be assembled as required. Final check for leaks and correct functions of fountain should be made. (For details see the installation instructions.)

**Installation requires trap to be installed in wall. A service supply stop must be installed at the fountain inlet line. Trap and service stop not included.**

**CAUTION – Fountain must be securely bolted to wall.**

For wall support required locations see installation instructions provided with panel and fountains.

### OPERATING PRESSURES:

Supply water - 105 psi maximum

## TOP VIEW

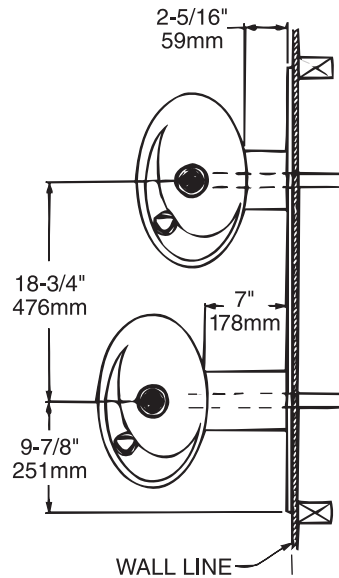

## SIDE VIEW

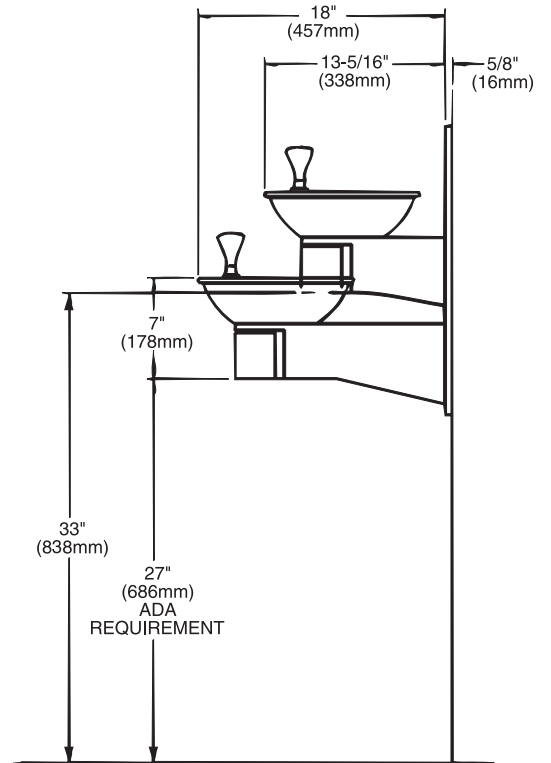

## WALL LAYOUT

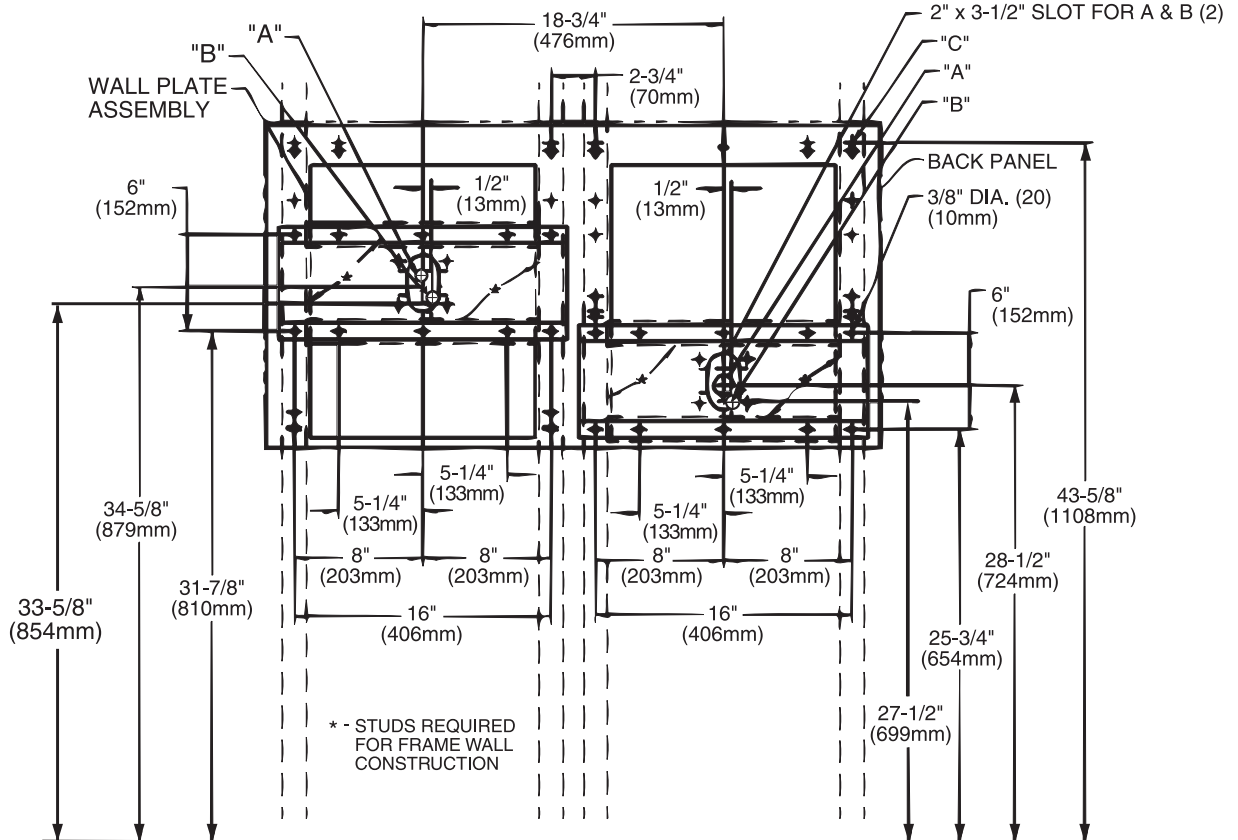

### LEGEND:

- A = 1-1/4" O.D. WASTE TUBE (TRAP AND ELBOW NOT PROVIDED)
- B = 3/8" O.D. UNPLATED COPPER TUBE CONNECT (WATER INLET)
- C = 1/4" (6mm) DIA. HOLES FOR MOUNTING PLATE TO WALL

\*ADA Requirement

**Halsey Taylor®**