

# 1001HPSBP

Wall Mounted Drinking Fountain



## FEATURES & BENEFITS

### Quality Control

Fountain is pre-built and fully water and pressure tested to ensure no leaks and proper function for reduced installation time and added peace of mind.

### Construction

18 gauge Type 304 Stainless Steel fountain with attractive and functional swirl bowl design, along with a vandal-resistant bottom plate provides a long lasting unit with added peace of mind.

### Bubbler Head

Polished chrome-plated brass bubbler head with integral laminar flow prevents splashing and provides a superior flow pattern. The integral basin shank and inserted roll pin adds vandal resistance strength to the design, and the shielded angled stream orifice produces a steady sanitary source of water.

### Push Button

With its patented (Pat.# 6,981,692) push-button valve assembly which allows for front access stream adjustment as well as cartridge and strainer access, this fountain offers the ultimate in ease of maintenance.

### Mounting

3/16" steel mounting plate with supplied mounting hardware provides a solid unit base and allows for easy installation to a framed wall. (P-trap and stop require rear access)



## SPECIFICATIONS

Model 1001HPSBP wall mounted barrier-free drinking fountain shall include an 18 gauge Type 304 high-polished stainless steel finish basin with integral swirl design, with matching back panel, push-button operated valve with front-accessible cartridge and flow adjustment, polished chrome-plated brass vandal-resistant bubbler head with integral laminar anti-squirt flow, chrome-plated brass vandal-resistant waste strainer, vandal-resistant bottom plate, and 1-1/4" O.D. waste pipe. (P-trap and stop require rear access)

## OPTIONS

- Bubbler Head: Model 5725 EnviroGard™ bubbler is a polished chrome-plated solid brass bubbler head with stainless steel water activated pop up canopy. (Pat.# 7,025,282)
- Filter: Model 6426, 12" x 2", in-line lead removal element that reduces lead from incoming water supply.
- Access Panel: Model 6603HPS, high polished stainless steel finish access panel. Includes frame and screws.
- Support Carrier: Model 6800 universal in-wall mounting support for use with most fountains.

To see all options for this model, visit [www.hawesco.com](http://www.hawesco.com).

## APPLICATIONS

Perfect for either public or private indoor/outdoor settings, Model 1001HPSBP is a great fit in areas where aesthetics are important to the overall appeal of the architecture. This series is precisely mounted, making it a nice addition to any surrounding. Beautiful high-polished finish helps to maintain the fountains overall appeal so it always remains looking as new as it did when it was installed. Specifically, this type of wall mounted drinking fountain may be placed in settings such as: schools and other locations in and around office buildings where the temperature remains above freezing.

Model meets all current Federal Regulations for the disabled including those in the Americans with Disabilities Act. Haws manufactures drinking fountains, electric water coolers and electric drinking fountains to be lead-free by all known definitions including ANSI/NSF Standard 61, Section 9, California Proposition 65, and the Federal Safe Drinking Water Act.







## INSTALLATION, OPERATION & MAINTENANCE INSTRUCTIONS

1455 Kleppe Lane ♦ Sparks, NV 89431-6467 ♦ (775) 359-4712 ♦ Fax (775) 359-7424  
HAWS AG ♦ Bachweg 3 ♦ CH-3401 Burgdorf ♦ Switzerland  
Haws Mfg. Pte Lt. ♦ 74 Sungei Kadut Loop ♦ Singapore 729531  
E-mail: [haws@hawsco.com](mailto:haws@hawsco.com) ♦ website: [www.hawsco.com](http://www.hawsco.com)

No. 2076304(7)

### Model 1000/1001/1001HPS Drinking Fountain

**NOTE TO INSTALLER:** Please leave this information with the Maintenance Department.

#### LIMITED WARRANTY

HAWS warrants that all of its products are guaranteed against defective material or poor workmanship for a period of **one year from date of shipment**. HAWS liability under this warranty shall be discharged by furnishing without charge F.O.B. HAWS Factory any goods, or part thereof, which shall appear to the Company upon inspection to be of defective material or not of first class workmanship, provided that claim is made in writing to company within a reasonable period after receipt of the product. Where claims for defects are made, the defective part or parts shall be delivered to the Company, prepaid, for inspection. HAWS will not be liable for the cost of repairs, alterations or replacements, or for any expense connected therewith made by the owner or his agents, except upon written authority from HAWS, Sparks, Nevada. HAWS will not be liable for any damages caused by defective materials or poor workmanship, except for replacements, as provided above. Buyer agrees that Haws has made no other warranties either expressed or implied in addition to those above stated, except that of title with respect to any of the products or equipment sold hereunder and that HAWS shall not be liable for general, special, or consequential damages claimed to arise under the contract of sale. The drinking fountain manufactured by HAWS is warranted to function if installation and maintenance instructions provided are adhered to. The units also must be used for the purpose for which they were intended.

**NO OTHER WARRANTIES EXPRESSED OR IMPLIED ARE AUTHORIZED, PROVIDED OR GIVEN BY HAWS.**

**SHOULD YOU EXPERIENCE DIFFICULTY WITH THE INSTALLATION OF THIS MODEL, PLEASE CALL:**

# 1-800-766-5612

**(U.S.A. AND CANADA ONLY) MONDAY-THURSDAY: 6:00 A.M. – 4:00 P.M. PST  
FRIDAY: 6:00 A.M – 1:00 P.M. PST**

**RECOMMENDED TOOLS:** Hack saw, pipe joint sealant, screwdriver, level, 12" adjustable wrench, 10" pipe wrench, 3/32" and 5/32" hex key wrench, 9/16", 1/2", 7/16" socket wrench or open end wrench.

**LOCATION OF UNIT:** The Model 1000/1001/1001HPS Drinking Fountain is a wheelchair accessible drinking water facility. The height dimensions shown, meet current ADA requirements. When installing this unit, local, state or federal codes should be adhered to. If height other than shown is required, then dimensions must be adjusted accordingly.

**SUPPLY LINE:** The minimum recommended line size is 1/2" IPS with 30-90 PSI (2-6 ATM) flowing pressure. Where sediment or mineral content is a problem, an inlet filter is recommended.

**PLUMBING CONNECTIONS:** Inlet is 3/8" O.D. compression fitting. Waste elbow outlet is 1-1/4" O.D. tube.

**MAINTENANCE:** Periodically clean the strainer. Refer to 5874 Valve Manual for more information.

## CLEANING INSTRUCTIONS FOR GOLD PLATED PRODUCTS

Haws recommended cleaning procedure for gold plated products is as follows: **Caution...** This Haws product is gold plated. Clean with a non-abrasive cleaner. Use a soft 100% cotton cloth with a mixture of one part lemon juice and one part water, vinegar, or a commercial glass cleaner. Do **not** use an abrasive cloth, brush, polishing compound or abrasive cleaner.

## TROUBLESHOOTING

PROBLEM	REPAIR CHECKLIST
1. Insufficient bubbler flow.	<ul style="list-style-type: none"><li>1a. Check that inlet screwdriver stop valve is in wide-open position.</li><li>1b. Verify minimum 30 psi flowing supply pressure.</li><li>1c. Clean strainer. See 5874 Valve Manual.</li><li>1d. Adjust valve to increase flow. Use front adjust screw or see 5874 Valve Manual.</li></ul>

THIS DOCUMENT AND THE DATA DISCLOSED HEREIN OR HEREWITH IS NOT TO BE REPRODUCED, USED, OR DISCLOSED IN WHOLE OR IN PART TO ANYONE WITHOUT THE PERMISSION OF HAWS CORPORATION.

REVISIONS					
ZONE	REV	DESCRIPTION	ECN	DATE	BY
	7	CHANGED 5872 VALVE AND COMPONENTS TO THE 5874 VALVE.	3341	12/18/02	MD

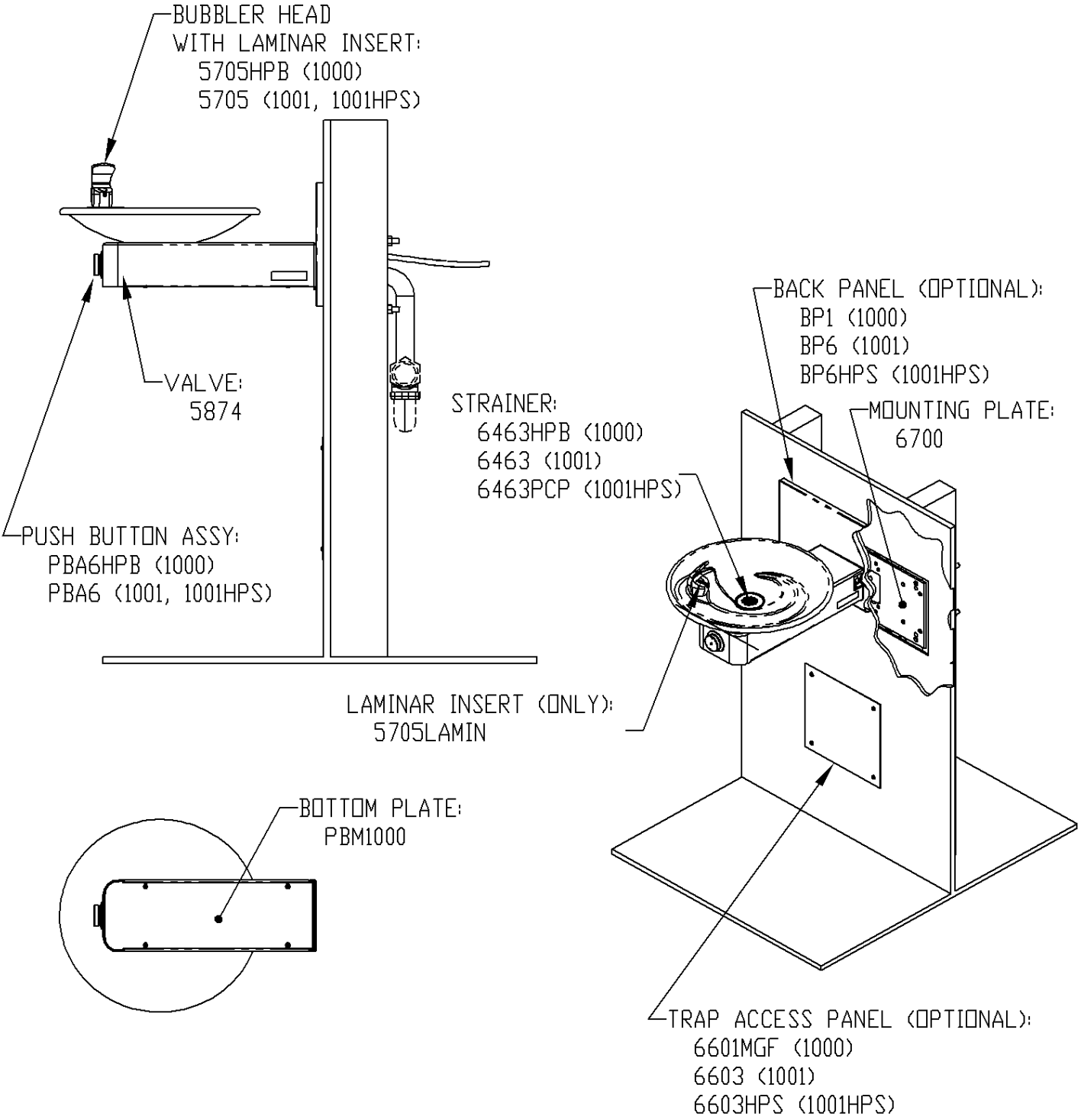

**PARTS BREAKDOWN**

WHEN ORDERING PARTS PLEASE SPECIFY YOUR MODEL NUMBER

ECN NO. 2392				
APPROVALS	DATE			
DRAWN RM	10/19/98	1455 KLEPPE LN SPARKS, NV	BAOHWEG 3 CH3401 BURGDORF SWITZERLAND	www.hawsco.com 775-359-4712
CHECKED		TITLE MODELS 1000/1001/1001HPS		
APPROVED		SIZE PART NO. A 0002076304	REV. 7	
DO NOT SCALE DRAWING	SCALE: NONE	PARTS BREAKDOWN	SHEET 1 OF 1	

NOTES:

1. HOLD ROUGH-IN DIMENSIONS ±1/8" (3.2mm).
2. WHEN INSTALLING THIS UNIT, LOCAL, STATE, OR FEDERAL CODES SHOULD BE ADHERED TO FOR INSTALLATION DIMENSIONS (LOCATIONS), WASTE AND SUPPLY REQUIREMENTS OTHER THAN SHOWN.
3. INSTALLER MUST PROVIDE TRAP FOR PROPER INSTALLATION. REMOVE VALVE FROM PUSH BUTTON TO INSTALL WASTE ELBOW INTO BOWL. AFTER WASTE ELBOW IS INSTALLED, REINSTALL VALVE AND ADJUST FLOW.
- 4.

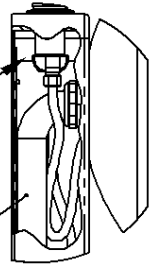

DETAIL C  
1-1/4" WASTE BEND (SUPPLIED)  
4

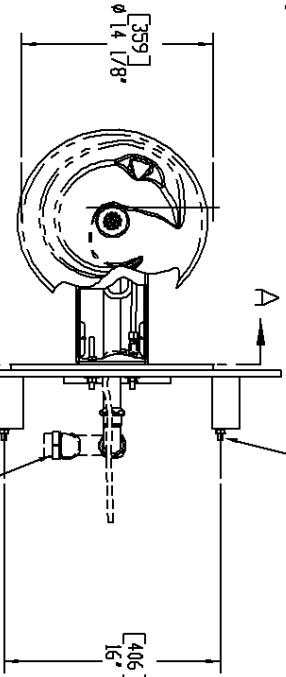

SECTION A-A  
MOUNTING BOLTS (BY OTHERS)  
WALL FACE  
WALL STUD  
1-1/4" IPS WASTE ELBOW AND TRAP (BY OTHERS)  
18 5/8"  
16"  
359"  
14 1/8"  
WALL FACE

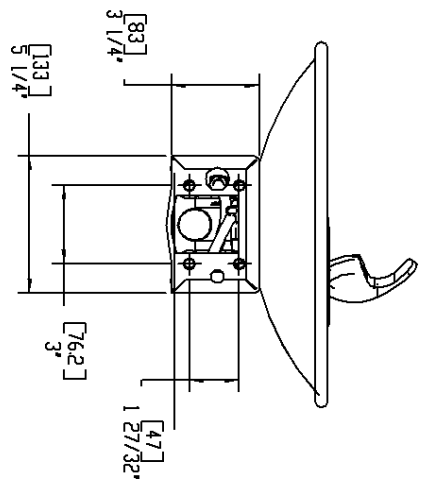

SECTION A-A  
ROTATED 90° CW  
BRACKET MOUNTING  
DETAIL

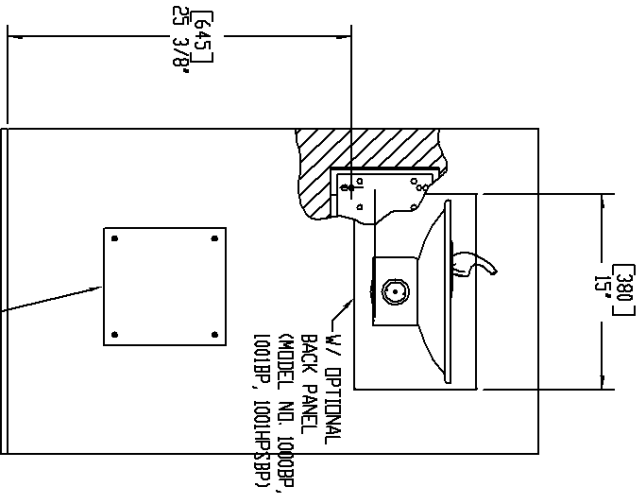

OPTIONAL TRAP ACCESS PANEL  
MODELS 660MGF,  
6603 AND 6603HPS

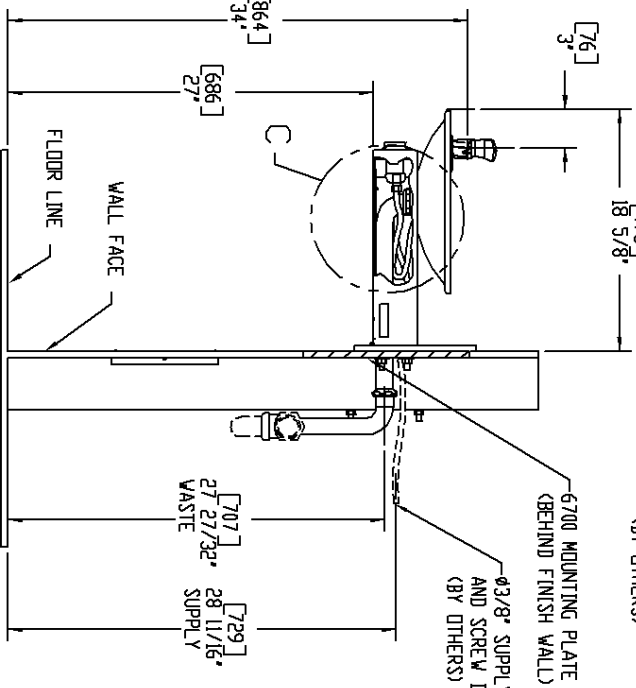

6700 MOUNTING PLATE (BEHIND FINISH WALL)  
WALL FACE  
FLOOR LINE  
76"  
18 5/8"  
27"  
27 27/32" WASTE  
28 11/16" SUPPLY  
707"  
729"  
3/8" SUPPLY TUBING AND SCREW DRIVER STOP (BY OTHERS)  
4X 3/8"-16 UNC

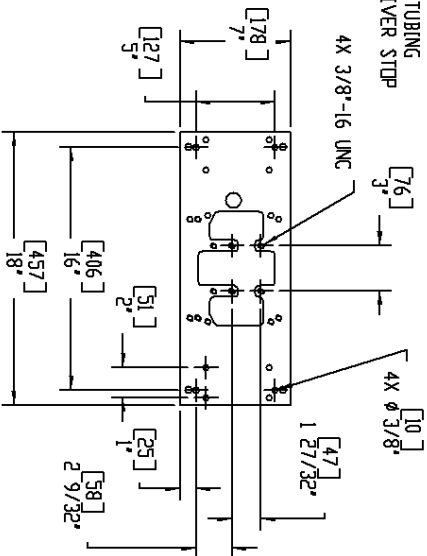

6700 MOUNTING PLATE  
MUST BE INSTALLED BEFORE  
FINISH WORK. THIS PLATE IS A  
STANDARD ITEM.

PROJECT NO.	DATE	TITLE	SCALE	DATE	SCALE	DATE	SCALE
EXH. 344	1/10/02	DRINKING FOUNTAIN	1/4" = 1'-0"	12/15/02	1/4" = 1'-0"	12/15/02	1/4" = 1'-0"
REV.	DATE	BY	CHKD.	DATE	BY	CHKD.	DATE
1	1/10/02			12/15/02			12/15/02
PROJECT NO.		DATE		TITLE		SCALE	
0002076304.D		1/10/02		DRINKING FOUNTAIN		1/4" = 1'-0"	
REV.		DATE		BY		CHKD.	
7		1/10/02				12/15/02	

1455 Klegan Ln, Sparks, NV, 89431  
 Phone: 775-359-4712 Fax: 775-359-7124  
 Harsig Building 2 0th-3rd, Burlington, Switzerland  
 Harsig Bldg, The Land 74, Singapore Road, Singapore 729381  
 e-mail: harsig@harsig.com website: www.harsig.com

INTL. FAX: 1-888-FAX-4445-D-888-329-42971