



**MODEL HDFBLEBP**

**Barrier-Free Fountain**



This fountain is certified to NSF/ANSI 61.

**GENERAL**

Two face-mounted 14 gauge heavy duty fountains, one-piece, non-corrosive stainless steel number 300 series with brushed satin finish and one piece vandal resistant drain. Larger seamless drawn contour-formed basins with softly rounded corners and edges reduce splatter, insures proper drainage and prevents standing waste water. Designed to be easily accessible to both physically challenged and able-bodied individuals. Ideally suited for installation in public areas. Model meets state and federal requirements as defined by the Americans with Disabilities Act **for both children and adults.**

**BUBBLER**

Vandal resistant bubbler is one-piece chrome plated, with integral hood guard design to prevent contamination from other users, airborne deposits and tampering.

**PUSHBUTTON ACTUATION MECHANISM**

Self-closing, vandal-resistant pushbutton does not require grasping or twisting.

**PANELS**

Backpanel constructed of stainless steel, No. 300 series with satin finish. Solid 14 gauge heavy duty stainless steel underplate and vandal resistant pinned torx screws. 1/4" thick heavy duty stainless steel mounting backplate on fountain arm.

**AUTOMATIC STREAM HEIGHT REGULATOR**

Self-closing assembly is located inside unit to prevent tampering and can be adjusted from front pushbutton. Unit resists corrosion and liming. A constant stream height is automatically maintained under line pressures that vary from 20 to 105 psi.

**INLET STRAINER**

Easily cleaned in-line strainer screen traps particles of 140 microns or larger before they enter the waterway.

**WATER INLET**

3/8" O.D. Tubing

**DRAIN OUTLET**

1-1/4" tube outlet for 1-1/4" slip joint connection.

**SUGGESTED SPECIFICATIONS**

Both fountains shall include pushbutton on the front. Both shall include contour-formed basins to eliminate splashing and standing water, and shall have rounded corners and edges. Each projector shall be chrome-plated vandal-resistant type with integral hood guard and anti-squirt feature. Fountain shall comply with ANSI 117:1 and ADA for visual and motion disabilities. The manufacturer shall certify the unit to meet the requirements of NSF/ANSI 61, and the Safe Drinking Water Act.

Note: Continued product improvement makes specifications subject to change without notice. See Halsey Taylor website for most current spec sheet.



**Standard Finish is Stainless Steel**

**Optional Accessories (extra cost)**

- Cane Touch Apron
- APHT Access Panels (2)
- Water Filter (2 recommended)

**Each HDFBLEBP consists of 1 carton as follows:**

Fountain, Panel and Misc. Parts

**Trap and service stop not included.**

**Shipping weight: 74 lbs.**

JOB NAME: \_\_\_\_\_  
 \_\_\_\_\_  
 \_\_\_\_\_  
 ENGINEER/CONTRACTOR NAME:  
 \_\_\_\_\_  
 APPROVAL: \_\_\_\_\_  
 DATE: \_\_\_\_\_



# HDFBLEBP

## Heavy Duty Contour™ Barrier-Free Bi-Level Fountain

(CONTINUED)

### MOUNTING INSTRUCTIONS

Refer to diagrams for rough-in of plumbing. Mount wall plate assembly to wall per the installation instructions. Hang fountain panel over the wall plate assembly. Attach fountains to wall plate assembly. Water service line and waste line are to be assembled as required. Final check for leaks and correct functions of fountain should be made. (For details see the installation instructions.)

**CAUTION** — Fountain must be securely bolted to wall.

### OPERATING PRESSURES:

Supply water - 105 psi maximum

Installation requires trap to be installed in wall. A service supply stop must be installed at the fountain inlet line. Trap and service stop not included.

NOTE: For wall support required locations see installation instructions provided with panel and fountains.

### FRONT VIEW

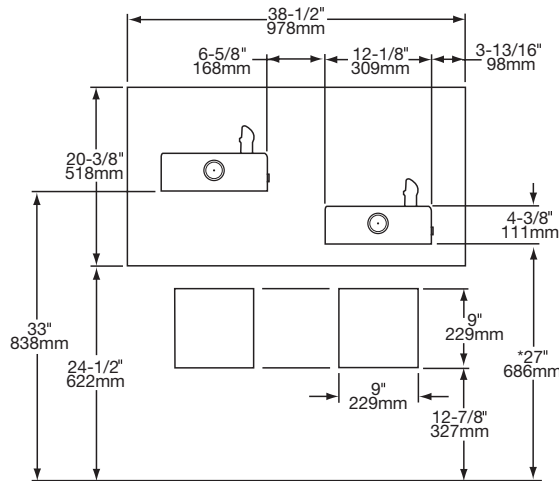

### SIDE VIEW

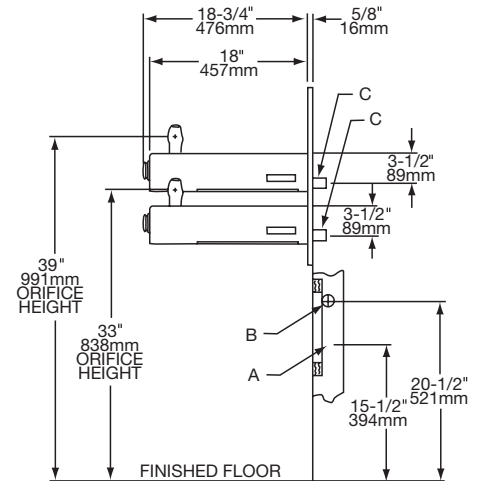

\*24" (610mm) for child ADA.

### WALL LAYOUT

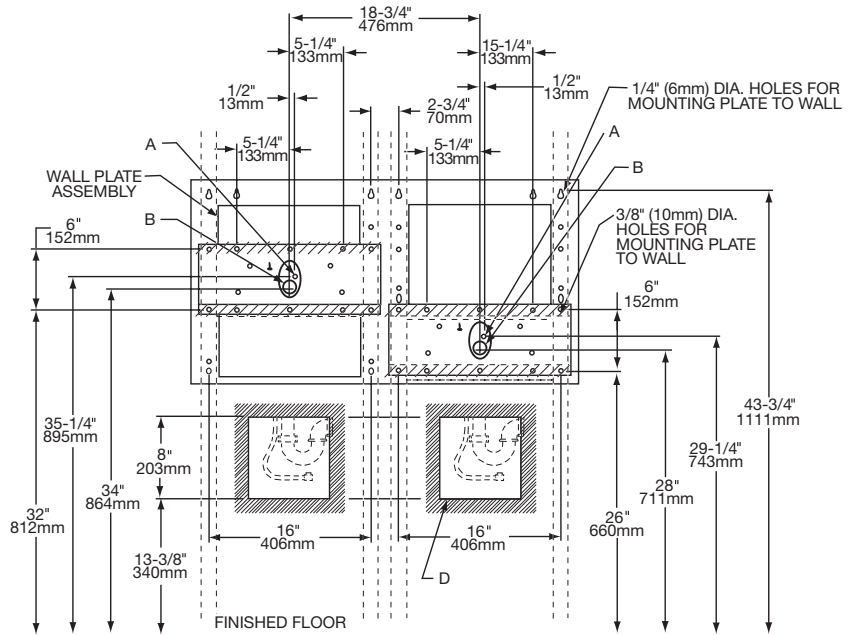

### LEGEND:

- A = RECOMMENDED WATER SUPPLY LOCATION 3/8" O.D. UNPLATED COPPER TUBE CONNECT STUBBED 1-1/2" (38mm) FROM WALL SHUT OFF BY OTHERS
- B = RECOMMENDED LOCATION FOR WASTE OUTLET 1-1/4" O.D. DRAIN
- C = 1-1/4" DRAIN FURNISHED
- D = OPENING FOR OPTIONAL APHT ACCESS PANEL

NOTE: REINFORCE THE WALL IN THE SHADED AREAS