

# ELKAY®

## SPECIFICATIONS

### Air Cooled Refrigerated Water Cooler with WaterSentry® VII Filter System Fully Recessed Models LJNEM8 and LJNEM12

#### GENERAL

Wall type, fully recessed electric refrigerated water cooler with stainless steel louvered ventilating grill.

Unit furnished with hermetically sealed tube-tank cooling unit in undersection. Cooling unit removable without disturbing electrical or drain connections. Condenser, air cooled by fan. Plumbing and electrical connections are concealed. Entire unit does not extend more than 1/2" from wall surface. Flexi-Guard® safety bubbler. Control push button located on front panel below stream projector. Flow regulator provides constant stream from 20 to 105 psi water pressure.

**THIS WATER COOLER COMPLIES WITH THE REQUIREMENTS OF A.D.A. (AMERICANS WITH DISABILITIES ACT) PROVIDING THE FLOOR TO ORIFICE HEIGHT IS 36" OR LESS AND PROPER CLEAR FLOOR SPACE IS PROVIDED.**

#### NO LEAD DESIGN

**THIS WATER COOLER COMPLIES WITH THE LEAD-FREE DEFINITION IN THE SAFE DRINKING WATER ACT OF 1986 AND LEAD CONTAMINATION CONTROL ACT OF 1988.**

#### WATERSENTRY® VII FILTER SYSTEM

Elkay Water Coolers are equipped with the WaterSentry VII Filter System. Tested to ANSI/NSF Standard 53 yields a reduction of soluble and in-soluble lead content to less than 0.015mg/l. This translates to lead reduction levels of 93% to 99%. Class 1 particulate reduction as tested per ANSI/NSF 42. Removes over 97.5% of free available chlorine which provides Class 1 performance as tested to ANSI/NSF 42. Provides taste and odor improvement.

#### CAPACITIES CHART

Model Number	Base Rate	**GPH of 50°F Drinking Water			Rated Watts	Full Load Amps	Compr. HP	Glass Filler Option	*Pre-Cooler	Ship. Wt. Lbs.
		Room Temperature °F								
		70°F	80°F	90°F						
LJNEM8	7.8	9.0	8.4	7.8	380	4.7	1/5	Yes	No	107
LJNEM12	7.8	15.7	13.8	12.0	380	4.7	—	Yes	Yes	129

\*\*Based on 80°F inlet water temperature. \*Pre-cooler capacities based on 60% spill through pre-cooler. †Glass filler available at extra cost. Requires factory preparation to receive glass filler. Glass filler LK109a can be furnished. Rated watts shown are based on operational (run) time, in accordance with A.R.I. Standard 1010 conditions. Specific applications will determine the actual watts consumed per hour. Watts consumed will be based on number of people served per hour (usage), ambient temperatures, and inlet water temperature.

#### COOLING SYSTEM

**Motor Compressor:** Hermetically sealed, reciprocating type, 115V, 60 Hz single phase. Lubricated for life.

**Condenser:** Fan cooled. Fan motor is permanently lubricated.

**Cooling Unit:** Combination tube-tank type. Tube portion is continuous coil of copper tubing. Fully insulated with EPS foam which meets Underwriters Laboratories Inc. requirements for self extinguishing plastic material.

**Refrigerant Control:** Refrigerant type HFC-134a is controlled by accurately calibrated capillary tube for positively trouble-free performance.

**Temperature Control:** Enclosed adjustable thermostat is easily accessible by removing front grill panel.

#### CONSTRUCTION

**Fountain Top:** One piece #16 gauge stainless steel, type 304. Anti-splash design has Exclusive Cascade basin, tested most splash-resistant. Fountain has 1-3/4" covered corners. Exposed surfaces polished to a uniform Elkay luster finish.

**Stream Projector:** Control push button operated, with an in-line flow regulator from 20 psi to 105 psi. Stream projector with protective hood meets all sanitary codes.

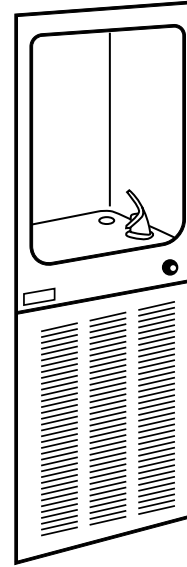

Model LJNEM8

**Exclusive Flexi-Guard® Safety Bubbler:** Innovative design utilizes a pliable polyester elastomer to prevent accidental mouth injuries. Flexes on impact, then returns to original position. Strong. Abrasion-resistant. Anti-sweat. Meets UL requirements and all sanitary codes. Keyed in location to prevent rotation.

**Front Panel Grill:** Made of type 304, stainless steel, polished to a uniform Elkay finish. Removable louvered ventilating grill encloses refrigeration unit and plumbing.

**Wall Mounting Box:** MB23AL mounting box furnished with each unit. Box allows flush mounting to finished wall, plumbing and electrical service holes are pre-punched on both right and left side to facilitate installation.

**Protected by Elkay's 5 Year Limited Warranty** on the refrigeration system of the unit.

Elkay Pressure-Type Water Coolers are designed to operate on 20 psi to 105 psi supply line pressure. If inlet pressure is above 105 psi, a pressure regulator must be installed in the supply line. Any damage caused by reason of connecting this product to supply line pressures lower than 20 psi or higher than 105 psi is not covered by the warranty.

#### STANDARDS

 Elkay Electric Air Cooled Water Coolers are listed by Underwriters Laboratories Inc. and comply with both Canadian and U.S. requirements.

These units comply with A.R.I. Standard 1010.

This cooler is certified by WQA to lead-free compliance including NSF/ANSI 61-ANNEX G, AB 1953.

In keeping with our policy of continuing product improvement, Elkay reserves the right to change product specifications without notice. Please visit [elkayusa.com](http://elkayusa.com) for most current version of Elkay product specification sheets.

This specification describes an Elkay product with design, quality and functional benefits to the user. When making a comparison of other producers' offerings, be certain these features are not overlooked.

**Air Cooled Refrigerated Water Cooler  
with WaterSentry® VII Filter System  
Fully Recessed  
Models LJNEM8 and LJNEM12**

**ELKAY®  
ROUGH-IN DIMENSIONS**

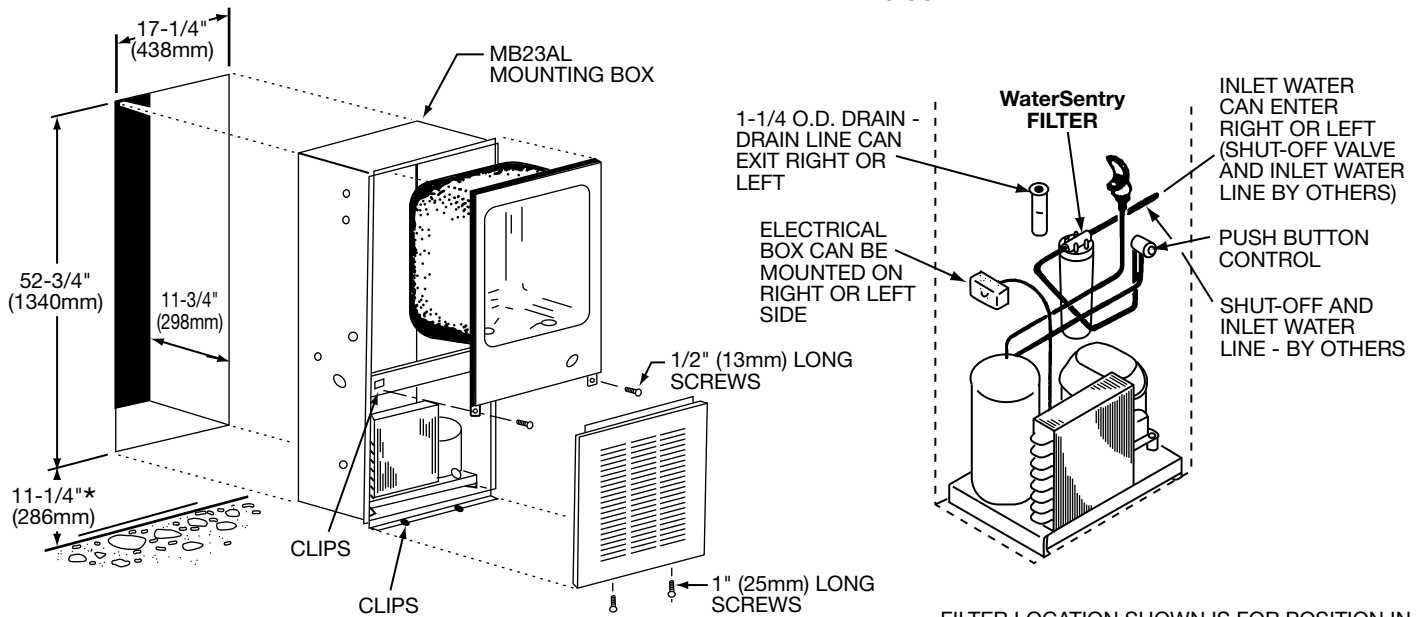
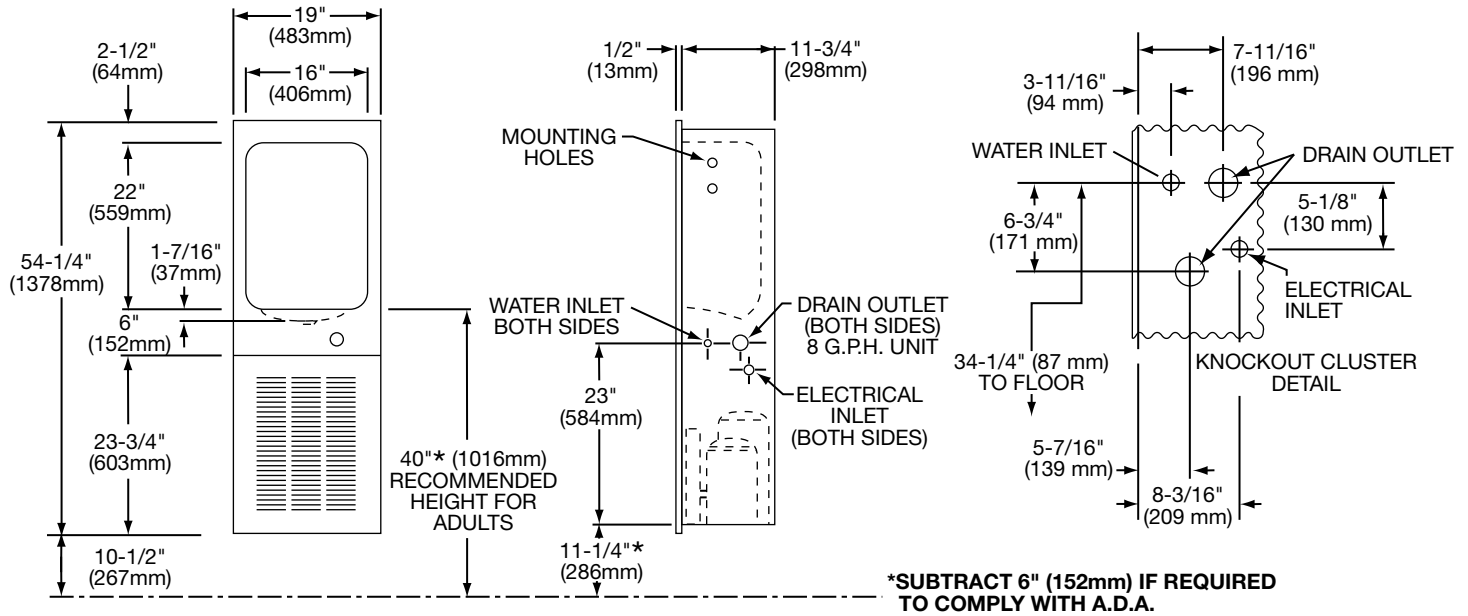

**IMPORTANT!  
INSTALLER PLEASE NOTE:**

This water cooler has been designed and built to provide water to the user which has not been altered by materials in the cooler waterways.

The grounding of electrical equipment such as telephone, computers, etc., to water lines is a common procedure. This grounding may be in the building but may also occur away from the building. This grounding can cause electrical feedback into a water cooler creating an electrolysis which creates a metallic taste or causes an increase in the metal content of the water. This condition is avoidable by installing the cooler using the proper materials as shown below.

**NOTICE**

This water cooler must be connected to the water supply using a dielectric coupling. The cooler is furnished with a non-metallic strainer which meets this requirement.

The drain trap which is provided by the installer should also be plastic to completely isolate the cooler from the building plumbing system.

FILTER LOCATION SHOWN IS FOR POSITION IN WATER LINE CIRCUIT ONLY. ACTUAL POSITION WILL BE WHERE MOUNTING BRACKET IS FASTENED IN MOUNTING BOX.