



Pedestal Fountain

MODEL 4715



This fountain is certified to NSF/ANSI 61.

GENERAL

Pedestal, Endura™ steel fountain with textured powder coat finish and E-Coat immersion for year-round beauty with minimum maintenance. The E-Coat immersion process coats the outside and inside of the fountain for the ultimate in corrosion protection. Contour-formed stainless steel basin with rounded corners and edges reduces splatter, insures proper drainage and prevents standing waste water.

BUBBLER

Exclusive one-piece, vandal-resistant, chrome-plated two-stream mound-building bubbler with non-removable anti-squirt feature and integral hood insures a satisfying drink of water.

PUSHBUTTON ACTUATION MECHANISM

Self closing, vandal-resistant pushbutton does not require grasping or twisting.

AUTOMATIC STREAM HEIGHT REGULATOR

Self-closing assembly is located inside unit to prevent tampering. Unit resists corrosion and liming. A constant stream height is automatically maintained under line pressures that vary from 20 to 105 psi.

INLET STRAINER

Easily cleaned in-line strainer screen traps particles of 140 microns or larger before they enter the waterway.

WATER INLET

3/8" O.D. Tubing

DRAIN OUTLET

1-1/4" tube outlet for 1-1/4" slip joint connection.

ACCESS PANEL

Manufactured of heavy-gauge steel with vandal-resistant screws. Provides access for easy hook-up of all plumbing connections.

SUGGESTED SPECIFICATIONS

Fountain shall be upright pedestal, Endura™ Steel with powder coat epoxy finish. Shall include pushbutton on the front. Shall include stainless steel contour-formed basin to eliminate splashing and standing water, and shall have rounded corners and edges. Projector shall be two-stream, mound-building type with integral hood guard and anti-squirt feature. The manufacturer shall certify the unit to meet the requirements of NSF/ANSI 61, and the Safe Drinking Water Act.

Note: Continued product improvement makes specifications subject to change without notice. See Halsey Taylor website for most current spec sheet.



Standard finish is Evergreen textured powder-coat Endura II™

Each 4715 consists of 1 carton of the following:

Fountain

Trap and service stop not included.

Shipping weight: 62 lbs.

JOB NAME: _____

ENGINEER/CONTRACTOR NAME: _____

APPROVAL: _____

DATE: _____



4715

Endura™ Steel Pedestal Fountain

(CONTINUED)

MOUNTING INSTRUCTIONS and PLUMBING CONNECTIONS

Provide solid, well-drained surface to mount pedestal fountain (concrete pad recommended.) (4) 3/8" anchor bolts (not included) should be attached securely to mounting surface in order to secure fountain. (Refer to rough-in diagram.)

Locate and install plumbing through ground as required. NOTE: Fountain is not furnished with service valve.

Position pedestal over plumbing and secure base to anchor bolts. Remove access panels and connect supply and water lines. Turn on water supply and check for leaks. Reassemble access panels to pedestal.

Trap and service stop not included.

OPERATING PRESSURES

Supply water - 20 psi minimum to 105 psi maximum.

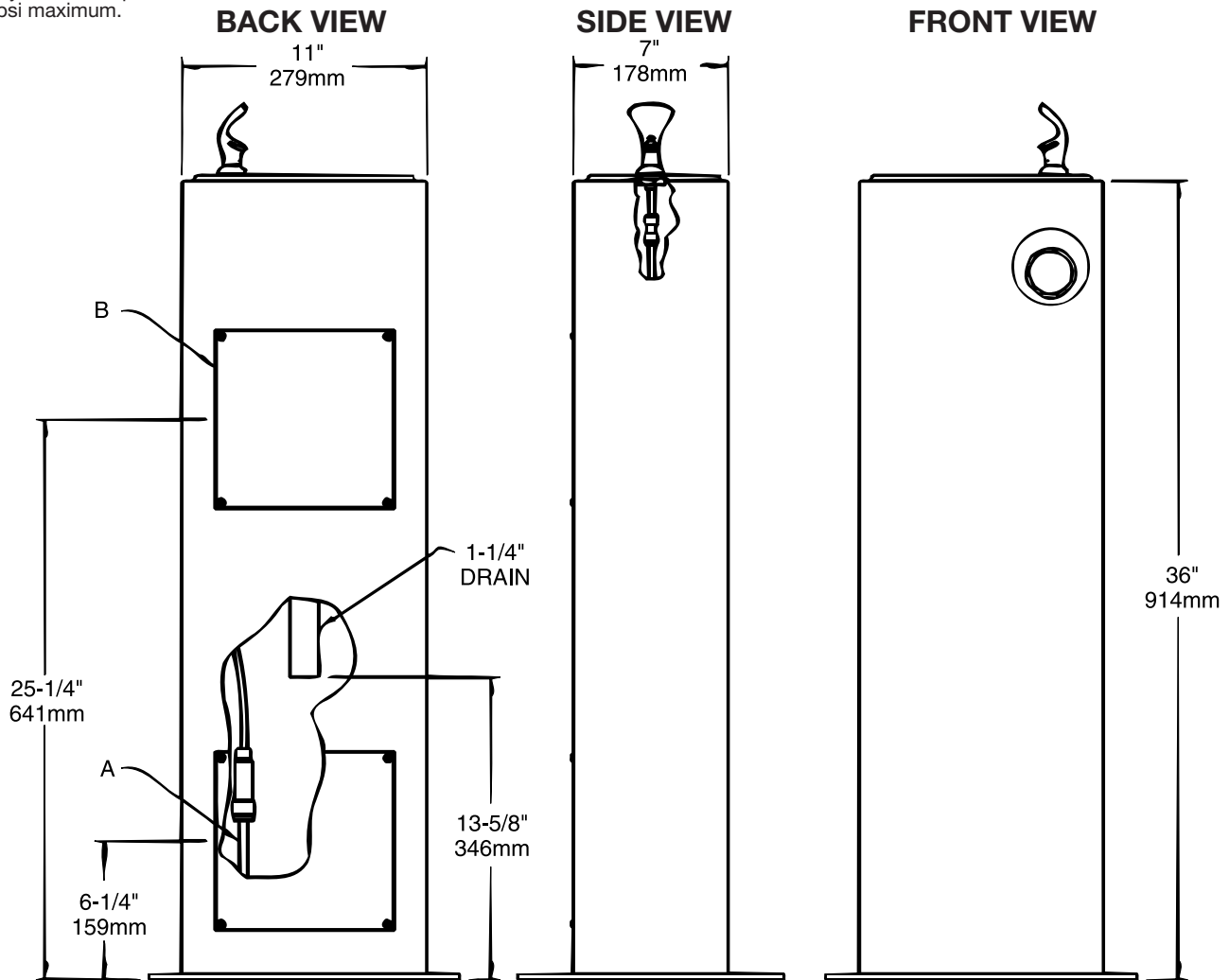
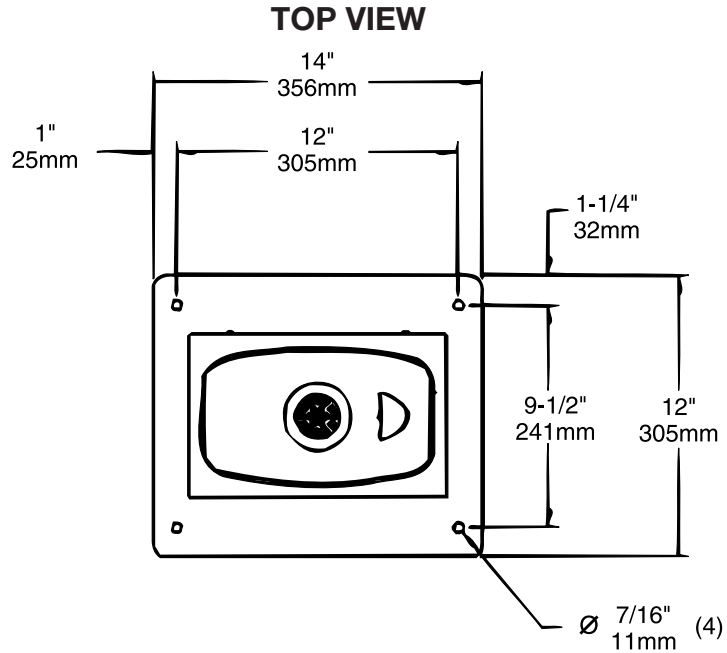

LEGEND:

A = 3/8" O.D. UNPLATED COPPER TUBE CONNECT - SHUT OFF VALVE BY OTHERS
 B = ACCESS PANEL

Halsey Taylor®