



# Freeze-Resistant Endura II™ Tubular Pedestal Fountain

## MODEL 4400 FR



This fountain is certified to NSF/ANSI 61.

### GENERAL

Pedestal, Endura II™ Steel fountain with textured powder coat finish and E-Coat immersion for year-round beauty with minimum maintenance. The E-Coat immersion process coats the outside and inside of the fountain for the ultimate in corrosion protection. Contour-formed stainless steel basin with rounded corners and edges reduces splatter, insures proper drainage and prevents standing waste water. Ideally suited for installation in public areas.

### FREEZE-RESISTANT VALVE SYSTEM

Freeze-resistant valve designed for ground installation 18" below the frost line. 60" of access tubing provided with the freeze-resistant valve system. The length of the tubing can be adjusted in the field for lesser frost depths.

### BUBBLER

Vandal-resistant bubbler is one-piece, chrome-plated, with integral hood guard design to prevent contamination from other users, airborne deposits and tampering.

### PUSHBUTTON ACTUATION MECHANISM

Self closing, vandal-resistant pushbutton does not require grasping or twisting.

### AUTOMATIC STREAM HEIGHT REGULATOR

Self-closing assembly is located inside unit to prevent tampering. Unit resists corrosion and liming. A constant stream height is automatically maintained under line pressures that vary from 20 to 105 psi.

### WATER INLET

3/8" female NPT fitting

### DRAIN OUTLET

Drain requirements are detailed in the owner's manual.

### ACCESS PANEL

Manufactured of heavy-gauge steel with vandal-resistant screws. Provides access for easy hook-up of all plumbing connections.

### SUGGESTED SPECIFICATIONS

Fountain shall include pushbutton on the front. Shall include contour-formed basin to eliminate splashing and standing water, and shall have rounded corners and edges. Projector shall be chrome-plated vandal-resistant type with integral hood guard and anti-squirt feature. The manufacturer shall certify the unit to meet the requirements of NSF/ANSI 61, and the Safe Drinking Water Act.

Note: Continued product improvement makes specifications subject to change without notice. See Halsey Taylor website for most current spec sheet.



Standard finish is Evergreen textured powder-coat Endura II™

Each 4400 FR consists of 2 cartons of the following:

- Fountain
- Freeze-Resistant Valve System

Service stop not included.

Shipping weight: 143 lbs.

JOB NAME: _____
_____
ENGINEER/CONTRACTOR NAME: _____
_____
APPROVAL: _____
DATE: _____



# 4400 FR

## Endura II™ Tubular Pedestal Fountain

(CONTINUED)

### MOUNTING INSTRUCTIONS and PLUMBING CONNECTIONS

Site and drainage excavation is required for fountain installation. Refer to owner's manual for site preparation details. Provide solid, well-drained surface to mount pedestal fountain (concrete pad recommended). (6) 1/2" anchor bolts (not included) should be attached firmly to mounting surface in order to secure fountain. Refer to rough-in diagram and be sure to allow an opening for the freeze-resistant valve in the ground as shown in the installation instructions that accompany the fountain. Refer to local codes for any additional requirements.

NOTE: Fountain is not furnished with service valve. Assemble fountain to prepared site and mounting pad.

Position pedestal over plumbing and secure base to anchor bolts. Remove access panels and connect supply and water lines. Turn on water supply and check for leaks. Refer to owner's manual for detailed instructions.

### OPERATING PRESSURES:

Supply water - 105 psi maximum

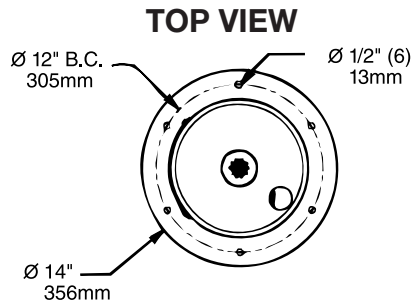

### FRONT VIEW

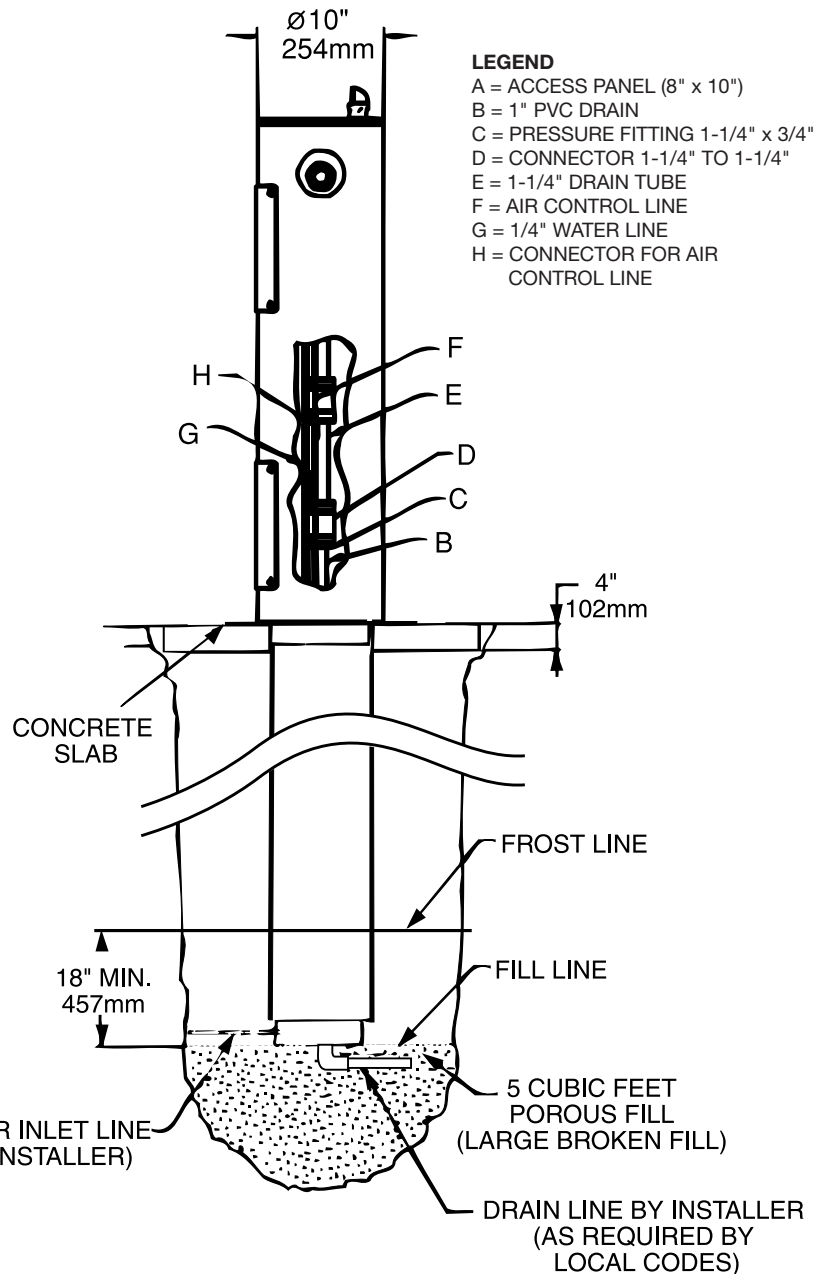

### LEGEND

- A = ACCESS PANEL (8" x 10")
- B = 1" PVC DRAIN
- C = PRESSURE FITTING 1-1/4" x 3/4"
- D = CONNECTOR 1-1/4" TO 1-1/4"
- E = 1-1/4" DRAIN TUBE
- F = AIR CONTROL LINE
- G = 1/4" WATER LINE
- H = CONNECTOR FOR AIR CONTROL LINE

### BACK VIEW

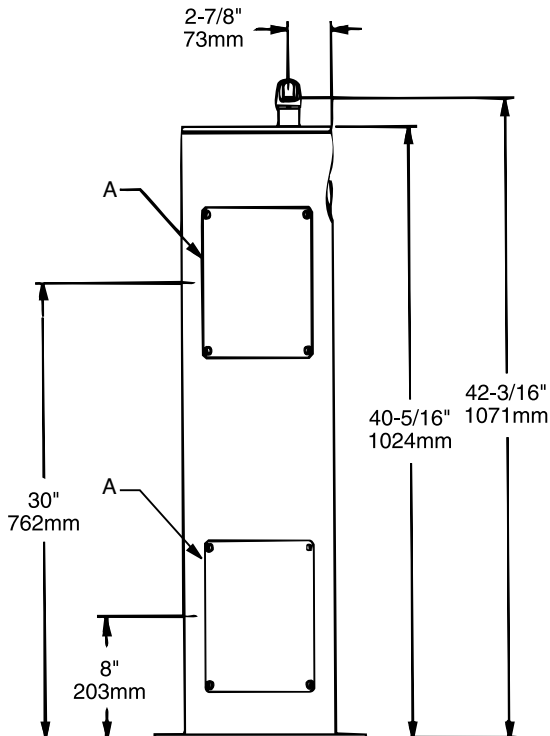

**Halsey Taylor®**