



**MODEL 4420 FR**

**Barrier-Free Fountain**



This fountain is certified to NSF/ANSI 61.

**GENERAL**

Pedestal, Endura II™ Steel fountain with textured powder-coat finish and E-coat immersion for year-round beauty with minimum maintenance. The E-coat immersion process coats the outside and inside of the fountain for the ultimate in corrosion protection. Contour-formed stainless steel bi-level basins with rounded corners and edges reduce splatter, insure proper drainage and prevent standing waste water. Designed to be easily accessible to both physically challenged and able-bodied individuals. Ideally suited for installation in public areas. Model meets state and federal requirements as defined by the Americans with Disabilities Act.

**FREEZE-RESISTANT VALVE SYSTEM**

Freeze-resistant valve designed for ground installation 18" below the frost line. 60" of access tubing provided with the freeze-resistant valve system. The length of the tubing can be adjusted in the field for lesser frost depths.

**BUBBLER**

Vandal-resistant bubbler is one-piece, chrome-plated. Unit has integral hood guard design to prevent contamination from other users, airborne deposits and tampering.

**PUSHBUTTON ACTUATION MECHANISM**

Self closing, vandal-resistant pushbutton does not require grasping or twisting.

**AUTOMATIC STREAM HEIGHT REGULATOR**

Self-closing assembly is located inside unit to prevent tampering. Unit resists corrosion and liming. A constant stream height is automatically maintained under line pressures that vary from 20 to 105 psi.

**WATER INLET**

3/8" female NPT fitting.

**DRAIN OUTLET**

Drain requirements are detailed in the owner's manual.

**ACCESS PANEL**

Manufactured of heavy-gauge steel with vandal-resistant screws. Provides access for easy hook-up of all plumbing connections.

**SUGGESTED SPECIFICATIONS**

Fountain shall include pushbuttons on the front and side. Shall include contour-formed basins to eliminate splashing and standing water, and shall have rounded corners and edges. Projectors shall be chrome-plated vandal-resistant type with integral hood guard and anti-squirt feature. Fountain shall comply with ANSI 117:1 and ADA for visual and motion disabilities. The manufacturer shall certify the unit to meet the requirements of NSF/ANSI 61, and the Safe Drinking Water Act.

Note: Continued product improvement makes specifications subject to change without notice. See Halsey Taylor website for most current spec sheet.



Standard Finish is Evergreen textured powder-coat Endura II™

Each 4420 FR consists of 2 cartons of the following:

- Fountain
- Freeze-Resistant Valve System

Service stop not included.

Shipping weight: 175 lbs.

JOB NAME: \_\_\_\_\_  
 \_\_\_\_\_  
 \_\_\_\_\_  
 ENGINEER/CONTRACTOR NAME:  
 \_\_\_\_\_  
 APPROVAL: \_\_\_\_\_  
 DATE: \_\_\_\_\_



# 4420 FR

## Freeze-Resistant Barrier-Free Endura II™ Tubular Pedestal Fountain with Twin Receptors

(CONTINUED)

### MOUNTING INSTRUCTIONS and PLUMBING CONNECTIONS

Site and drainage excavation is required for fountain installation. Provide solid, well-drained site and drainage surface to mount pedestal fountain (concrete pad recommended.) (6) 1/2" anchor bolts (not included) should be attached firmly to mounting surface in order to secure fountain. Refer to rough-in diagram and be sure to allow an opening for the freeze-resistant valve in the ground as shown in the installation instructions that accompany the fountain. Refer to local codes for any additional requirements.

NOTE: Fountain is not furnished with service valve. Assemble fountain to prepared site and mounting pad.

Position pedestal over plumbing and secure base to anchor bolts. Remove access panels and connect supply and water lines. Turn on water supply and check for leaks. Refer to owner's manual for detailed instructions.

### OPERATING PRESSURES:

Supply water - 105 psi maximum

### TOP VIEW

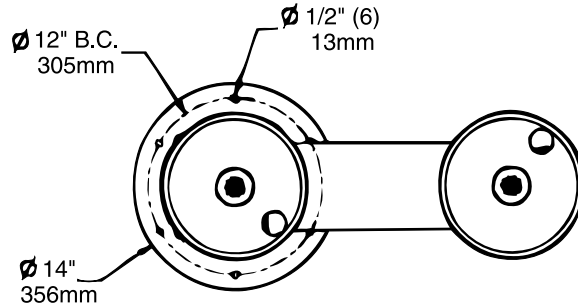

### SIDE VIEW

#### LEGEND

- A = ACCESS PANEL (8" x 10")
- B = REMOVABLE BOTTOM COVER
- C = 1" PVC DRAIN
- D = PRESSURE FITTING 1-1/4" x 3/4"
- E = CONNECTOR 1-1/4" TO 1-1/4"
- F = 1-1/4" DRAIN TUBE
- G = AIR CONTROL LINE
- H = 1/4" WATER LINE
- J = CONNECTOR FOR AIR CONTROL LINE

\*ADA Requirement

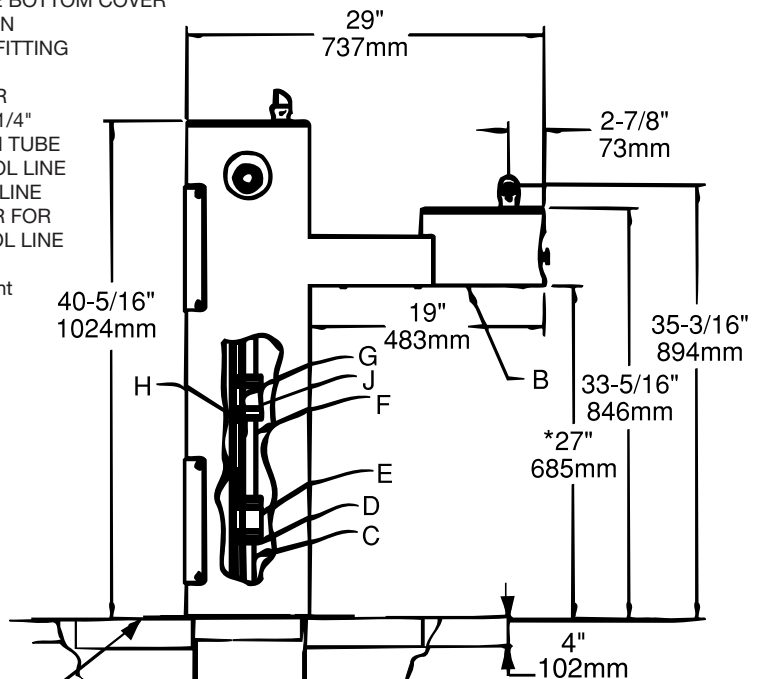

CONCRETE SLAB

FROST LINE

FILL LINE

5 CUBIC FEET POROUS FILL (LARGE BROKEN FILL)

DRAIN LINE BY INSTALLER (AS REQUIRED BY LOCAL CODES)

### BACK VIEW

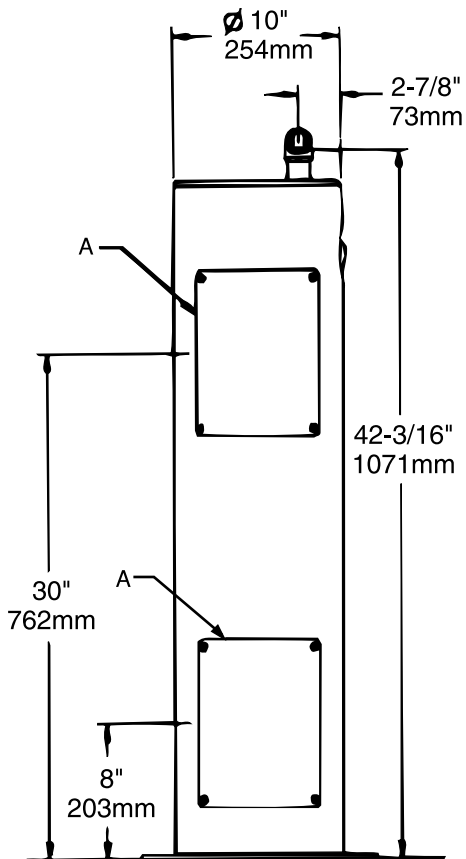

**Halsey Taylor**®