

EBFATL8*1A, LIEATL8*1A

With FLEXI-GUARD®

Installation/Care/Use Manual

USES HFC-134A REFRIGERANT

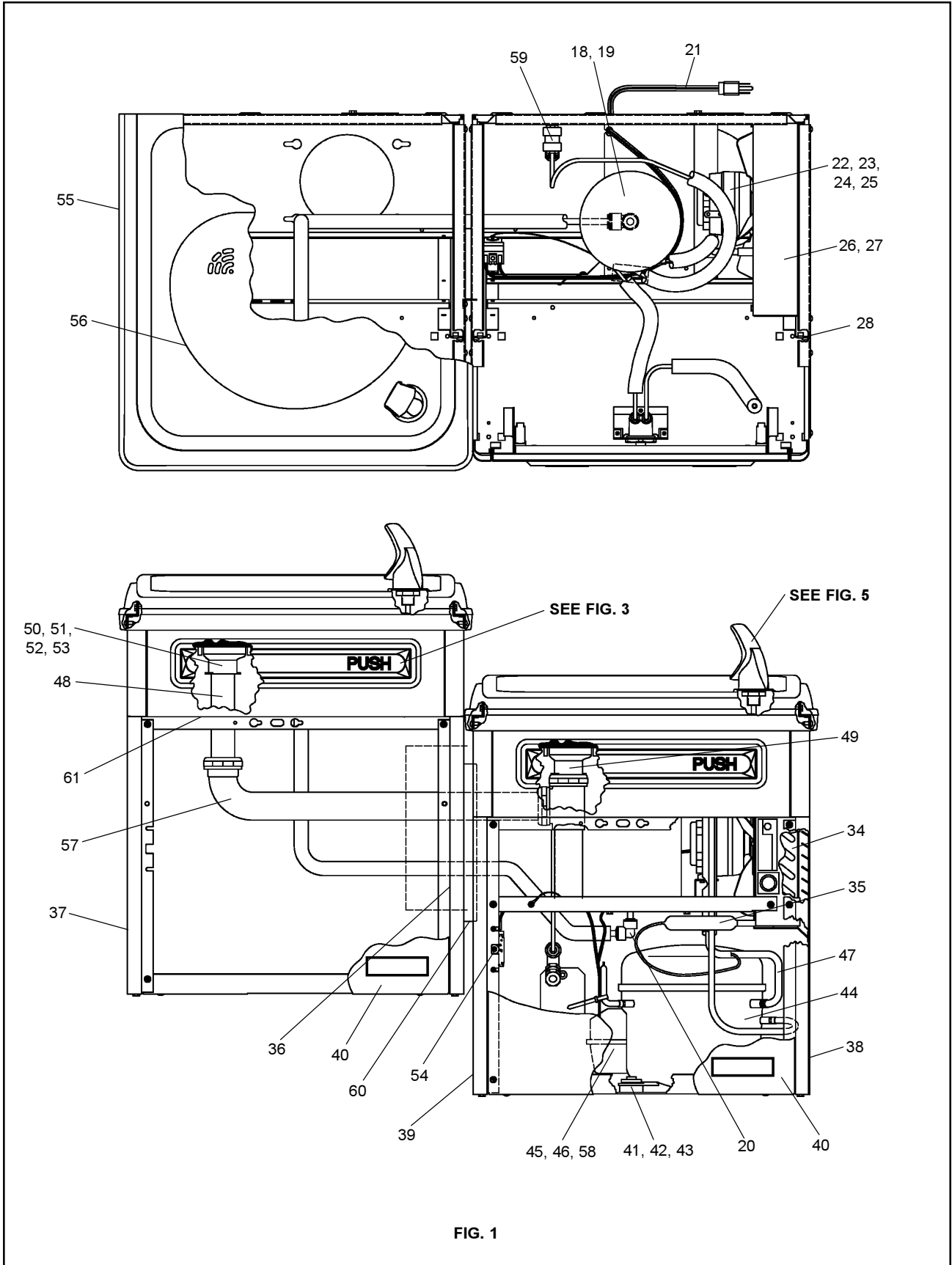

FIG. 1

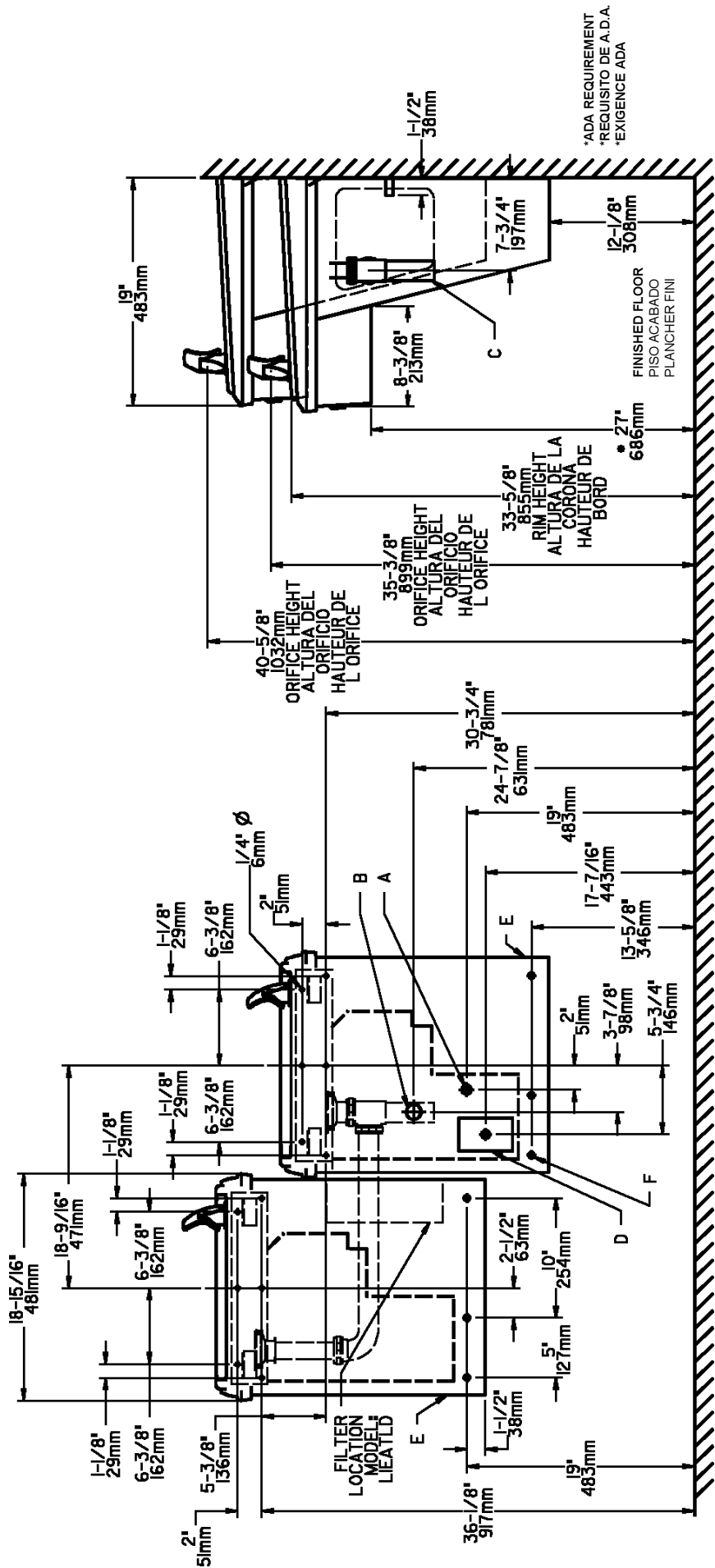

FIG. 2

LEGENDILEYENDAILÉGENDE

- A = RECOMMENDED WATER SUPPLY LOCATION 3/8 O.D. TUBE CONNECT STUB 1-1/2 IN. (38mm) OUT FROM WALL SHUT OFF BY OTHERS
UBICACIÓN RECOMENDADA PARA LA SECCIÓN DE TUBO DE 3/8" DE DIÁMETRO DE SUMINISTRO DE AGUA RESALTADO OFF BY OTHERS
- B = RECOMMENDED LOCATION FOR WASTE OUTLET 1-1/2" O.D. DRAIN
EMPLACEMENT RECOMMANDÉ POUR L'ALIMENTATION EN EAU. TIGE DE PO/S 3/8" - SORTI DU MUR 1-1/2" (38mm)
- C = 1-1/2" TRAP NOT FURNISHED
UBICACIÓN RECOMENDADA PARA EL DRENAJE DE SALIDA DE AGUA. DE 1-1/2" DE DIÁMETRO.
- D = ELECTRICAL SUPPLY (3) WIRE RECESSED BOX
CAJA RECESIVA DE ALAMBRES (3) DE SUMINISTRO ELÉCTRICO
- E = INSURE PROPER VENTILATION BY MAINTAINING 6" (152mm) (MIN.) CLEARANCE FROM CABINET LOUVERS TO WALL.
BOITE ENCASTRÉE D'ALIMENTATION ÉLECTRIQUE (3) FILS
- F = 7/16 BOLT HOLES FOR FASTENING UNIT TO WALL.
ASEGURE UNA VENTILACIÓN ADECUADA MANTENIENDO UN ESPACIO 6" (152mm) (MIN.) DE HOLGURA ENTRE LA REJILLA DE VENTILACIÓN DEL MUEBLE Y LA PARED
ASSUREZ-VOUS UNE BONNE VENTILATION EN GARDANT 6" (152mm) (MIN.) ENTRE LES ÉVÉNENTS DE L'ENCEINTE ET LE MUR.
AGUJEROS DE LAS TUERCAS DE 7/16 PARA SUJETAR LA UNIDAD A LA PARED
TROUS D'ÉCROUS 7/16 POUR FIXER L' APPAREIL AU MUR

PUSHBAR MECHANISM

WATER VALVE MECHANISM - ADJUSTMENT PROCEDURE:

- Turn adjustment screw (Item 16) "Counter-Clockwise" until water flow from bubbler starts.
- Turn adjustment screw "Clockwise" until water flow stops, **THEN** turn an additional 1/2 turn.

NOTE: Adjustments stated above are viewed from underneath unit (bottom side of dispenser panel Item 1).

NOTE: If continuous flow occurs at the end of the compressor cycle, turn cold control (Item 54) counter-clockwise 1/4 turn.

LEGEND - A: NOTE: Water flow direction.

B: Adjust this screw to eliminate mechanism "Free Play" or continuous flow from bubbler conditions (SEE ADJUSTMENT PROCEDURE).

C: Stream height adjustment (SEE NOTE 8).

FIG. 3

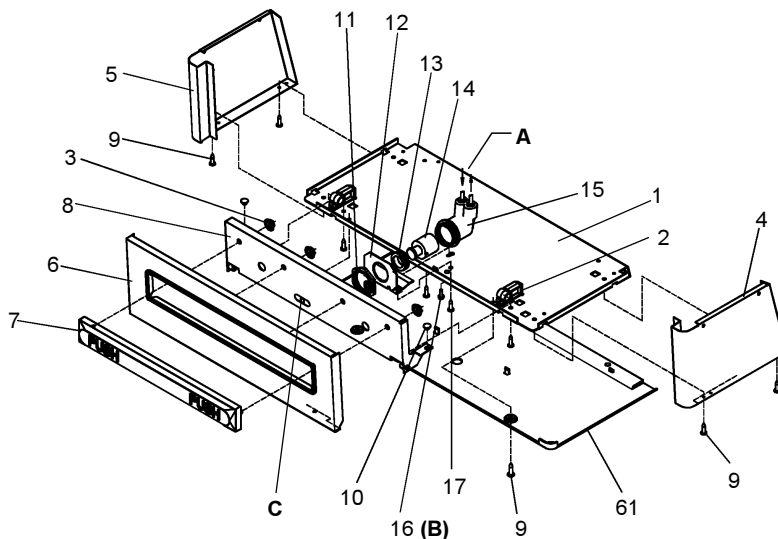

HANGER BRACKETS & TRAP INSTALLATION

- 1) Remove hanger bracket fastened to back of cooler by removing one (1) screw.
- 2) Mount the hanger bracket and trap as shown in Figure 2. **NOTE:** Hanger Bracket **MUST** be supported securely. Add fixture support carrier if wall will not provide adequate support.

IMPORTANT:

- 7-3/4 in. (197mm) dimension from wall to centerline of trap must be maintained for proper fit.
- Anchor hanger securely to wall using all six (6) 1/4 in. dia. mounting holes.

- 3) Install straight valve for 3/8" O.D. tube.

INSTALLATION OF COOLER

- 4) Hang the cooler on the hanger bracket. Be certain the hanger bracket is engaged properly in the slots on the cooler back as shown in Figure 2.
- 5) Loosen the two (2) screws holding the lower front panel at the bottom of cooler base and two (2) screws at the top. Remove the front panel and set aside.
- 6) Connect water inlet line--See Note 4 of General Instructions.
- 7) Remove the slip nut and gasket from the trap and install them on the cooler waste line making sure that the end of the waste line fits into the trap. Assemble the slip nut and gasket to the trap and tighten securely.

START UP

Also See General Instructions

- 8) Stream height is factory set at 35 PSI. If supply pressure varies greatly from this, adjust screw, accessible by removing front panel (Item 6, Fig. 3). CW adjustment will raise stream and CCW adjustment will lower stream. For best adjustment, stream should hit basin approximately 6-1/2" (165mm) from bubbler.
- 9) Replace the front panel and secure by retightening four (4) screws.

ITEM NO.	PART NO.	DESCRIPTION
1	22897C	Panel-Bottom Dispenser
2	51531C	Block-Pivot
3	111411743620	Nut-1/4", Self Threading
4	See Color Table	Panel-Right Side
5	See Color Table	Panel-Left Side
6	See Color Table	Panel-Front
7	51559C	Insert-Pushbar, Gray
	51560C	Insert-Pushbar, Brown
8	22900C	Bracket-Front Push
9	70864C	Screw-#8 x 5/8" Lg. Torx/Slot
10	51667C	Bumper-Pressbar
11	40045C	Hex Nut
12	23003C	Bracket-Regulator Mounting
13	15005C	Retaining Nut
14	61314C	Regulator
15	50986C	Holder-Regulator
16	70935C	Screw-Shoulder x 1/2" Lg.
17	112627543890	Screw-Regulator Mtg. Brkt.

COLOR TABLE

PANEL COLOR	Item No. 4 Part No.	Item No. 5 Part No.	Item No. 6 Part No.
Bronzestone	23014C	23007C	22931C
Gray Beige	23015C	23008C	22932C
Almond	23016C	23009C	22933C
Stainless Stl	22822C	22814C	22934C
Sandalwood	23017C	23010C	22935C
Granite	23020C	23013C	27211C

PARTS LIST 115V

ITEM NO.	PART NO.	DESCRIPTION
18	62220C	Evaporator Assembly
19	70767C	Clip - Evap. Retaining
20	70836C	Elbow
21	31517C	Power Cord
22	30699C	Fan Blade (Use w/ Items 44 & 44a)
	30664C	Fan Blade (Use w/ Item 44b)
23	70018C	Hex Nut - Fan Blade
24	31490C	Fan Motor 115V (Use w/ Items 44 & 44a)
	31491C	Fan Motor 115V (Use w/ Item 44b)
25	111411443890	Screw - Fan Motor
26	22899C	Shroud - Fan
27	38417001	Screw - #8-18 x 3/8" Lg. (Fan Shroud)
28	75524C	Clip (Front and Rear Panels)
29	51349C	Bubbler Assembly
	51350C	Bubbler Assembly - Bronzestone
30	40322C	Orifice Assembly
	40066C	Orifice Assembly - Bronzestone
31	50934C	Guard
32	50168C	Pedestal
	50373C	Pedestal - Bronzestone
33	70012C	Locknut
34	62152C	Condenser
35	66202C	Drier
36	See Color Table	Panel - Right Rear (Left Unit)
37	See Color Table	Panel - Left Rear (Left Unit)
38	See Color Table	Panel - Right Rear (Right Unit)
39	See Color Table	Panel - Left Rear (Right Unit)
40	See Color Table	Panel - Front Lower
41	101516143550	Stud - Compressor Mtg.
42	100806740570	Grommet - Compressor Mtg.
43	19037000	Clip - Compressor Mtg.
44*	35767C	Compressor Serv. Pak FF7.5HBK
44a*	35761C	Compressor Serv. Pak FF6HBK
44b*	35807C	Compressor Serv. Pak AE3425Y
45	31025C	Overload/Relay 1.350.358 (Use w/ Item 44)
	31026C	Overload/Relay 1.350.356 (Use w/ Item 44a)
	35801C	Relay 9660-042-166 (Use w/ Item 44b)
46	35795C	Overload MRP26ALL-69 (Use w/ Item 44b)
	35766C	Cover - Relay (Use w/ Items 44 & 44a)
	30181C	Cover - Terminal (Use w/ Item 44b)
	30180C	Overload Spring (Use w/ Item 44b)
	30182C	Bale Strap (Use w/ Item 44b)
47	66214C	Heat Exchanger (Use w/ Items 44 & 44b)
	66215C	Heat Exchanger (Use w/ Item 44a)
48	45332C	Drain Tube (Left Unit)
49	45331C	Drain Tube (Right Unit)
50	50400C	Gasket - Drain
51	50401C	Ring Support - Drain
52	70444C	Clamp - Drain Gasket
53	70016C	Hex Nut #10-32
54	31513C	Cold Control
55	See Color Table	Adaptor - Basin
56	21903C	Basin
	21905C	Basin - Bronzestone
57	40022C	Tube - Drain Assembly
58	194243901550	Cover - Electrical Shield
59	70788C	Y-Strainer
60	See Color Table	Drain Trim Strip
61	See Color Table	Cover-Dispenser Bottom
NS	400660943730	Hanger Bracket

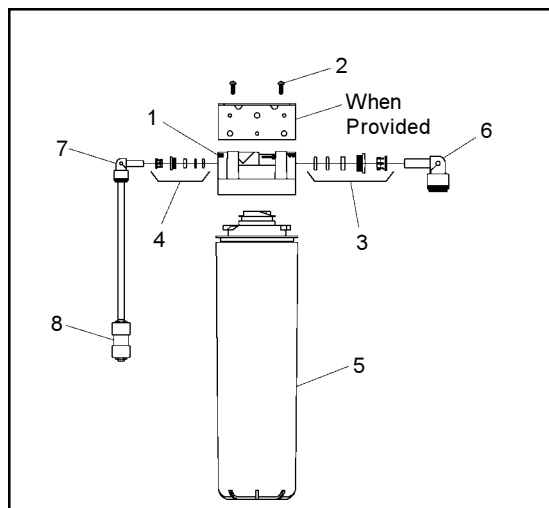

DESIGN 2000® FILTER PARTS LIST

ITEM NO.	PART NO.	DESCRIPTION
1	51294C	Filter Head Assy
2	70792C	Screw-#8-18 x .75" PH
3	70823C	Fitting-Superseal 3/8" (10mm)
4	70822C	Fitting-Superseal 1/4" (6mm)
5	51295C	Filter Assy
6	70818C	Elbow-3/8" (10mm)
7	70817C	Elbow-1/4" (6mm)
8	70683C	Union-1/4"

FIG. 4

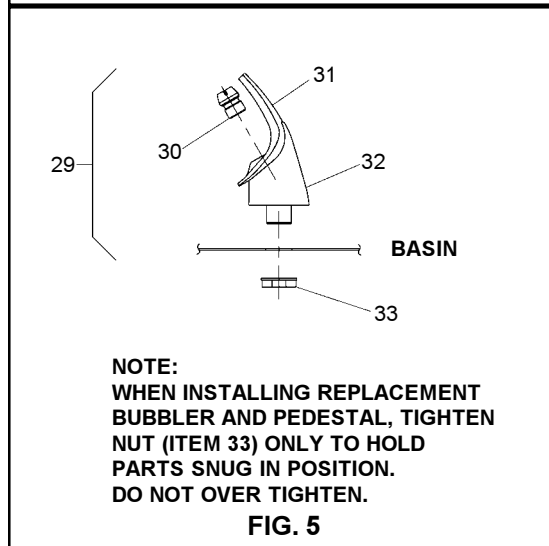

NOTE:
WHEN INSTALLING REPLACEMENT BUBBLER AND PEDESTAL, TIGHTEN NUT (ITEM 33) ONLY TO HOLD PARTS SNUG IN POSITION. DO NOT OVER TIGHTEN.

FIG. 5

*INCLUDES RELAY & OVERLOAD. IF UNDER WARRANTY, REPLACE WITH SAME COMPRESSOR USED IN ORIGINAL ASSEMBLY.

NOTE: All correspondence pertaining to any of the above water coolers or orders for repair parts MUST include Model No. and Serial No. of cooler, name and part number of replacement part.

CAUTION: Cleaning of Bronzestone Models requires special care. Outer surfaces must be cleaned with a mild detergent or mixture of vinegar and water only, rinsed and wiped dry. Abrasive and acidic cleaners may eventually damage the Bronzestone finish.

COLOR TABLE

PANEL COLOR	Item No. 36 Part No.	Item No. 37 Part No.	Item No. 38 Part No.	Item No. 39 Part No.	Item No. 40 Part No.	Item No. 55 Part No.	Item No. 60 Part No.	Item No. 61 Part No.
Bronzestone	26770C	22959C	22966C	26763C	22952C	51552C	26841C	55930C
Gray Beige	26771C	22960C	22967C	26764C	22953C	51551C	26842C	55931C
Almond	26772C	22961C	22968C	26765C	22954C	51552C	26843C	55930C
Stainless Stl	26776C	22854C	22862C	26800C	22955C	51551C	26847C	55931C
Sandalwood	26773C	22962C	22969C	26766C	22956C	51552C	26844C	55930C
Granite	27226C	22965C	22972C	26769C	27214C	51551C	27223C	55931C