

# Installation/Care/Use Manual

## Semi-Recessed Fountain/Cuspidor with FLEXI-GUARD®

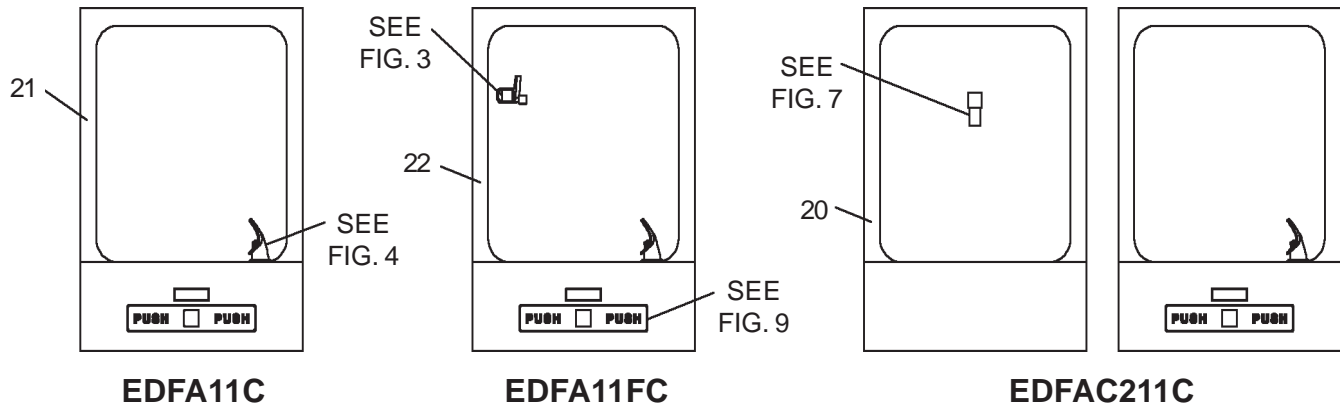

**Installer**

To assure you install this model easily and correctly, PLEASE READ THESE SIMPLE INSTRUCTIONS BEFORE STARTING THE INSTALLATION. CHECK YOUR INSTALLATION FOR COMPLIANCE WITH PLUMBING, ELECTRICAL AND OTHER APPLICABLE CODES. After installation, leave these instructions inside the fountain for future reference.

### IMPORTANT

ALL SERVICE TO BE PERFORMED BY AN AUTHORIZED SERVICE PERSON

#### IMPORTANT! INSTALLER PLEASE NOTE.

THE GROUNDING OF ELECTRICAL EQUIPMENT SUCH AS TELEPHONE, COMPUTERS, ETC. TO WATER LINES IS A COMMON PROCEDURE. THIS GROUNDING MAY BE IN THE BUILDING OR MAY OCCUR AWAY FROM THE BUILDING. THIS GROUNDING CAN CAUSE ELECTRICAL FEEDBACK INTO A FOUNTAIN, CREATING AN ELECTROLYSIS WHICH CAUSES A METALLIC TASTE OR AN INCREASE IN THE METAL CONTENT OF THE WATER. THIS CONDITION IS AVOIDABLE BY USING THE PROPER MATERIALS AS INDICATED. ANY DRAIN FITTINGS PROVIDED BY THE INSTALLER SHOULD BE MADE OF PLASTIC TO ELECTRICALLY ISOLATE THE FOUNTAIN FROM THE BUILDING PLUMBING SYSTEM.

#### INSTALLATION INSTRUCTIONS

1. **Prepare** wall opening(s) and attach wall hanger bracket(s) for the fountain (and cuspidor when applicable) using dimensions shown in Figures 1 and 2.
2. **Water** supply is 3/8" O.D. unplated copper and waste tailpiece(s) are 1-1/4" O.D. Contractor is to supply waste trap(s) and service stop valve in accordance with local codes.
3. **Connecting** lines to be unplated copper and thoroughly flushed to remove all foreign matter before connecting to fountain assembly.
4. **Install** fountain (and cuspidor) into rough-in opening(s).
5. **Connect** the fountain to the supply line with a shut off valve and install a 3/8" (10mm) water line between the valve and strainer. Push the tubes straight into the fittings until they reach a positive stop, approximately 3/4". See Figs. 5 and 6. **DO NOT SOLDER TUBES INSERTED INTO THE STRAINER AS DAMAGE TO THE O-RINGS MAY RESULT.**
6. **On** cuspidor models, connect 1/4 tube coiled in fountain to spreader.
7. **Turn** water supply on and check thoroughly for leaks.
8. **Release** air from tank by depressing push bar; a steady stream of water assures all air is removed.
9. **Re-check** for leaks.
10. **Stream** height is factory set at 35 PSI. If supply pressure varies greatly from this, turn adjustment screw on regulator (item 23). Clockwise adjustment will raise the stream height and counter-clockwise adjustment will lower stream height. For best adjustment, stream should hit basin approximately 6-1/2" from the bubbler.

#### TROUBLE SHOOTING AND MAINTENANCE

1. **Orifice Assy:** Mineral deposits on orifice can cause water flow to spurt or not regulate. Mineral deposits may be removed from orifice with a small round file not over 1/8 diameter or a small diameter wire. **CAUTION: Do not file or cut orifice materials.**
2. **Actuation of Quick Connect Water Fittings:** Cooler is provided with lead-free connectors which utilize an o-ring water seal. To remove tubing from the fitting, relieve water pressure, push in on the gray collar while pulling on the tubing (See Fig. 6). To insert tubing, push tube straight into the fitting until it reaches a positive stop, approximately 3/4".

# EDFA11C ROUGH-IN

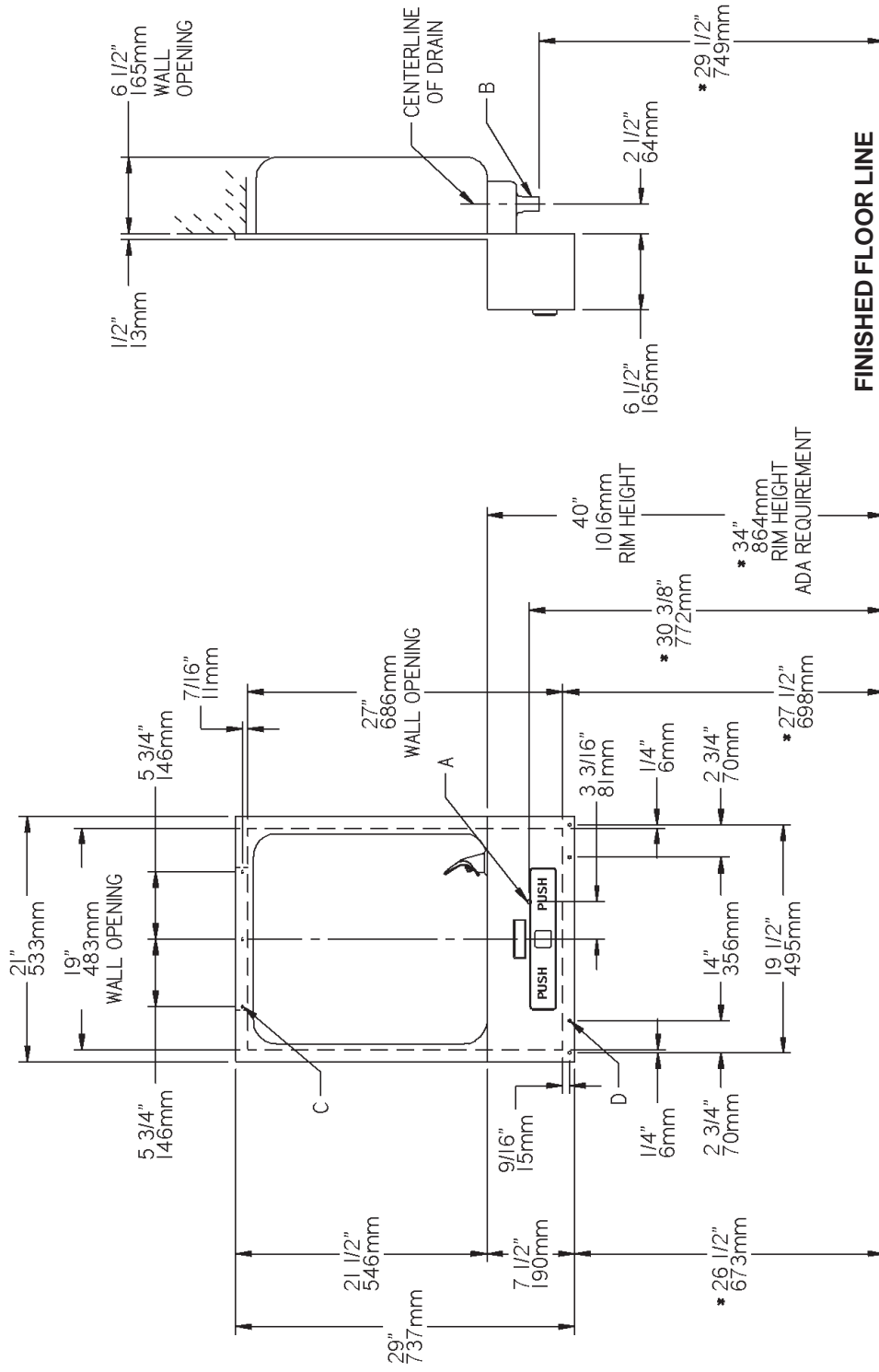

**LEGEND:**  
**A = WATER INLET LOCATION. 3/8" O.D. UNPLATED COPPER TUBE CONNECT.**  
**B = FOUNTAIN WASTE OUTLET LOCATION. 1-1/4" O.D. DRAIN (TRAP NOT FURNISHED)**  
**C = WALL HANGER - 12" (305mm) x 1" (25mm) FURNISHED LOOSE.**  
**D = MOUNTING HOLES FOR 1/4" DIA. (6mm) SCREWS.**

FIG. 1

# EDFAC211C ROUGH-IN

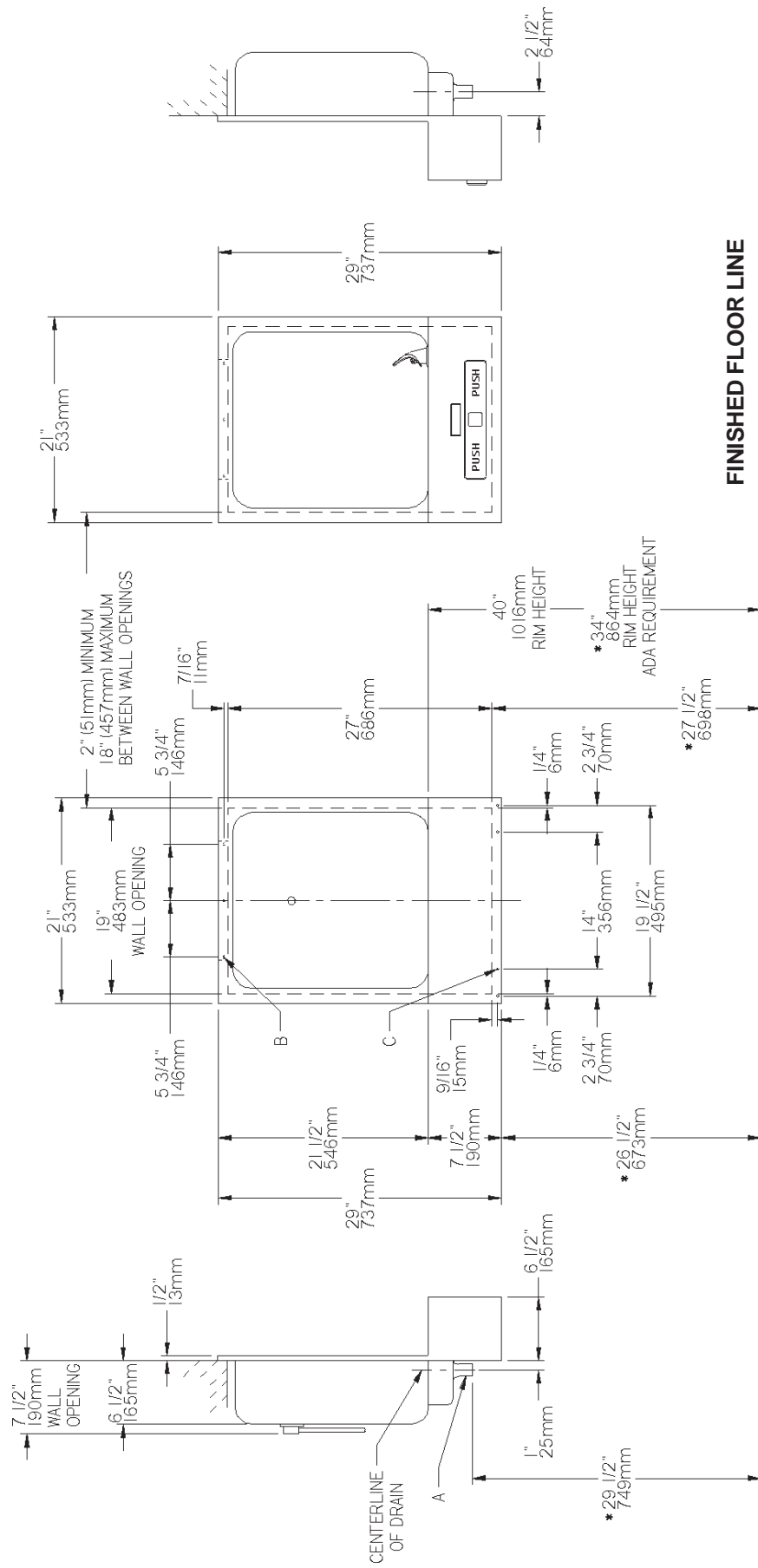

FIG. 2

**LEGEND:**  
**A = CUSPIDOR WASTE OUTLET LOCATION.**  
**B = WALL HANGER - 12" (305mm) x 1" (25mm) FURNISHED LOOSE.**  
**C = MOUNTING HOLES FOR 1/4" DIA. (6mm) SCREWS.**

EDFA11C\*A EDFA11FC\*A EDFAC211C\*A

PARTS LIST		
ITEM NO.	PART NO.	DESCRIPTION
1	15005C	NUT - RETAINING
2	21705C	CLIP - PUSH ROD
3	21708C	PUSH BAR ASSY
4	22911C	BRKT - LEVER PUSH
5	22912C	BRKT - PUSH BAR MTG
6	31525028	O-RING
7	40045C	HEX NUT - UNPLTD
8	40206000	RETAINER
9	40322C	ORIFICE ASSY
10	40493C	GLASS FILLER
11	40572C	TAILPIPE (CUSPIDOR)
12	40575C	STRAINER/FERRULE ASSY
13	40624C	HEAD-SPREADER
14	50074C	GASKET - TAILPIPE
15	55997C	PEDESTAL
16	50198C	BUSHING - SNAP
17	56011C	HOUSING ASSY
18	50986C	HOLDER - REGULATOR
19	56073C	BUBBLER ASSY
20	55001099	CUSPIDOR
21	55001097	FOUNTAIN (EDFA11C)
22	55001098	FOUNTAIN (EDFA11FC)
23	61314C	REGULATOR
24	62084C	TUBE ASSY - GF
25	70002C	SCREW-#10 X .50 HSSM
26	70012C	NUT - 3/8-18 LKNT
27	70018C	NUT 1/4-20 HEX
28	70278C	ROD - SUPPORT
29	70378C	ROD - PUSH
30	55996C	STRAINER
31	70682C	TEE - 1/4"
32	70920C	ROD - PIVOT
33	70971C	ELBOW
34	70977C	NUT - LOCK 1/2 CONDUIT
35	75555C	CLIP -.125 STUD LOCK
36	70683C	UNION 1/4"
37	56092C	POLY TUBING (Cut To Length)
NS	CP11	COVER PLATE (EDFA11C/FC)
NS	28579C	WALL HANGER BRACKET

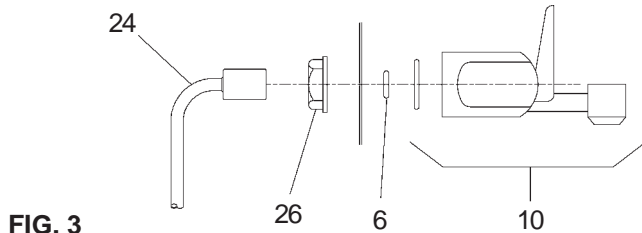

FIG. 3

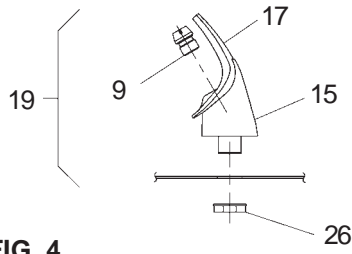

FIG. 4

NOTE: WHEN INSTALLING REPLACEMENT BUBBLER AND PEDESTAL, TIGHTEN NUT (ITEM 26) ONLY TO HOLD PARTS SNUG IN POSITION. DO NOT OVER TIGHTEN.

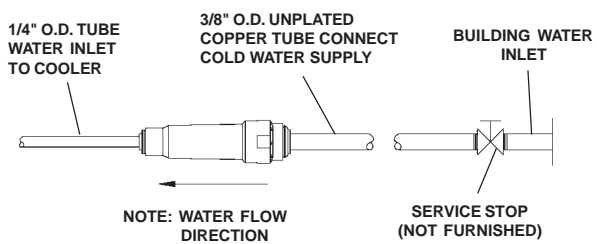

FIG. 5

OPERATION OF QUICK CONNECT FITTINGS

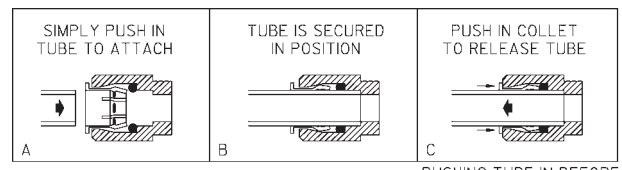

FIG. 6

PUSHING TUBE IN BEFORE PULLING IT OUT HELPS TO RELEASE TUBE

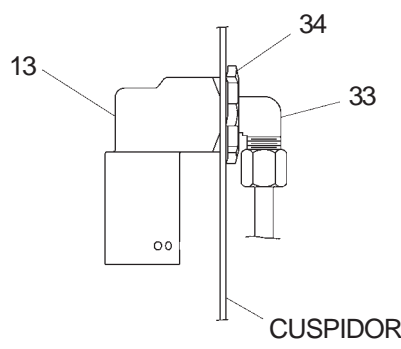

FIG. 7

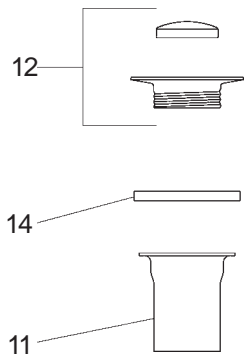

FIG. 8

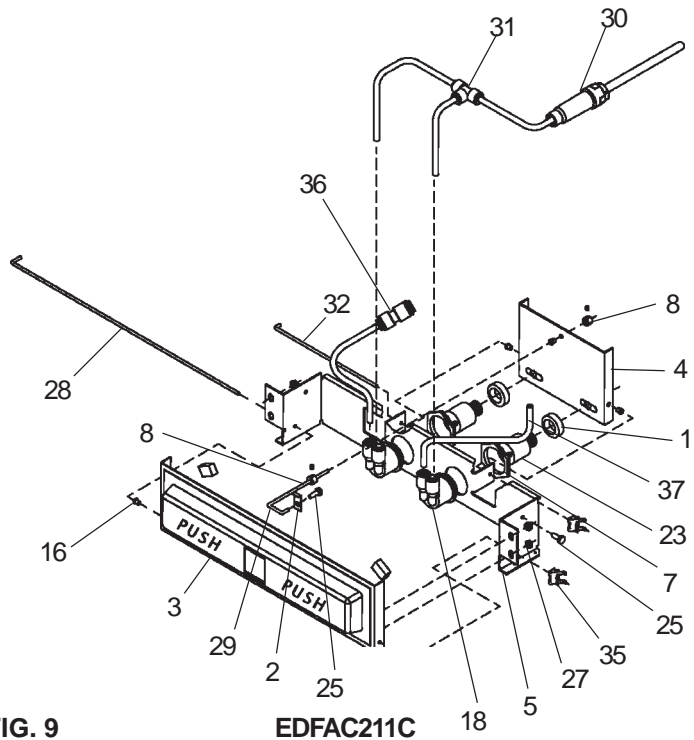

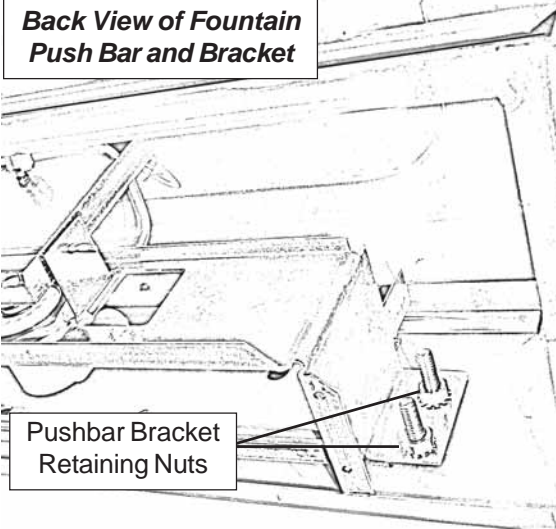
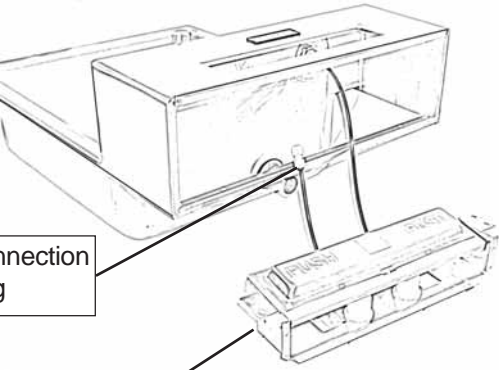

FIG. 9

EDFAC211C

# Installation Notes

<p><b>Plumbing Connection Access</b></p> <p>To gain additional access (for Drain Trap and Water Line Connections) the front push bar can be removed during installation.</p>	 <p>Front Push Bar</p>
<p><b>Front Push Bar Removal</b></p> <p>The push bar is removed by unfastening the four retaining nuts on the back side of the pushbar mounting bracket.</p>	<p><b>Back View of Fountain Push Bar and Bracket</b></p>  <p>Pushbar Bracket Retaining Nuts</p>
<p><b>Plumbing Connections</b></p> <p>Removing the Pushbar Bracket Assembly increases access to the drain and water connections.</p> <p>Note: For Cuspidor Units the cuspidor supply line must be connected or capped before use.</p>	<p><b>Fountain with Push Bar Removed</b></p>  <p>Cuspidor Connection Fitting</p> <p>Pushbar and Mounting Bracket Assembly</p>