

Installation/Care/Use Manual

EDFP(W)110C EDP(W)114C EDP117C

Swirlflo® Fountains with FLEXI-GUARD®

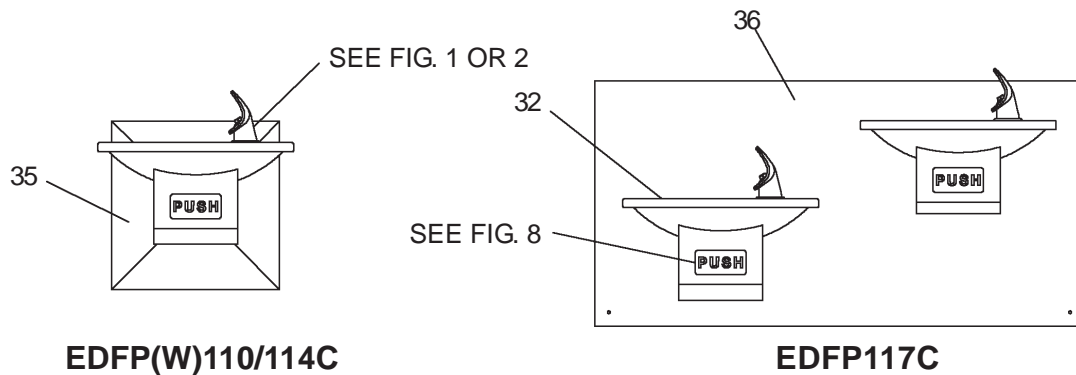

Installer

To assure you install this model easily and correctly, PLEASE READ THESE SIMPLE INSTRUCTIONS BEFORE STARTING THE INSTALLATION. CHECK YOUR INSTALLATION FOR COMPLIANCE WITH PLUMBING, ELECTRICAL AND OTHER APPLICABLE CODES. After installation, leave these instructions inside the fountain for future reference.

IMPORTANT

ALL SERVICE TO BE PERFORMED BY AN AUTHORIZED SERVICE PERSON

IMPORTANT! INSTALLER PLEASE NOTE.

THE GROUNDING OF ELECTRICAL EQUIPMENT SUCH AS TELEPHONE, COMPUTERS, ETC. TO WATER LINES IS A COMMON PROCEDURE. THIS GROUNDING MAY BE IN THE BUILDING OR MAY OCCUR AWAY FROM THE BUILDING. THIS GROUNDING CAN CAUSE ELECTRICAL FEEDBACK INTO A FOUNTAIN, CREATING AN ELECTROLYSIS WHICH CAUSES A METALLIC TASTE OR AN INCREASE IN THE METAL CONTENT OF THE WATER. THIS CONDITION IS AVOIDABLE BY USING THE PROPER MATERIALS AS INDICATED. ANY DRAIN FITTINGS PROVIDED BY THE INSTALLER SHOULD BE MADE OF PLASTIC TO ELECTRICALLY ISOLATE THE FOUNTAIN FROM THE BUILDING PLUMBING SYSTEM.

FIG. 1

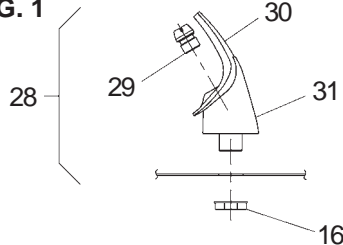

NOTE: When installing replacement bubbler and pedestal, tighten locknut (Item 16 or 38) only to hold parts snug in position. **DO NOT OVERTIGHTEN.**

FIG. 2

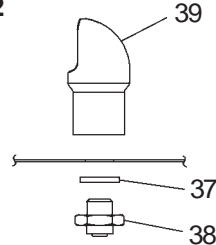
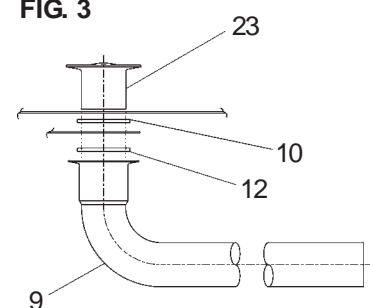

FIG. 3



INSTALLATION INSTRUCTIONS

- Wall** should already be framed for the fountain using the positioning dimensions shown in Figures 4 or 5. Shown dimensions pertain to installation location (framing must support up to 150 lbs. weight). These dimensions are required for compliance with ANSI Standard A117.0.
- Install** rough-in plumbing as shown in Figures 4 or 5. Run the supply water inlet line through the back panel. Install a service stop (not provided). Turn on supply water and flush thoroughly.
- Remove** bottom access panel from fountain basin and save the screws. Install the fountain to the back panel and wall using (4) 5/16" nuts to attach to the mounting bracket rods.
- Determine** required length of waste line and cut to appropriate length. 1-1/4" O.D. waste tube furnished. 1-1/4" slip trap, waste elbow and extension not provided.
- Make** water supply connections from service stop to the 3/8" O.D. unplated copper tube coming out of the strainer. Turn on water supply and check for leaks. Newly installed water supply line should be insulated after leak check is completed. **DO NOT SOLDER TUBES INSERTED INTO THE STRAINER AS DAMAGE TO THE O-RINGS MAY RESULT.**
- These** products are designed to operate on 20-105 PSIG supply line pressure. If inlet pressure is above 105 PSIG, a pressure regulator must be installed in the supply line. Any damage caused by reason of connecting these products to supply line pressures lower than 20 PSIG or higher than 105 PSIG is not covered by warranty.
- Check** stream height from bubbler. Stream height is factory set at 35 PSI. If supply pressure varies greatly from this, turn adjustment screw on the regulator (Item 14). Clockwise adjustment will raise stream height and counter-clockwise will lower stream height. For best adjustment stream should hit basin approximately 6-1/2" (165mm) from bubbler.
- Replace** bottom access panel to fountain using the screws provided. Tighten securely.

EDFP(W)110/114C ROUGH-IN

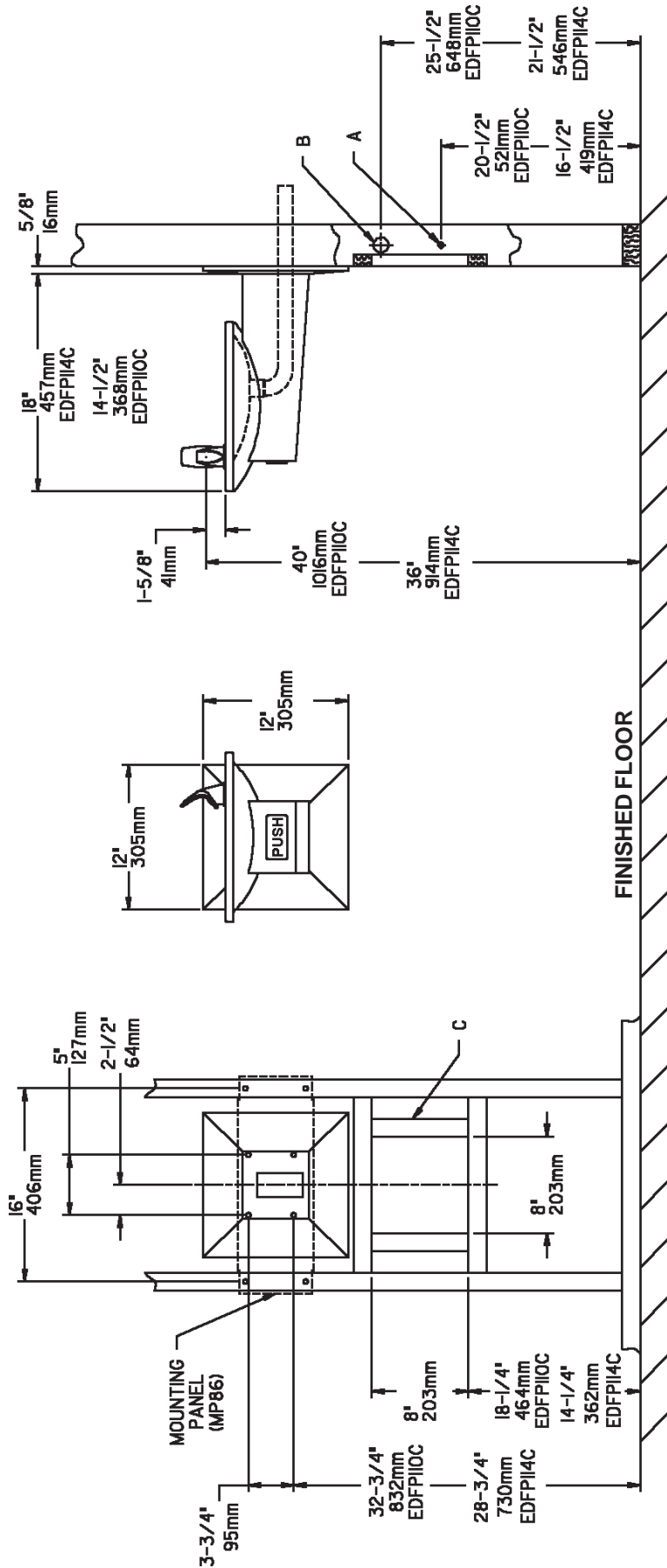

FIG. 4

- LEGEND:**
- A** = WATER INLET LOCATION LEFT OR RIGHT SIDE. 3/8" O.D. UNPLATED COPPER TUBE CONNECT.
 - B** = FOUNTAIN WASTE LOCATION LEFT OR RIGHT SIDE. WASTE IS SHOWN IN WALL BUT MAY BE BEHIND WALL. 1-1/4" O.D. DRAIN (TRAP NOT FURNISHED).
 - C** = FRAMING REQUIRED WHEN OPTIONAL AP-99 ACCESS PANEL IS USED.

EDFP117C ROUGH-IN

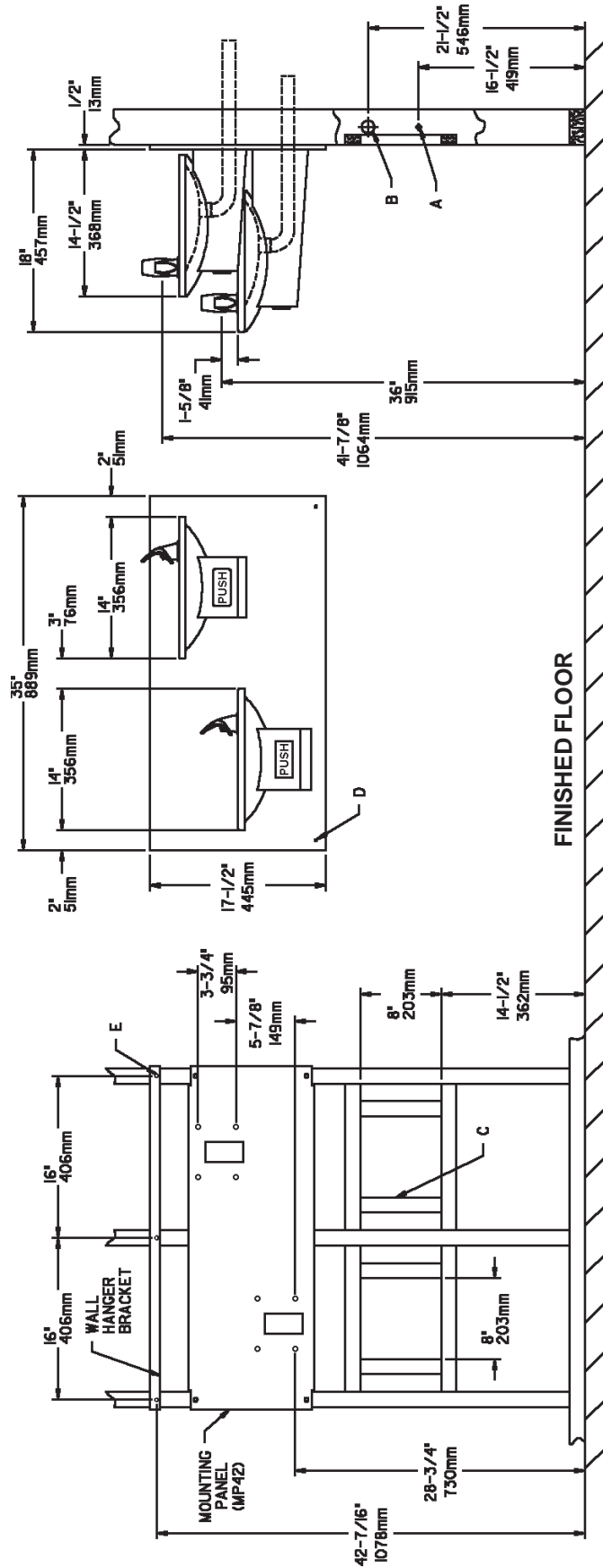

FIG. 5

- LEGEND:**
A = WATER INLET LOCATION LEFT OR RIGHT SIDE. 3/8" O.D. UNPLATED COPPER TUBE CONNECT.
B = FOUNTAIN WASTE LOCATION LEFT OR RIGHT SIDE. WASTE IS SHOWN IN WALL BUT MAY BE BEHIND WALL. 1-1/4" O.D. DRAIN (TRAP NOT FURNISHED).
C = FRAMING REQUIRED WHEN OPTIONAL AP-99 ACCESS PANEL IS USED.
D = 3/16" DIA. (5mm) HOLES.
E = 3/8" DIA. (10mm) HOLES.

PARTS LIST		
ITEM NO.	PART NO.	DESCRIPTION
1	15005C	RETAINING NUT
2	21705C	CLIP-PUSH ROD
3	28321C	REGULATOR MOUNTING BRACKET
4	28322C	PUSH BAR MOUNTING BRACKET
5	28324C	REGULATOR ACTIVATING ARM
6	28325C	PIVOT ROD BRACKET
7	40045C	HEX NUT
8	40206000	RETAINER
9	45330C	WASTE ARM TUBE
10	50074C	GASKET-TAILPIPE
11	50198C	BUSHING-SNAP
12	50377C	GASKET-TAILPIPE
13	50986C	REGULATOR HOLDER
14	61313C	REGULATOR
15	70002C	SCREW-#10 X .50 HHSM
16	75580C	NUT-3/8-18 LKNT
17	70208C	SCREW-#10-24 X .38 PHTC
18	70378C	ROD-PUSH
19	70410C	ROD-PIVOT
20	70425C	ROD-PIVOT
21	75555C	CLIP-.125 STUD LOCK
22	21810C	PUSH BAR ASSY
23	45336C	STRAINER & FERRULE ASSY
24	21822C	FTN BODY & SHELL ASSY (EDFP110C)
25	21823C	FTN BODY & SHELL ASSY (EDFP114C)
26	21845C	COVER PLATE (EDFP110C)
27	21846C	COVER PLATE (EDFP114C)
28	56073C	BUBBLER ASSY
29	40322C	ORIFICE ASSY
30	56011C	HOUSING ASSY
31	55997C	PEDESTAL
32	55001026	BASIN
33	70055C	NUT-SPEED
34	112627543890	SCREW-#8-32 X .25 THMS
35	55000940	BACK PANEL ASSY (EDFP110/114C)
36	55000941	BACK PANEL ASSY (EDFP117C)
37	100322740560	GASKET (VR MODEL ONLY)
38	15009C	NIPPLE - BUBBLER (VR MODEL ONLY)
39	98118C	BUBBLER ASSEMBLY (VR MODEL ONLY)
NS	55996C	STRAINER
NS	56092C	POLY TUBING (CUT TO LENGTH)

OPERATION OF QUICK CONNECT FITTINGS

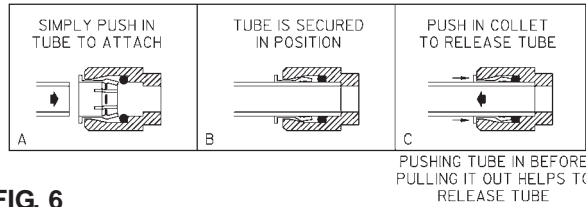

FIG. 6

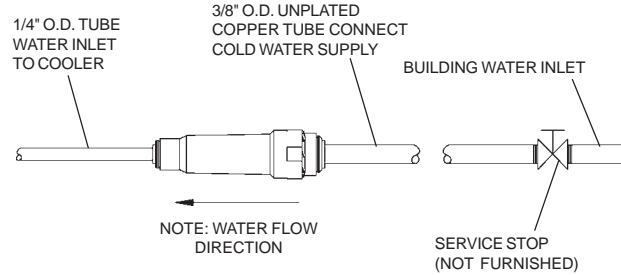

FIG. 7

TROUBLE SHOOTING AND MAINTENANCE

- Orifice Assy:** Minerals deposits on orifice can cause water flow to spurt or not regulate. Mineral deposits may be removed from the orifice with a small round file not over 1/8" diameter or a small diameter wire.
CAUTION: Do not file or cut orifice materials.
- Stream Regulator:** If orifice is free of material deposits regulate water flow according to instructions on page 1.

FIG. 8

