

With FLEXI-GUARD®

Installation/Care/Use Manual

USES HFC-134A REFRIGERANT

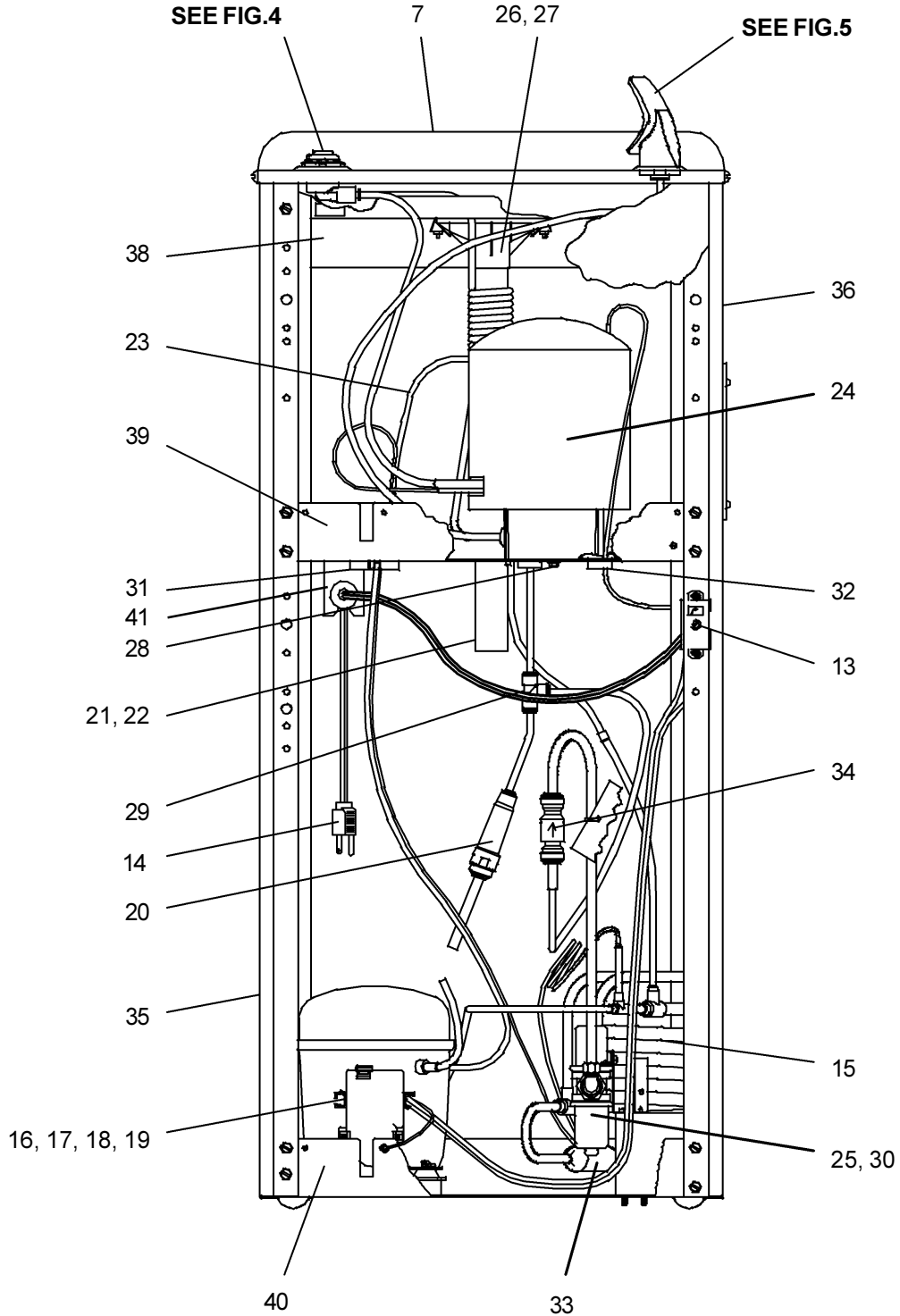

FIG. 1

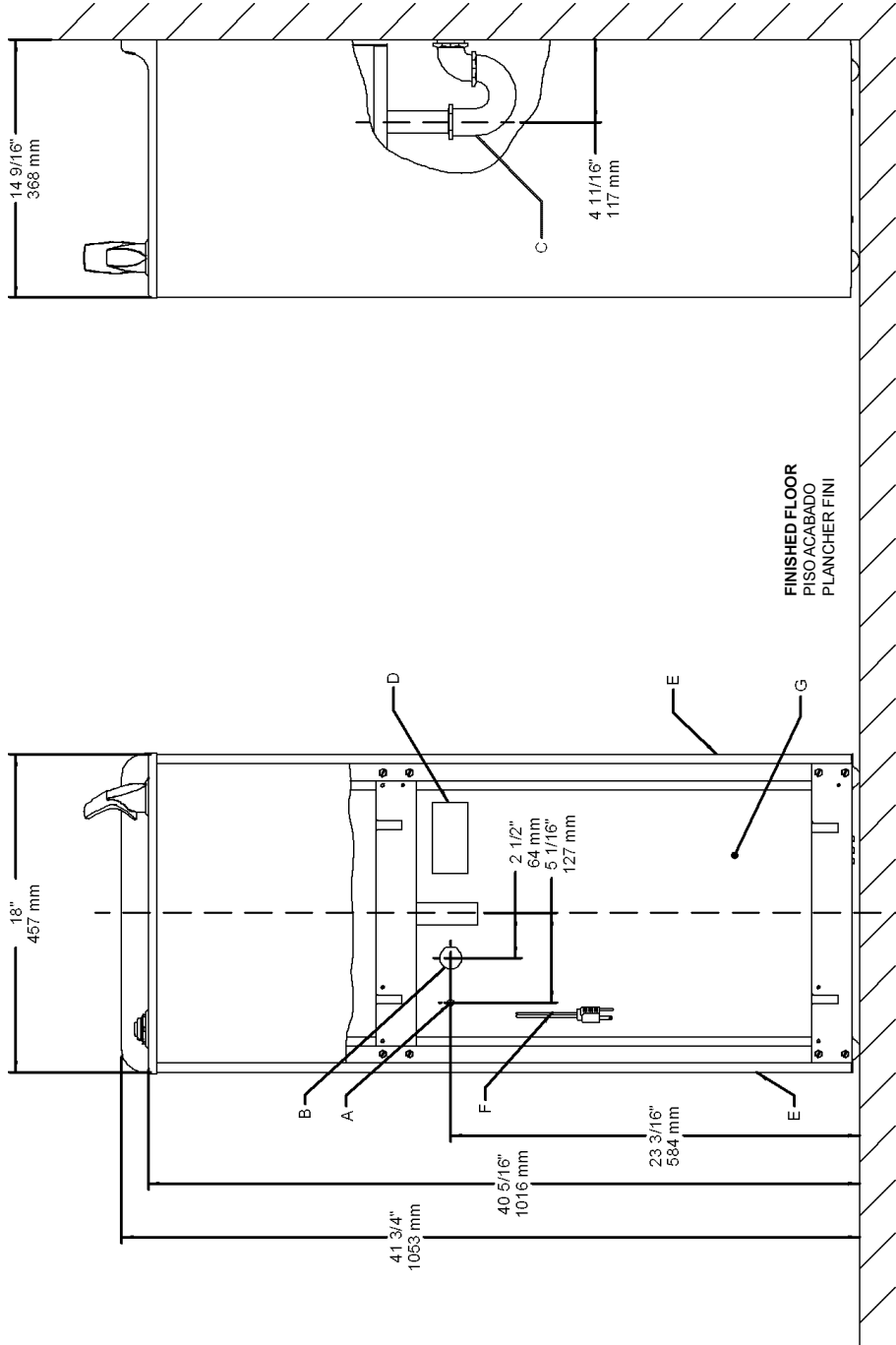

FIG. 2

E = INSURE PROPER VENTILATION BY MAINTAINING 4" (102mm) (MIN.) CLEARANCE FROM CABINET LOUVERS TO WALL
 ASEGURE UNA VENTILACION ADECUADA MANTENIENDO UN ESPACIO E 4" (102mm) (MIN.) DE HOLGURA ENTRE LA REJILLA DE VENTILACION DEL MUEBLE Y LA PARED
 ASSUREZ-VOUS UNE BONNE VENTILATION EN GARDANT 4" (102mm) (MIN.) ENTRE LES EVENTS DE L'ENCEINTE ET LE MUR.
F = POWER CORD 4 FEET (1219mm) LONG
 CABLE ELECTRICO DE 4 PIE (1219mm), DE LARGO
 CORDON D'ALIMENTATION 4' (1219mm)
G = PLUMBING ROUGH-IN CAN BE LOCATED ANYWHERE WITHIN THIS AREA.
 SE PUEDE COLOCAR EL DESBASTE DE LA TUBERIA EN CUALQUIER LUGAR DENTRO DE ESTA AREA.
 ON PEUT PLACER LA TUYAUTERIE DANS CETTE REGION.

LEGEND/LEYENDA/LÉGENDE
A = RECOMMENDED WATER SUPPLY LOCATION 3/8 O.D. UNPLATED COPPER TUBE CONNECT STUB 1-1/2 IN. (38mm) OUT FROM WALL SHUT OFF BY OTHERS
 SE RECOMIENDA UBICAR EL TUBO CORTO DE CONEXIÓN AL TUBO DE COBRE SIN CHAPAR DE 3/8" DE DIÁM. EXT. A 1-1/2" (38mm) FUERA DE LA LAVE DE PASO EN LA PARED COLOCADA POR TERCEROS.
 EMPLACEMENT RECOMMANDÉ D'ALIMENTATION EN EAU PAR TUBE EN CUIVRE NON PLAQUÉ DE 3/8 PO. (9.5 mm) D.E. CONNECTANT UNE TUYAUTERIE DE 1-1/2 PO. (38mm) DEPUIS LE ROBINET D'ARRÊT FOURNI PAR D'AUTRES.
B = RECOMMENDED LOCATION FOR WASTE OUTLET 1-1/4" O.D. DRAIN
 UBICACION RECOMENDADA PARA EL DRENAJE DE SALIDA DE AGUA. DE 1 1/4" DE DIÁMETRO.
C = 1-1/4 TRAP NOT FURNISHED**
 PURGADOR DE 1 1/4 NO PROPORCIONADO**
D = ELECTRICAL OUTLET LOCATION
 UBICACION DE LA TOMA DE ELECTRICIDAD
 EMPLACEMENT DE LA PRISE DE COURANT

CONDENSER WATER VALVE ADJUSTMENT

The condenser water valve is factory preset for a condenser water outlet temperature of 95° to 105° F. If actual temperature varies greatly from this, readjust water flow rate at the valve using the following procedures.

1. START UP COMPRESSOR

This can be accomplished by depressing the cooler push button (See Fig. 4 - Item 2). Keep water running during the entire readjustment procedure.

2. ADJUSTMENT CONDENSER WATER VALVE

Adjust valve by rotating adjustment stem. Rotating stem clockwise will decrease water flow. Counterclockwise rotation will increase water flow. Increasing water flow will result in a lower condenser outlet temperature, while decreasing water flow will result in a higher outlet temperature. Proper adjustment is attained when condenser outlet temperature is 95° to 105° F.

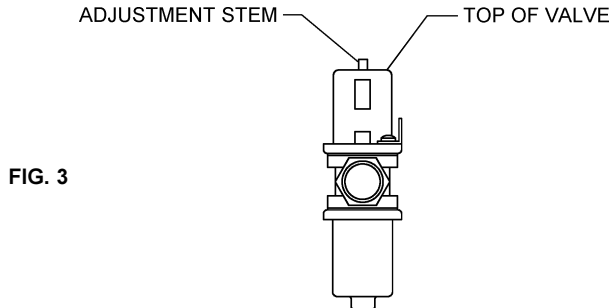

FIG. 3

Stream height is factory set at 35 PSI. If supply pressure varies greatly from this, remove items 1 & 2 and adjust screw on item 4. Clockwise adjustment will raise stream and counter-clockwise adjustment will lower stream. For best adjustment, stream should hit basin approximately 6-1/2" (165mm) from bubbler.

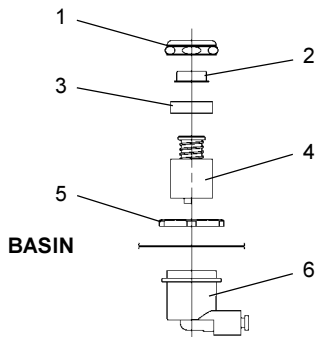
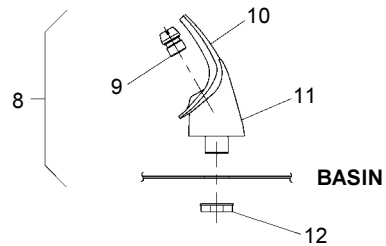

FIG. 4



NOTE:
WHEN INSTALLING REPLACEMENT BUBBLER AND PEDESTAL, TIGHTEN NUT (ITEM 12) ONLY TO HOLD PARTS SNUG IN POSITION. DO NOT OVER TIGHTEN.

FIG. 5

WIRING DIAGRAM

This Drawing is merely for illustrating the components of the electrical system.

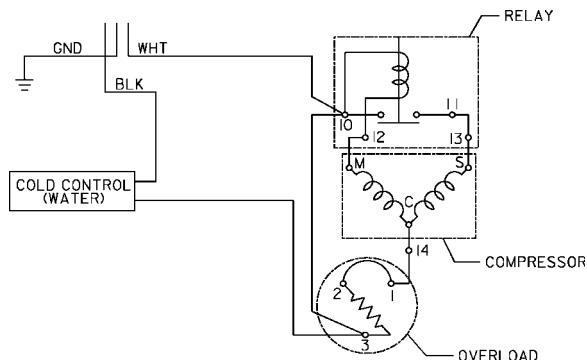

PARTS LIST 115V

ITEM NO.	PART NO.	DESCRIPTION
1	40089C	Cover
2	40048C	Button
3	15005C	Regulator Retaining Nut
4	61313C	Regulator
5	40169C	Hex Nut
6	50986C	Regulator Holder
7	20776C	Basin
8	51349C	Bubbler Assy
9	40322C	Orifice Assy
10	50934C	Housing Assy
11	50168C	Pedestal
12	70012C	Bubbler Locknut
13	31513C	Cold Control
14	30268C	Power Cord
15	45395C	Condenser Assy
16*	35762C	Compressor Serv. Pak
17	31027C	Overload/Relay Assy
18	31797C	Relay Cover
19	194243901550	Electrical Shield
20	55996C	Strainer
21	45690C	Precooler
22	55909C	Tailpipe Helix
23	66229C	Heat Exchanger
24	66506C	Evaporator
25	40136C	Water Temperature Valve
26	50368C	Receptor - Drain
27	70750C	Clamp - Hose
28	75568C	Screw - Evaporator Mtg
29	70682C	Tee - 1/4
30	70233C	Elbow - 1/4 x 3/8
31	55981C	Snap Bushing
32	51454C	Snap Bushing
33	66202C	Drier
34	75494C	Check Valve 3/8
35	SEE TABLE	Panel - Left
36	SEE TABLE	Panel - Right
37	SEE TABLE	Panel - Front (not shown)
38	20708C	Brace - Cross
39	22540C	Shelf
40	22547C	Baseplate
41	27961C	Bracket - Strain Relief
NS	56092C	Tubing Poly (Cut to Length)

220/240v 50Hz

ITEM NO.	PART NO.	DESCRIPTION
14	31440C	Power Cord
16*	35764C	Compressor Serv. Pak
17	31028C	Overload/Relay Assy
18	35768C	Relay Cover 220V

*INCLUDES RELAY & OVERLOAD. IF UNDER WARRANTY, REPLACE WITH SAME COMPRESSOR USED IN ORIGINAL ASSEMBLY.

NOTE: All correspondence pertaining to any of the above water coolers or orders for repair parts MUST include Model No. and Serial No. of cooler, name and part number of replacement part.

COLOR TABLE				
PANEL COLOR	Item No. 35 Part No.	Item No. 36 Part No. (w/o hole)	Item No. 36 Part No. (w/ hole)	Item No. 37 Part No.
Gray Beige	20622C	27653C	20623C	20657C
Almond	21460C	27655C	24161C	20658C
Stainless Steel	20624C	27652C	20625C	20654C
Sandalwood	21458C	27656C	21459C	21450C
Granite	27165C	27654C	27168C	27147C
Light Gray Granite	27166C	27657C	N/A	27148C