

With FLEXI-GUARD®

Installation/Care/Use Manual

USES HFC-134A REFRIGERANT

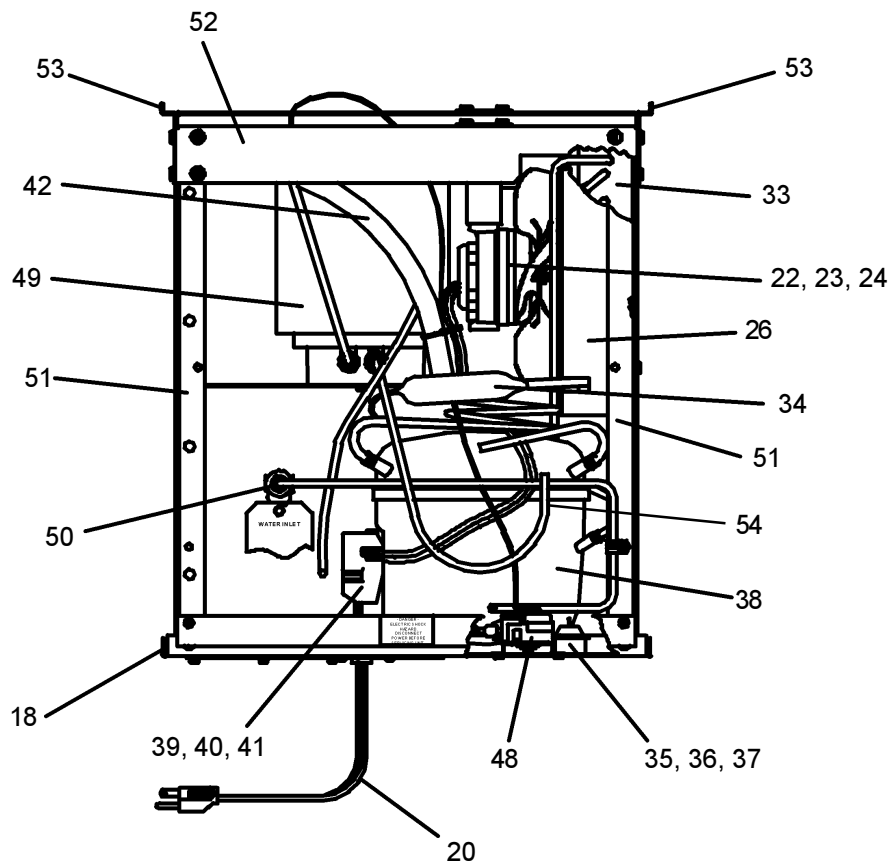
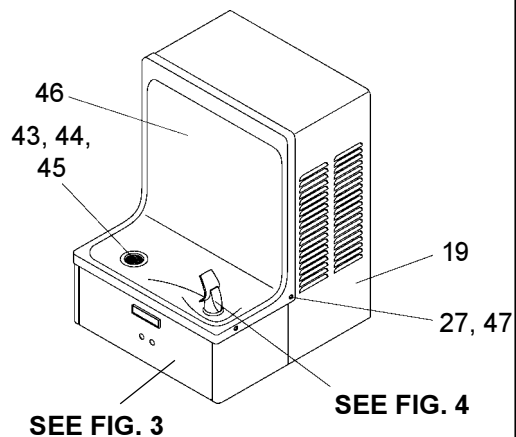
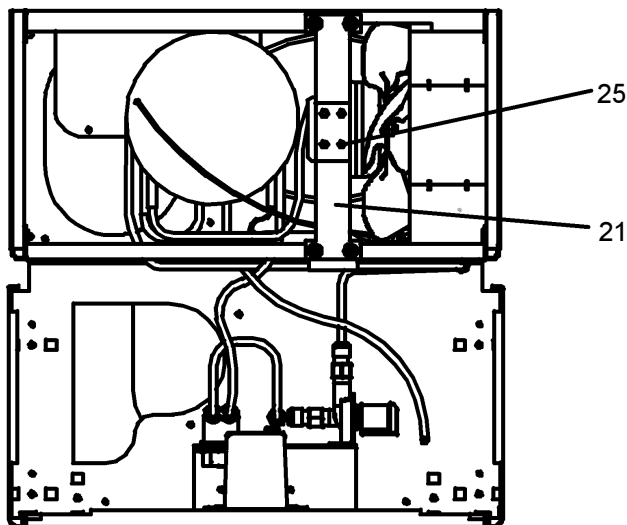

FIG. 1

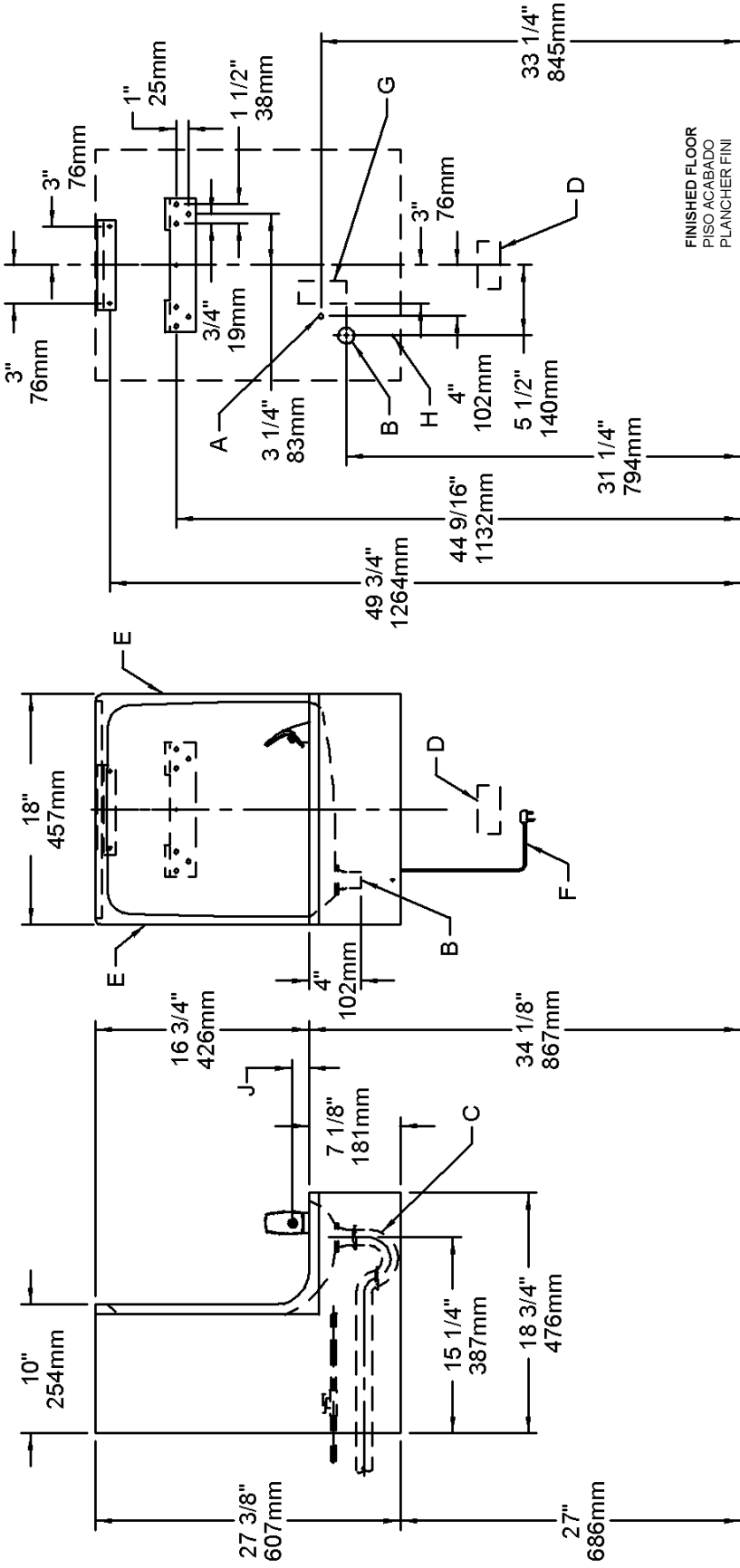

FIG. 2

E = INSURE PROPER VENTILATION BY MAINTAINING 6" (152mm) (MIN.) CLEARANCE FROM CABINET LOUVERS TO WALL. ASEGURE UNA VENTILACION ADECUADA MANTENIENDO UN ESPACIO E 6" (152mm) (MIN.) DE HOLGURA ENTRE LA REJILLA DE VENTILACION DEL MUEBLE Y LA PARED. ASSUREZ-VOUS UNE BONNE VENTILATION EN GARDANT 6" (152mm) (MIN.) ENTRE LES ÉVÉNENTS DE L'ENCEINTE ET LE MUR.

F = POWER CORD 1-1/2FEET (457mm) LONG. CABLE ELÉCTRICO DE 1½ PIE. 457 mm DE LARGO. CORDON D'ALIMENTATION 1-1/2' (457mm)

G = ALT. ELECTRICAL OUTLET LOCATION. UBICACION ALT. DE LA TOMA DE ELECTRICIDAD. EMPLACEMENT ALTERNATIF DE LA PRISE DE COURANT.

H = THIS BOLT HOLE MUST BE USED FOR FASTENING UNIT TO WALL. ESTE AGUJERO DE TUERCA DEBERÁ SER USADO PARA ASEGURAR LA UNIDAD A LA PARED. ON DOIT UTILISER CE TROU DE BOLLON POUR INSTALLER L'APPAREIL AU MUR.

J = ORIFICE HEIGHT 1-1/4" (32mm) ABOVE RIM. ALTURA DEL ORIFICIO 1-1/4" (32mm) SOBRE LA CORONA. HAUTEUR DE L'ORIFICE 1-1/4" (32mm) AUDESSUS DU REBORD.

LEGEND/LEYENDA/LÉGENDE

A = RECOMMENDED WATER SUPPLY LOCATION 3/8 O.D. UNPLATED COPPER TUBE CONNECT STUB 1-1/2 IN. (38mm) OUT FROM WALL SHUT OFF BY OTHERS. SE RECOMIENDA UBICAR EL TUBO CORTO DE CONEXIÓN AL TUBO DE COBRE SIN CHAPAR DE 3/8" DE DIAM. EXT. A 1-1/2" (38mm) FUERA DE LA LLAVE DE PASO EN LA PARED COLOCADA POR TERCEROS. EMPLACEMENT RECOMMANDÉ D'ALIMENTATION EN EAU PAR TUBE EN CUIVRE NON PLAQUÉ DE 3/8 PO. (9,5 mm) D.E. CONNECTANT UNE TUYAUTERIE DE 1-1/2 PO. (38mm) DEPUIS LE ROBINET D'ARRÊT FOURNI PAR D'AUTRES.

B = RECOMMENDED LOCATION FOR WASTE OUTLET 1-1/4" O.D. DRAIN. UBICACION RECOMENDADA PARA EL DRENAJE DE SALIDA DE AGUA, DE 1½" DE DIÁMETRO. EMPLACEMENT RECOMMANDÉ POUR LE DRAIN DE D.E. 1-1/4" DE SORTIE D'EAU.

C = 1-1/4 TRAP NOT FURNISHED. PURGADOR DE 1½ NO PROPORCIONADO**. SIPHON 1-1/4 NON FOURNI**.**

D = ELECTRICAL OUTLET LOCATION. UBICACION DE LA TOMA DE ELECTRICIDAD. EMPLACEMENT DE LA PRISE DE COURANT.

SENSOR RANGE ADJUSTMENT: The electronic sensor used in this cooler is factory pre-set for a "visual" range of 36 inches (914 mm). If actual range varies greatly from this or a different setting is desired, follow the range adjustment procedure below:

- A. Remove front panel of cooler.
- B. Using a small tip screwdriver, rotate range adjustment screw clockwise to increase range and counterclockwise to decrease range (See Fig. 3).

CAUTION: Complete range of sensor (24-28 inches/610-711mm) is only one turn of the adjusting screw.

- C. Replace front panel.

SENSOR CONTROL: If sensor fails to operate valve mechanism or operates erratically, check the following.

- A. Ensure there are no obstructions within a 40 inch (1016mm) radius in front of cooler.
- B. Check wire connections at the solenoid valve and sensor. **CAUTION:** Make sure unit is unplugged before checking any wiring.
- C. Ensure proper operation of solenoid valve. If there is an audible clicking sound yet no water flows, look for an obstruction in the valve itself or elsewhere in the water supply line.

FIG. 3

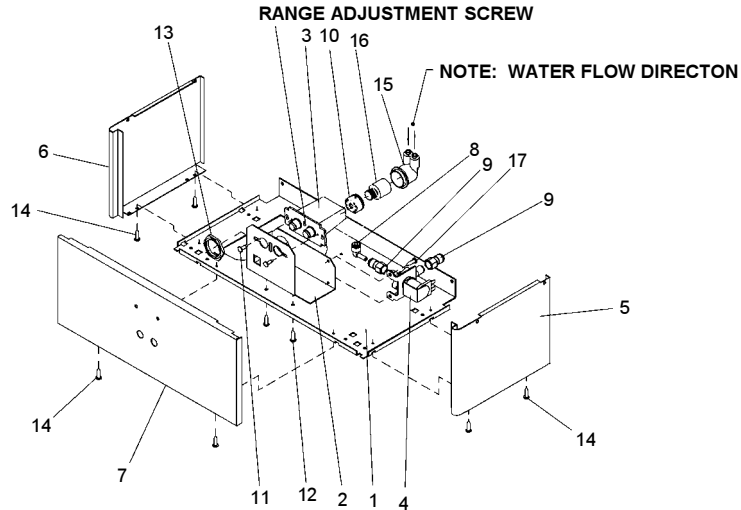

HANGER BRACKETS & TRAP INSTALLATION

- 1) Remove hanger bracket fastened to back of cooler by removing one (1) screw.
- 2) Mount the hanger bracket and trap as shown in Figure 2. **NOTE:** Hanger Bracket MUST be supported securely. Add fixture support carrier if wall will not provide adequate support.

IMPORTANT:

- 7-3/4 in. (197mm) dimension from wall to centerline of trap must be maintained for proper fit.
- Anchor hanger securely to wall using all six (6) 1/4 in. dia. mounting holes.

- 3) Install straight valve for 3/8" O.D. unplated copper tube.

INSTALLATION OF COOLER

- 4) Hang the cooler on the hanger bracket. Be certain the hanger bracket is engaged properly in the slots on the cooler back as shown in Figure 2.
- 5) Loosen the two (2) screws holding the lower front panel at the bottom of cooler base and two (2) screws at the top. Remove the front panel and set aside.
- 6) Connect water inlet line--See Note 4 of General Instructions.
- 7) Remove the slip nut and gasket from the trap and install them on the cooler waste line making sure that the end of the waste line fits into the trap. Assemble the slip nut and gasket to the trap and tighten securely.

START UP

Also See General Instructions

- 8) Stream height is factory set at 35 PSI. If supply pressure varies greatly from this, adjust screw, accessible by removing front panel (Item 7, Fig. 3). CW adjustment will raise stream and CCW adjustment will lower stream. For best adjustment, stream should hit basin approximately 6-1/2" (165mm) from bubbler.
- 9) Replace the front panel and secure by retightening four (4) screws.

ITEM NO.	PART NO.	DESCRIPTION
1	26588C	Panel-Bottom Dispenser
2	26866C	Bracket-Valve Mounting
3	31516C	Sensor-Clear (115V)
	35783C	Sensor-Clear (230V)
4	31272C	Solenoid Valve (115V)
	35784C	Solenoid Valve (230V)
5	See Color Table	Panel-Right Side
6	See Color Table	Panel-Left Side
7	See Color Table	Panel-Front
8	70817C	Elbow 1/4 Stem x 1/4 O.D.
9	75507C	Fitting 1/4 NPTF x 1/4 O.D.
10	56082C	Nut-Regulator
11	70644C	Screw-#6-32 x 1/2" Lg. PHMS
12	75497C	Screw-#10 x 1/2" Lg. PHSM
13	40045C	Hex Nut
14	70864C	Screw-#8 x 5/8" Lg. Torx/Slot
15	50986C	Holder-Regulator
16	61314C	Regulator
17	70002C	Screw-#10 x 1/2" Lg. HHSM

COLOR TABLE

PANEL COLOR	Item No. 5 Part No.	Item No. 6 Part No.	Item No. 7 Part No.
Gray Beige	26635C	26605C	26731C
Almond	26636C	26606C	26732C
Stainless Stl	26637C	26607C	26733C
Sandalwood	26638C	26608C	26734C
Granite	26641C	26611C	26737C
Light Gray	26642C	26612C	26738C

PARTS LIST 115V

ITEM NO.	PART NO.	DESCRIPTION
18	27097C	Frame-Back/Bottom
19	See Color Table	Wrapper
20	31483C	Power Cord
21	27095C	Fan Bracket
22	30699C	Fan Blade
23	70018C	Hex Nut - Fan Blade
24	31490C	Fan Motor 115V
25	70009C	Screw - Fan Motor
26	50186C	Shroud - Fan
27	70241C	Clip (Front and Rear Panels)
28	56073C	Bubbler Assembly
29	40322C	Orifice Assembly
30	55997C	Pedestal
31	56011C	Housing Assembly
32	75580C	Locknut
33	62152C	Condenser
34	66202C	Drier
35	50144C	Grommet - Compressor Mtg.
36	70184C	Hair Pin - Cotter
37	70150C	Washer
38*	35947C	Compressor Serv. Pak EM65
39	31039C	Overload/Relay P600B/427NFBYY
40	35768C	Cover - Relay
41	35935C	Capacitor - Run
42	66501C	Heat Exchanger
43	40572C	Tailpipe
44	40575C	Strainer Assy
45	50074C	Gasket - Tailpipe
46	21222C	Basin
47	70208C	Screw - Basin Mtg.
48	31513C	Cold Control
49	66505C	Evaporator Assy
50	55996C	Strainer
51	27093C	Angle - Bracket Corner
52	27094C	Bracket - Front Support
53	27096C	Bracket - Basin Mtg.
54	56092C	Poly Tubing (Cut To Length)

***INCLUDES RELAY & OVERLOAD. IF UNDER WARRANTY, REPLACE WITH SAME COMPRESSOR USED IN ORIGINAL ASSEMBLY.**

NOTE: All correspondence pertaining to any of the above water coolers or orders for repair parts MUST include Model No. and Serial No. of cooler, name and part number of replacement part.

COLOR TABLE	
PANEL COLOR	Item No. 55 Part No.
Gray Beige	22706C
Almond	22707C
Stainless Steel	22708C
Sandalwood	22709C
Granite	22711C
Light Gray	22712C

PARTS LIST 230V

ITEM NO.	PART NO.	DESCRIPTION
24	31430C	Fan Motor
*38	35763C	Compressor Serv. Pak
40	31024C	Overload/Relay
41	35768C	Cover-Relay
42	66552C	Heat Exchanger
-	194243901550	Cover-Electrical Shield

WIRING DIAGRAM

This Drawing is merely for illustrating the components of the electrical system.

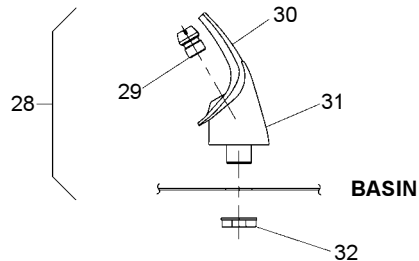
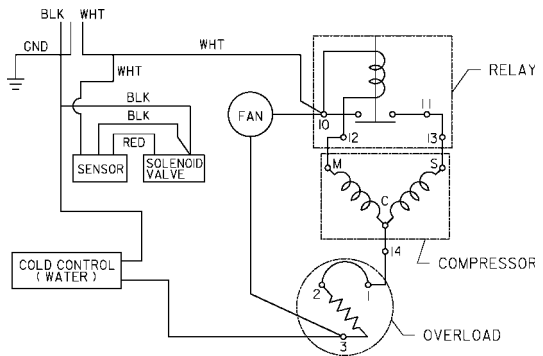

NOTE:
WHEN INSTALLING REPLACEMENT BUBBLER AND PEDESTAL, TIGHTEN NUT (ITEM 32) ONLY TO HOLD PARTS SNUG IN POSITION. DO NOT OVER TIGHTEN.

FIG. 4