

# Installation/Care/Use Manual

## SwirlFlo® Refrigerated Fountains with FLEXI-GUARD®

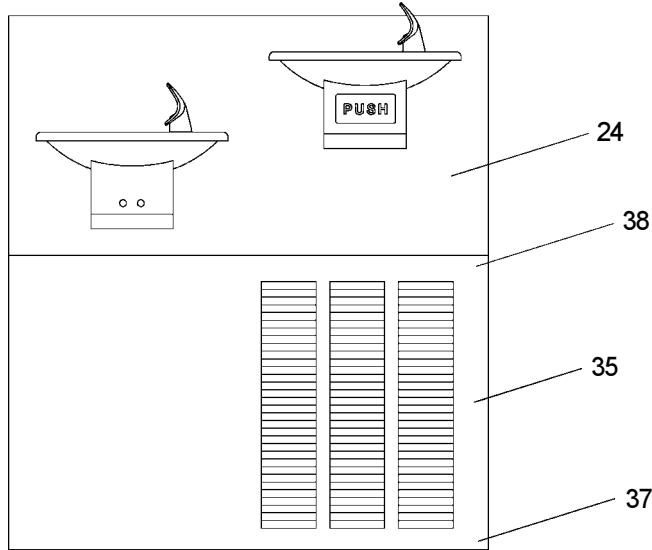

### Installer

To assure you install this model easily and correctly, PLEASE READ THESE SIMPLE INSTRUCTIONS BEFORE STARTING THE INSTALLATION. CHECK YOUR INSTALLATION FOR COMPLIANCE WITH PLUMBING, ELECTRICAL AND OTHER APPLICABLE CODES. After installation, leave these instructions inside the fountain for future reference.

### IMPORTANT

ALL SERVICE TO BE PERFORMED BY AN AUTHORIZED SERVICE PERSON

### IMPORTANT! INSTALLER PLEASE NOTE.

THE GROUNDING OF ELECTRICAL EQUIPMENT SUCH AS TELEPHONE, COMPUTERS, ETC. TO WATER LINES IS A COMMON PROCEDURE. THIS GROUNDING MAY BE IN THE BUILDING OR MAY OCCUR AWAY FROM THE BUILDING. THIS GROUNDING CAN CAUSE ELECTRICAL FEEDBACK INTO A FOUNTAIN, CREATING AN ELECTROLYSIS WHICH CAUSES A METALLIC TASTE OR AN INCREASE IN THE METAL CONTENT OF THE WATER. THIS CONDITION IS AVOIDABLE BY USING THE PROPER MATERIALS AS INDICATED. ANY DRAIN FITTINGS PROVIDED BY THE INSTALLER SHOULD BE MADE OF PLASTIC TO ELECTRICALLY ISOLATE THE FOUNTAIN FROM THE BUILDING PLUMBING SYSTEM.

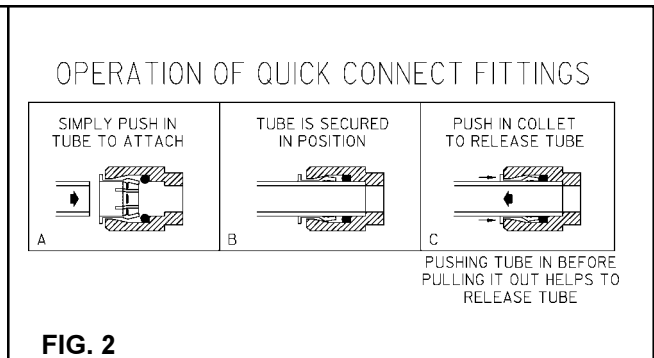
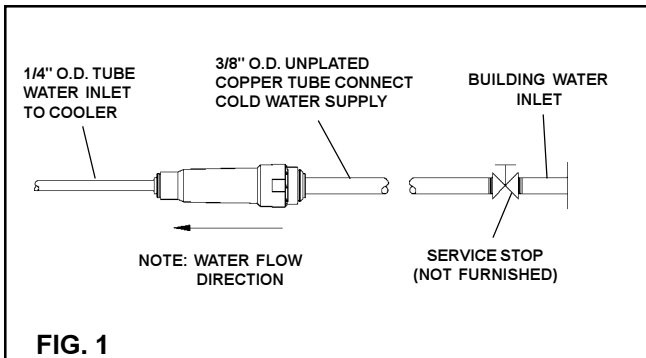

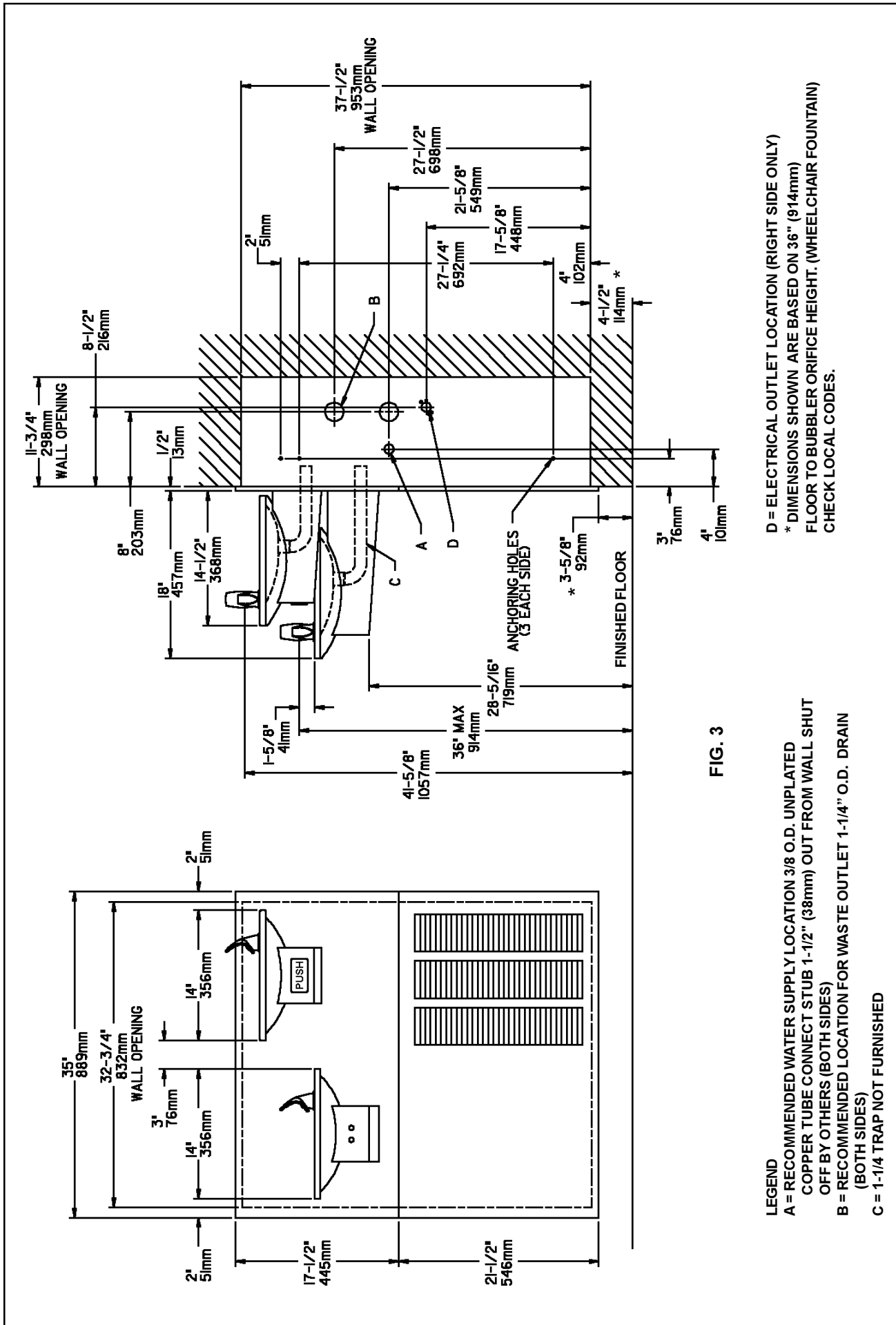

FIG. 3

- LEGEND**
- A = RECOMMENDED WATER SUPPLY LOCATION 3/8 O.D. UNPLATED COPPER TUBE CONNECT STUB 1-1/2" (38mm) OUT FROM WALL SHUT OFF BY OTHERS (BOTH SIDES)
  - B = RECOMMENDED LOCATION FOR WASTE OUTLET 1-1/4" O.D. DRAIN (BOTH SIDES)
  - C = 1-1/4 TRAP NOT FURNISHED

- D = ELECTRICAL OUTLET LOCATION (RIGHT SIDE ONLY)
- \* DIMENSIONS SHOWN ARE BASED ON 36" (914mm) FLOOR TO BUBBLER ORIFICE HEIGHT. (WHEELCHAIR FOUNTAIN) CHECK LOCAL CODES.

## INSTALLATION INSTRUCTIONS

1. **Fasten mounting box** into wall cutout using (6) screws or bolts (provided by others) through holes or knockouts provided on each side of the mounting box. See mounting box instructions and figure 3.
2. **Mount back panel** using (2) #8 x .50" (13mm) pan head screws and (2) large clips provided.
3. **Secure fountain body** through back panel to wall box using (4) 5/16" -18 x 1.75" (44mm) hex head bolts and (4) 5/16" - 18 nuts provided. (Typical each fountain).
4. **Attach solenoid valve assembly** to the mounting box. See figure 10.
5. **Place refrigeration package inside mounting box** and connect water outlet tube on refrigeration package to water in tube on regulator holder (item 10) with tubing and fitting provided. See figure 4.
6. **Water inlet is 3/8" O.D. and waste tube is 1-1/4" O.D.** (Both provided) 1-1/4" O.D. slip trap (provided by others).
7. **Connecting lines to be unplated copper and thoroughly flushed** to remove all foreign matter before connecting to refrigeration package. The furnished strainer (Item 54) should be added to the supply line.
8. **Connect refrigeration package to supply line** with a shut off valve and install a 3/8" unplated copper water line between the valve and the cooler. Remove burrs from outside of water line. Insert water line straight into fittings until they reach a positive stop, approximately 3/4" (19mm). (See Fig. 1 and 2) **DO NOT SOLDER TUBES INSERTED INTO THE STRAINER AS DAMAGE TO THE O-RINGS MAY RESULT.**
9. **Electrical: Insure power supply is identical in voltage, hertz, and phase** to that specified on the refrigeration package serial plate. Never wire compressor directly to the power supply.
10. **Turn water supply on** and check thoroughly for leaks.
11. **Release air from tank** by depressing push bar or activating sensor; a steady stream of water assures all air is removed.
12. **Re-check for leaks.**
13. **Stream height is factory set at 35 PSI.** If supply pressure varies greatly from this, turn adjustment screw on regulator (item 12). Clockwise adjustment will raise the stream height and counter-clockwise adjustment will lower stream height. For best adjustment, stream should hit basin approximately 6-1/2" from the bubbler.
14. **Rotate fan blade on refrigeration package** to insure proper clearance and free fan action.
15. **Connect power supply.**
16. **Replace access panel and install grill** using (4) #8 x 1.00" (25mm) PH screws and (4) small clips provided.

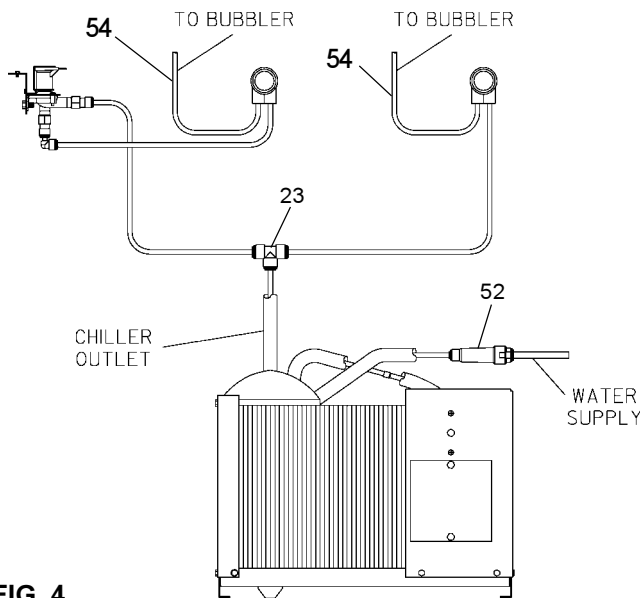

FIG. 4

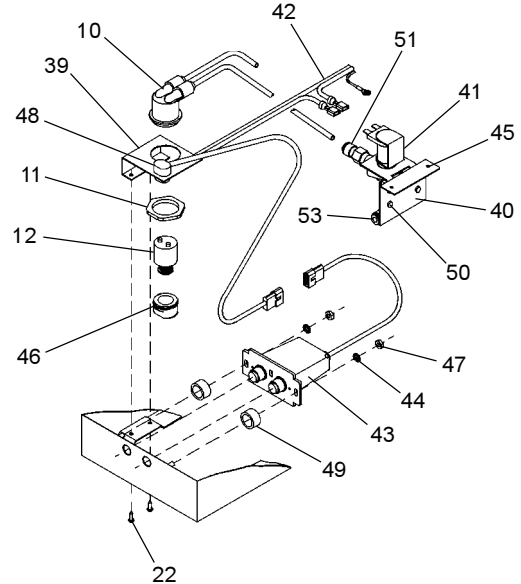

FIG. 5

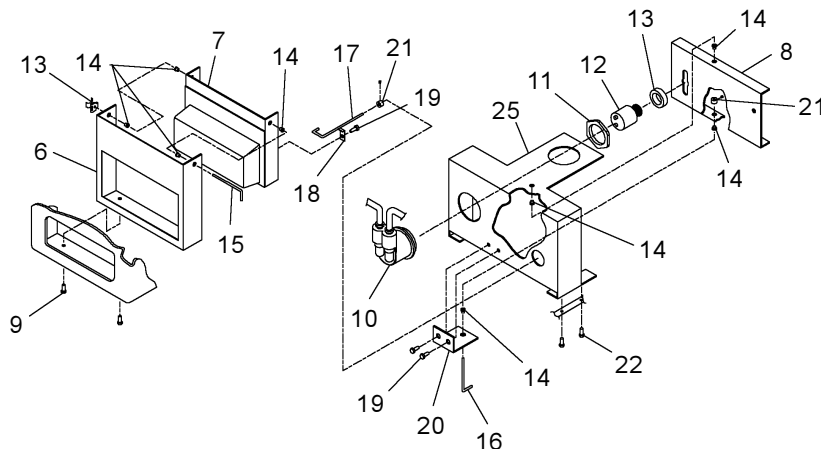
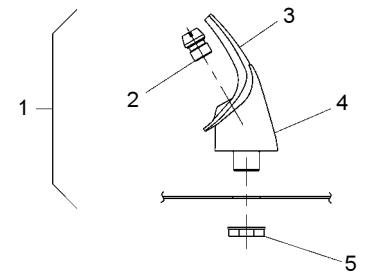

FIG. 6



**NOTE: WHEN INSTALLING REPLACEMENT BUBBLER AND PEDESTAL, TIGHTEN NUT (ITEM 5) ONLY TO HOLD PARTS SNUG IN POSITION. DO NOT OVER TIGHTEN.**

FIG. 7

PARTS LIST		
ITEM NO.	PARTNO.	DESCRIPTION
1	51349C	BUBBLER ASSY
	51350C	BUBBLER ASSY (BRONZETONE)
2	40322C	ORIFICE ASSY
	40086C	ORIFICE ASSY (BRONZETONE)
3	50934C	HOUSING ASSY
4	50168C	PEDESTAL
	50373C	PEDESTAL (BRONZETONE)
5	70012C	BUBBLER LOCKNUT
6	21804C	PUSH BAR MOUNTING BRACKET
7	21810C	PUSH BAR ASSY
	21833C	PUSH BAR ASSY (BRONZETONE)
8	21806C	REGULATOR ACTIVATOR ARM
9	70426C	SCREW - #8-32 X .25 THMS
10	50986C	HOLDER - REGULATOR
11	40045C	HEX NUT
12	61313C	REGULATOR
13	75555C	CLIP
14	50198C	BUSHING - NYLON
15	70410C	ROD - PIVOT
16	70425C	ROD - PIVOT
17	70378C	ROD - PUSH
18	21705C	CLIP - PUSH ROD
19	70002C	SCREW #10 X .50 HHSM
20	21844C	PIVOT ROD BRACKET
21	40206000	RETAINER
22	70208C	SCREW #10-24 X .37 PHTC
23	70682C	TEE - 1/4
24	55000943	BACK PANEL ASSY
	21840C	BACK PANEL ASSY (BRONZETONE)
25	21803C	REGULATOR MOUNTING BRACKET
26	45336C	STRAINER & FERRULE ASSY
	45337C	STRAINER & FERRULE ASSY (BRONZETONE)
27	50074C	GASKET - TAILPIPE
28	50377C	GASKET - TAILPIPE
29	45330C	WASTE ARM
30	55001026	BASIN SWIRLFLOW
	21827C	BASIN SWIRLFLOW (BRONZETONE)
31	21822C	FTN BODY & SHELL-SHORT
	21831C	FTN BODY & SHELL-SHORT (BRONZETONE)
32	22535C	FTN BODY & SHELL-LONG
	22536C	FTN BODY & SHELL-LONG (BRONZETONE)
33	21845C	COVER PLATE-SHORT
	21835C	COVER PLATE-SHORT (BRONZETONE)
34	21846C	COVER PLATE-LONG
	21836C	COVER PLATE-LONG (BRONZETONE)
35	EG9	GRILL
	EG9B	GRILL (BRONZETONE)
36	70055C	SPEED NUT
37	74070032	SPEED NUT #8
38	74130045	CLIP - TINNEMAN
39	22525C	REGULATOR MOUNTING BRACKET
40	22526C	SOLENOID MOUNTING BRACKET
41	31272C	SOLENOID VALVE ASSY
42	31376C	POWER CORD
43	31384C	SENSOR ASSY
44	34783003	WASHER - STAR #10
45	38417001	SCREW - #8-18 X .37 HHSM
46	56082C	NUT - REGULATOR
47	70016C	HEX NUT #10-32
48	50203C	STRAIN RELIEF
49	51409C	SPACER - 1/2 X .44
50	70256C	SCREW - 1/4-20 X .38 HHTC
51	75507C	FITTING - 1/4 NPTF X 1/4 O.D.
52	55996C	STRAINER
53	70817C	ELBOW 1/4 X 1/4
54	56092C	Poly Tubing 48" (Cut to Length)

**TROUBLE SHOOTING AND MAINTENANCE**

- Orifice Assy:** Minerals deposits on orifice can cause water flow to spurt or not regulate. Mineral deposits may be removed from the orifice with a small round file not over 1/8" diameter or a small diameter wire. **CAUTION:** Do not file or cut orifice materials.
- Stream Regulator:** If orifice is free of material deposits regulate water flow according to instructions on page 3.
- CAUTION:** Cleaning of Bronzestone Models requires special care. Outer surfaces must be cleaned with a mild detergent or mixture of vinegar and water only, rinsed and wiped dry. Abrasive and acidic cleaners may eventually damage the Bronzestone finish.
- Sensor Control:** The sensor has a 2 second delay time. If sensor fails to operate valve mechanism or operates erratically, check the following:
  - Ensure there are no obstructions within a 40 inch radius from the front of fountain.
  - Check wire connections at the solenoid valve and at the sensor. **CAUTION:** Make sure unit is unplugged before checking any wiring.
  - Ensure proper operation of solenoid valve. If there is an audible clicking sound yet no water flows, look for an obstruction in the valve itself or elsewhere in the water supply line. **WARNING:** Do not expose sensor to direct sunlight.
- Sensor Range Adjustment:** The electronic sensor used in this fountain is factory pre-set for a "visual" range of 36 inches. If actual range varies greatly from this, or a different setting is desired, follow the range adjustment procedure below:
  - Remove bottom cover of fountain.
  - Remove sensor by removing washers and nuts that secure sensor on studs.
  - Locate range adjustment screw between the red lenses of the sensor, then with a small tip screwdriver, rotate the range adjusting screw clockwise to increase range or counter-clockwise to decrease range. 1/4 turn of screw is equal to approximately 12 - 18 inches of range. **CAUTION:** Complete range of sensor (24 - 48 inches) is only one turn of the adjusting screw.
  - Remount sensor on studs and replace bottom cover.

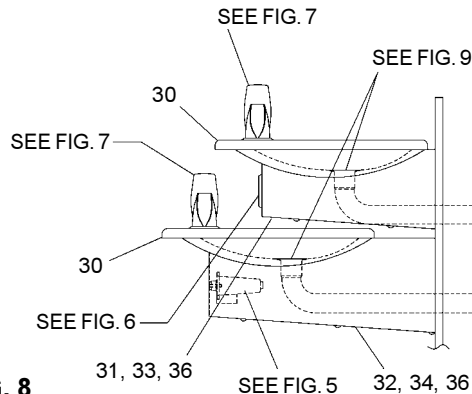

**FIG. 8**

**FIG. 10**

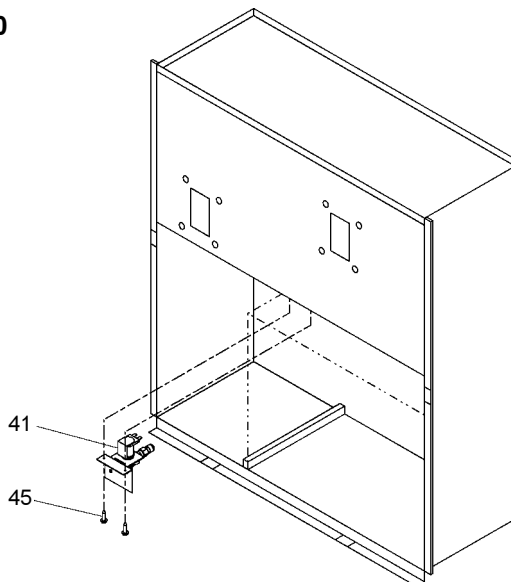

**FIG. 9**

