

ELKAY With FLEXI-GUARD[™]
INSTALLATION, CARE & USE MANUAL

SWIRLFLO[™] Refrigerated fountains with FLEXI-GUARD[™]



INSTALLER

⚠ CAUTION: Review these instructions before beginning installation. Be sure that installation conforms to all plumbing, electrical and other applicable codes.

⚠ WARNING: When installation is complete, ensure these instructions are left with building owner for future reference.

⚠ WARNING: Service to be performed by authorized service personnel only.

NOTE: It is common practice to ground electrical hardware such as telephones, computers and other devices to available water lines. This can, however, cause electrical feedback in the plumbing circuit, which results in an “electrolysis” effect occurring in the fountain. This may result in water which has a metallic taste to it or has a noticeable increase in the metallic content of the water.

When inspecting plumbing circuit, remember the line may be grounded some distance from the installation, and may occur outside the building or area in which the unit is being installed.

This condition can be avoided (in most cases) by using recommended materials during installation. Any drain fittings provided by the installer should be made of **plastic** which will electronically isolate the fountain from the remainder of the building’s plumbing circuits.

Model ENOBM8C

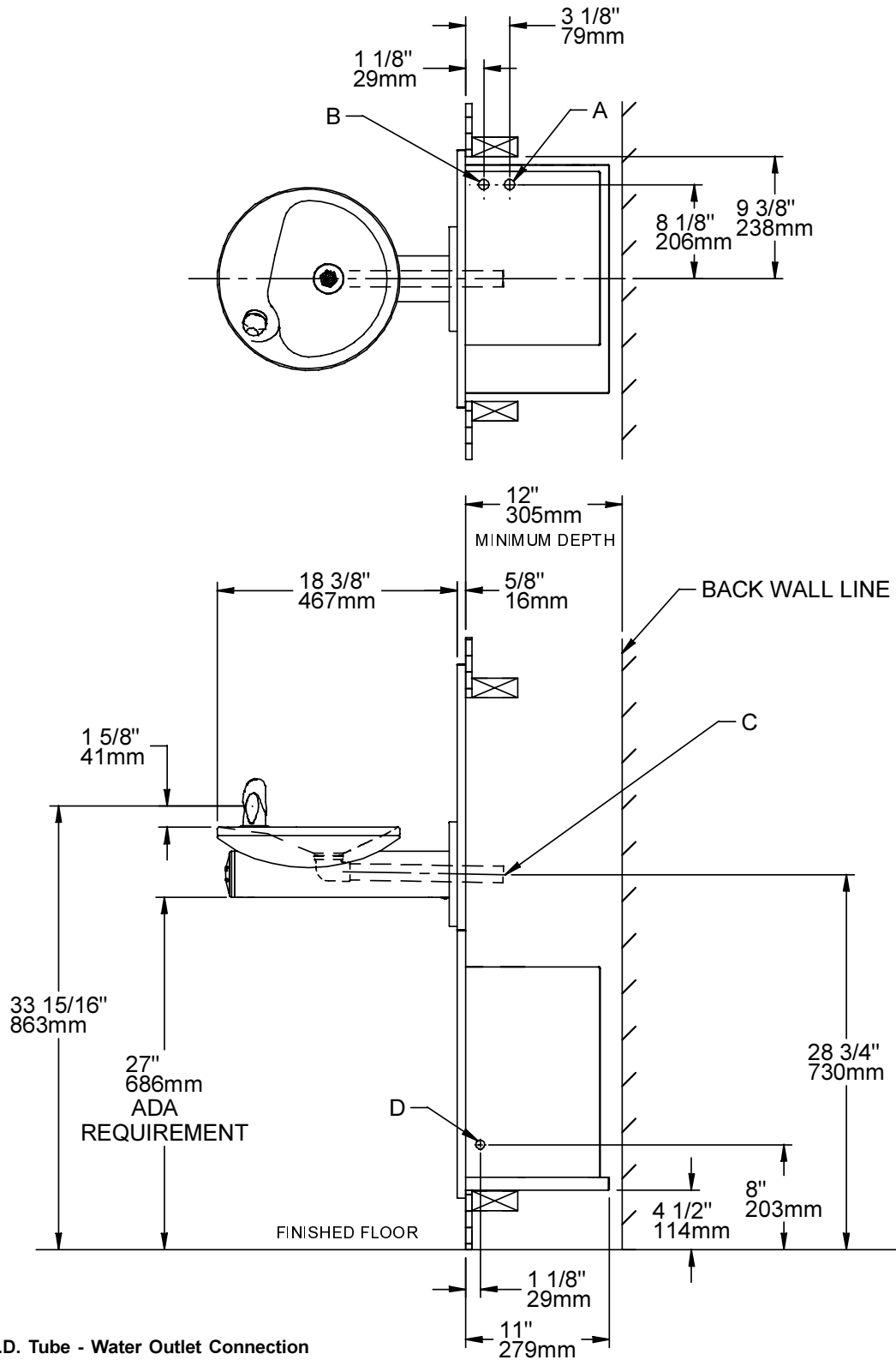

- LEGEND**
- A = 1/4" O.D. Tube - Water Outlet Connection
 - B = 3/8" O.D. Tube - Water Inlet Connection
 - C = 1-1/4" Waste Tube
 - D = ELECTRICAL INLET

Figure 1 - Rough-in Dimensions



Figure 2 - Chiller Installation

REQUIRED TOOLS AND MATERIALS

These tables show special tools and/or additional materials (not provided) which are necessary to complete installation of these units:

Special Tools

Item	Description	Quantity
	NONE	

Additional Materials

Item	Description	Quantity
1	Unplated copper inlet pipe	
2	Service Stop	

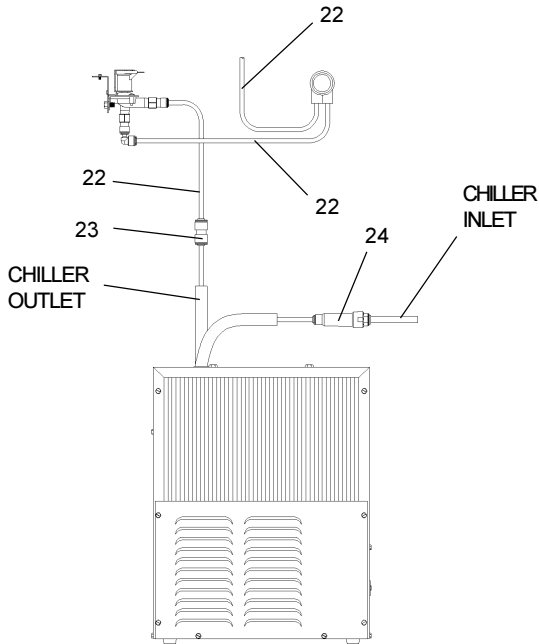

Figure 3 - ENO Tube Routing

1. **Install chiller:** Remove front panel of chiller. Slide chiller onto the shelf and position it to the left as per dimensions in Figure 1.

Note: Building construction must allow for adequate air flow on both sides, top and back of chiller. A minimum of 4" (102mm) on both sides and top is required. See chiller installation for additional instructions.

2. **Attach solenoid valve assembly to the underside of cross member of mounting frame on electronic sensor unit.** (See Fig. 7).
3. **Make water supply connections.** Inlet port is marked on the chiller (1/4" O.D. copper tube). Bend the copper tube (provided) at an appropriate length from the chiller to opening in frame. Install the in-line strainer (provided with chiller) by pushing it in until it reaches a positive stop, approximately 3/4" (19mm) on the marked chiller inlet port (See Figs. 3) (Refer to Fig. 12 on page 7 for details on assembling quick connect fittings). Attach an unplated and deburred copper water inlet line and a service stop (not provided) to the chiller. Turn on the water supply and flush the line thoroughly.

Caution: **DO NOT SOLDER** tubes inserted into the strainer as damage to o-rings may result.

4. **Make connection between remote chiller outlet tube and solenoid valve assembly.** Outlet port is marked on the chiller (1/4" O.D. copper tube). Install a 1/4" union (provided) on the marked chiller outlet port. Insert one end of 1/4" poly tubing into the union and the other end into the straight fitting on the solenoid valve assy (See Fig. 3)
5. **Hang the upper panel on the mounting frame hanger.** Be sure that the panel is engaged with hanger at the top of frame before releasing it. Align holes in the panel with holes in the mounting frame. Install two (2) #10-24 x 5/8" (16mm) screws (Item 27 - Figure 4) in holes and tighten securely.

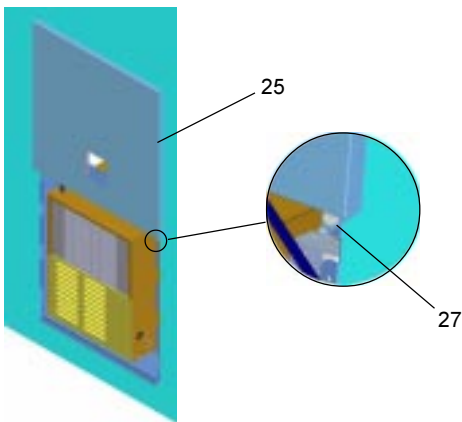
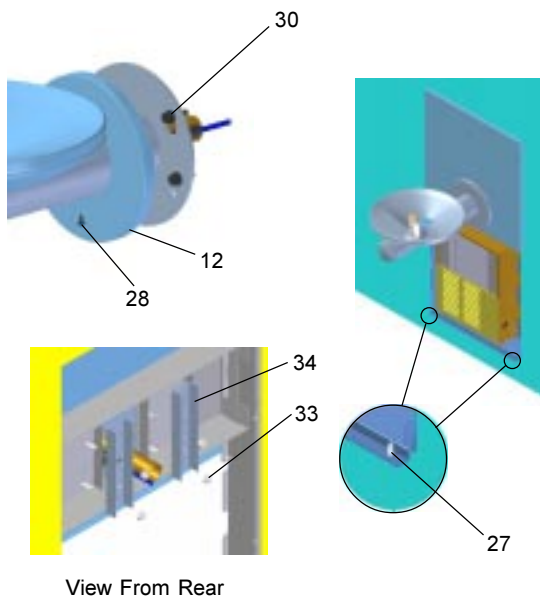

Figure 4 - Upper Panel Installation



View From Rear

Figure 5 - Fountain Installation

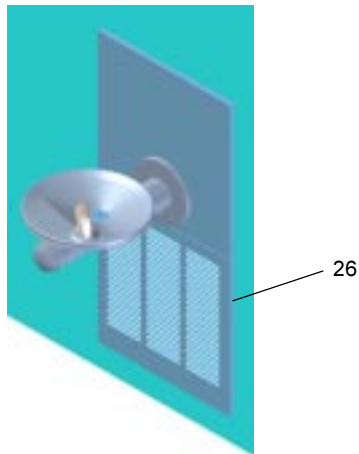

Figure 6 - Lower Panel Installation

6. **Install the fountain.** Remove the screw (Item 28) from cover plate (Item 12) and slide cover plate toward basin. Mount the fountain to the upper panel and frame with (4) 5/16" x 1" (25mm) long bolts (Item 30), bracket (Item 34) and nuts (Item 33) provided. Tighten securely. **Brackets (Item 34) must be installed as shown to properly support fountain.** (See Figure 5)
 7. **Attach waste tube** (1-1/4" O.D.) to 1-1/4" O.D. slip trap (provided by others).
 8. **Connect the fountain drain waste tube to the building sanitary sewer system.** Connection should be made in compliance with local plumbing code requirements. (Note: Plumbing trap is not included with the fountain).
 9. **Make connection between solenoid valve assembly and fountain(s).** Insert the 1/4" poly tubing coming from the fountain with sensor into the solenoid valve. (See Fig. 3)
 10. **Connect power cord of sensor to solenoid valve assembly by running it through the back panel and connecting it to terminal shown in Fig. 8.**
 11. **Turn on water supply and check for leaks.** Release air from tank by interrupting infrared beam; a steady stream of water assures all air is removed. The sensor has a 30 second maximum **ON** time. It may be necessary to step away from beam a few times to allow chiller tank to fill.
- ⚠ CAUTION: DO NOT SOLDER tubes while inserted into the strainer as damage to o-rings may result.**
12. **These products are designed to operate on 20-105 PSIG supply line pressure.** If inlet pressure is above 105 PSIG, a pressure regulator must be installed in the supply line.
- ⚠ CAUTION: Any damage caused by connecting these products to a supply line with pressure lower than 20 PSIG or higher than 105 PSIG IS NOT covered under warranty.**
13. **Make electrical connections to the chiller.** See chiller instructions.
 14. **Check stream height from bubbler.** Stream height is factory set at 35-40 PSI. If supply pressure varies greatly from this, please do the following. For **Electronic sensor units only**, remove lower panel (Item 26 - Fig. 6) and turn adjustment screw on the regulator (Item 17 - Fig. 8). Clockwise adjustment will raise stream height and counterclockwise movement will lower stream height. For best adjustment stream should hit basin approximately 6-1/2" from the bubbler.
 15. **Mount lower panel.** Loosen the two (2) #10-24 x 5/8" (16mm) screws (Item 27 - Figure 5) at frame bottom lip. Slide upper tongue of lower panel (Item 26 - Figure 6) under lower edge of already installed upper panel. Tighten previously loosened screws securely. (See Figure 6)

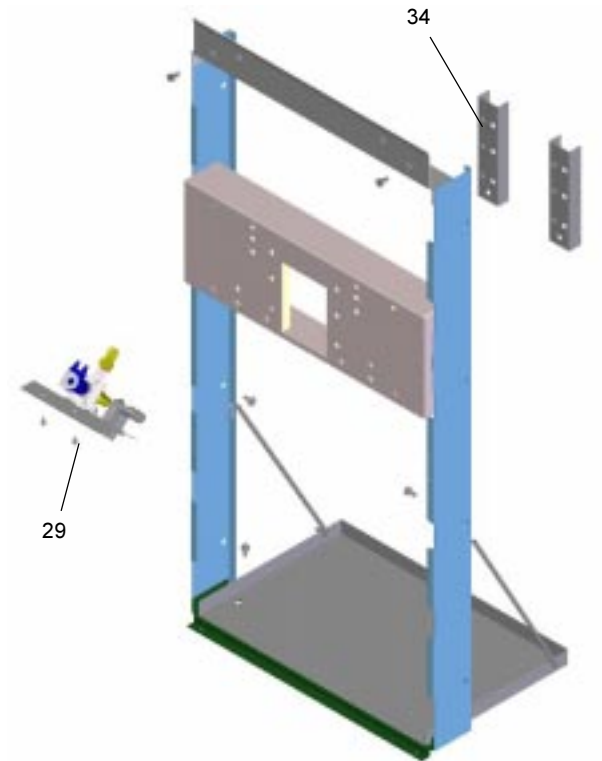

Figure 7 - Solenoid Assembly

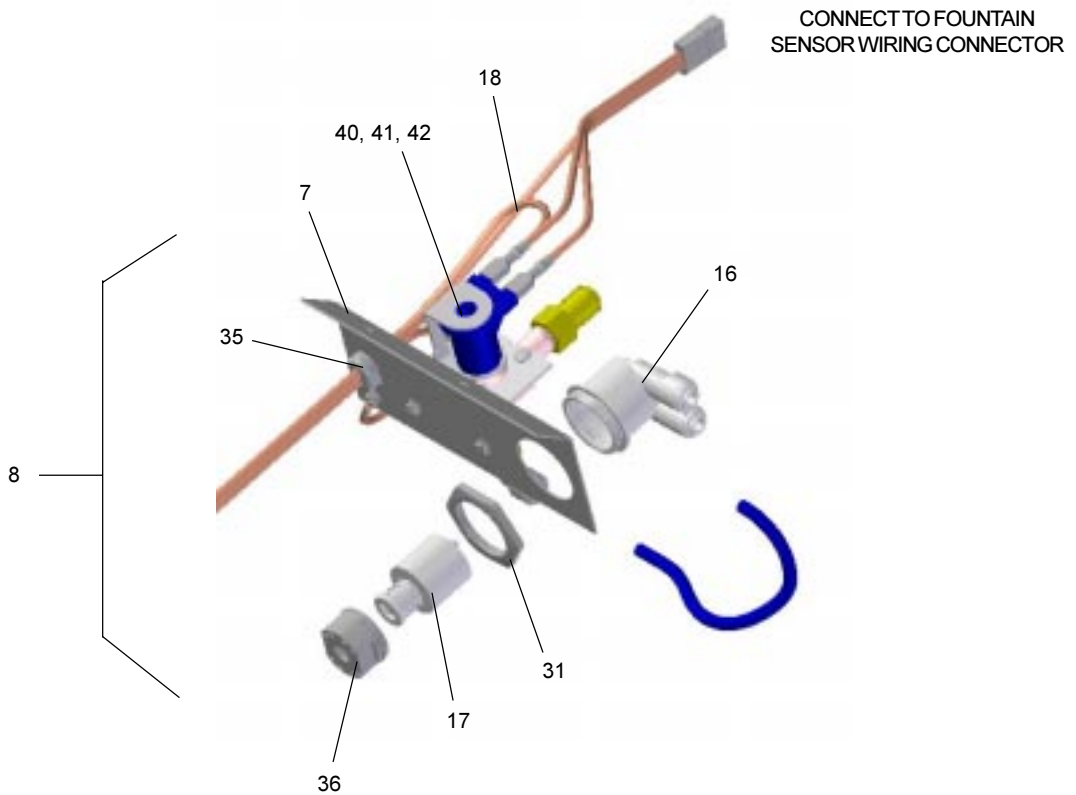

Figure 8 - Regulator Assembly

ENOB8C

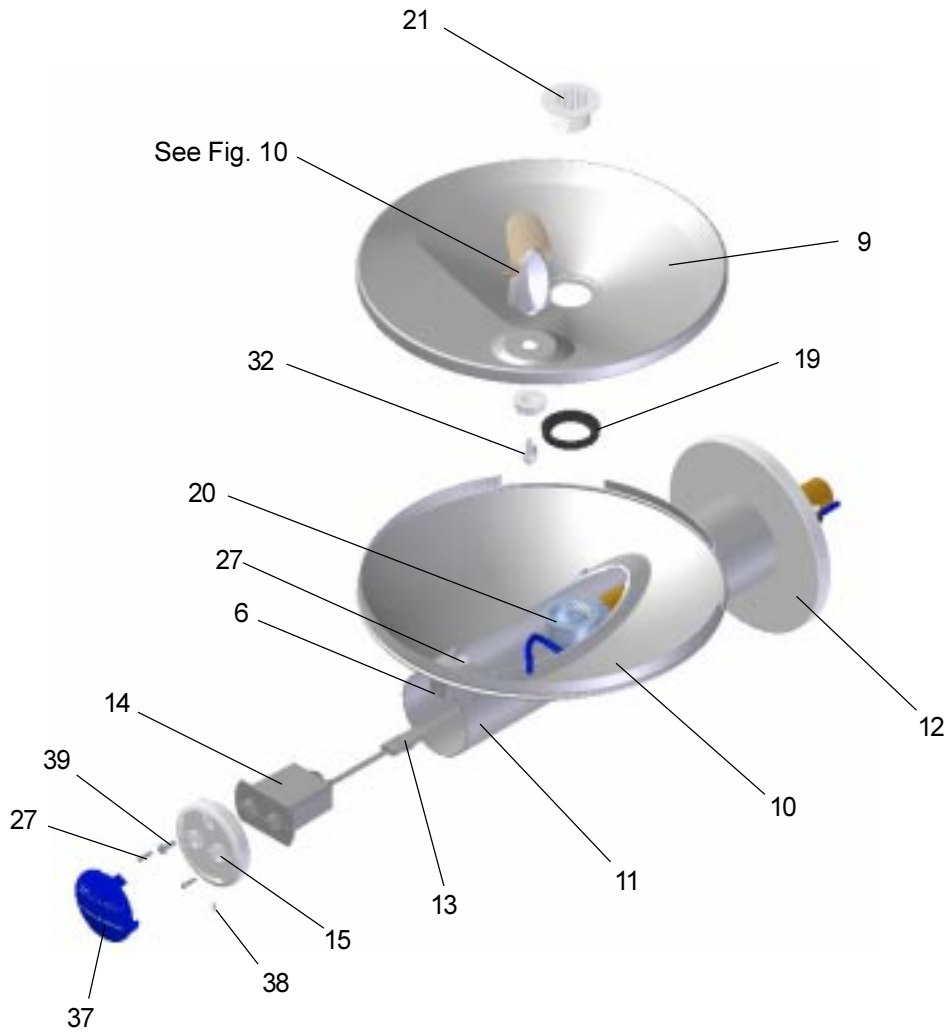
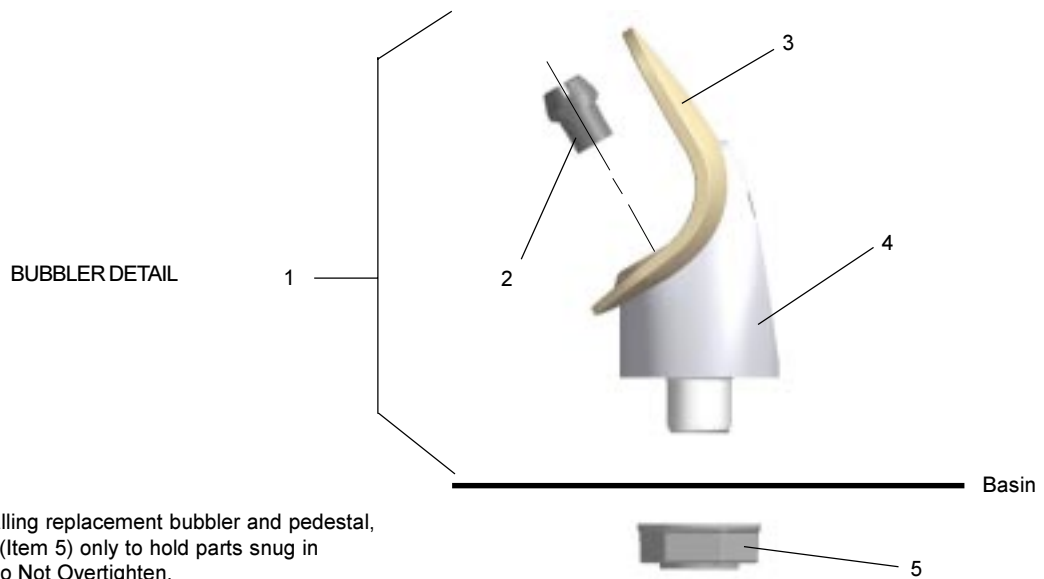

Figure 9 - Exploded View



NOTE:
When installing replacement bubbler and pedestal, tighten nut (Item 5) only to hold parts snug in position. Do Not Overtighten.

Figure 10 - Bubbler Assembly

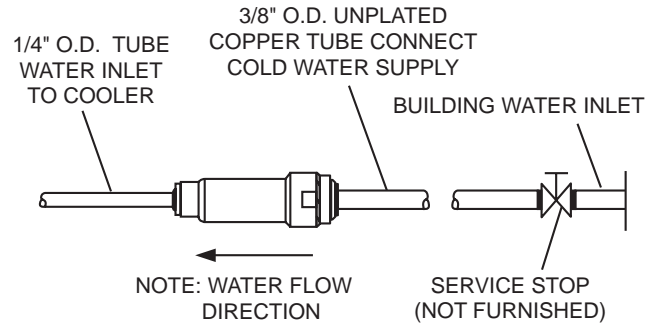
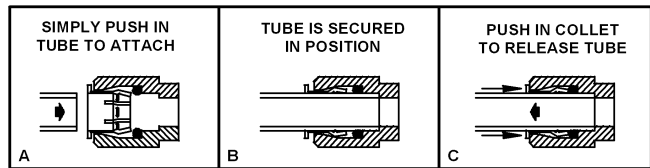

Figure 11 – Water Supply Connections

Actuation of Quick Connect Water Fittings: Cooler is provided with lead-free connectors which utilize an o-ring water seal. To remove tubing from the fitting, relieve water pressure, push in on the gray collar while pulling on the tubing. (See Figure 12) To insert tubing, push tube straight into fitting until it reaches a positive stop (approximately 3/4").

OPERATION OF QUICK CONNECT FITTINGS



PUSHING TUBE IN BEFORE
PULLING IT OUT HELPS TO
RELEASE TUBE

Figure 12 – Quick Connect Fittings

Installation Package

The components for installation are packed in three separate boxes, regardless of the type of unit being installed. The boxes contain the following:

Box No. 1: Wall Frame(s)

Box No. 2: Remote Chiller, ECH8

Box No. 3: Fountain Arm and Panels

Additional materials, as noted in the Parts List, are also shipped in these boxes.

PARTS LIST		
ITEM NO.	PART NO.	DESCRIPTION
1	56073C	Bubbler Assy
2	40322C	Assy -Orifice
3	56011C	Housing Assembly
4	55997C	Pedestal
5	75580C	Bubbler Locknut
6	15027C	Brkt - Swirlflow
7	28454C	Brkt - Solenoid/Reg/Wire
8	28455C	Assy - Brkt Solenoid/Reg/Wire
9	28474C	Basin - Swirlflow
10	28473C	Lower Shell
11	45767C	Fountain Body
12	28343C	Cover Plate
13	36207C	Wire - Extension
14	36193C	Assy - Sensor Eye
15	45813C	Sleeve - Swirlflow EE
16	50986C	Holder - Regulator
17	61315C	Regulator
18	31376C	Cord - Power 115v
19	56163C	Gasket - Drain
20	45769C	Assy - Drain/Tailpipe
21	45768C	Drain - Plug 1-1/2"
22	56092C	Poly Tubing (Cut To Length)
23	70683C	Fitting - Union 1/4 x 1/4
24	55996C	Strainer (Provided With Chiller)
25	28382C	Back Panel
26	26833C	Lower Panel
27	111008343890	Screw - #10-24 x .62 HHMS
28	70432C	Screw - #8-32 x .38 THTC
29	38417001	Screw - #8-18 x .37 HHSM
30	75560C	Screw - 5/16-18 x 1.00 HHMS
31	40045C	Nut - Hex 1 5/16
32	70817C	Fttnng - Elbow 1/4 x 1/4
33	70020C	Nut - Hex 5/16-18
34	28395C	Bracket - Support
35	50203C	Bushing - Strain Relief
36	56082C	Nut - Regulator
37	56204C	Lens - Swirlflow EE
38	70022C	Screw - #6-32 x .31 Set
39	70644C	Screw - #6-32 x .50 PHMS
40	31272C	Solenoid Valve
41	70817C	Fttnng-Elbow 1/4 Stem x 1/4x90
42	75507C	Fttnng-1/4 NPTF x 1/4OD

TROUBLE SHOOTING AND MAINTENANCE

- Orifice Assy:** Minerals deposits on orifice can cause water flow to spurt or not regulate. Mineral deposits may be removed from the orifice with a small round file not over 1/8" diameter or a small diameter wire. **CAUTION:** Do not file or cut orifice materials.
 - Stream Regulator:** If orifice is free of material deposits regulate water flow according to instructions on page 4.
 - Sensor Control:** The sensor has a 2 second delay time. If sensor fails to operate valve mechanism or operates erratically, check the following:
 - Ensure there are no obstructions within a 40 inch radius from the front of fountain.
 - Check wire connections at the solenoid valve and at the sensor. **CAUTION:** Make sure unit is unplugged before checking any wiring.
 - Ensure proper operation of solenoid valve. If there is an audible clicking sound yet no water flows, look for an obstruction in the valve itself or elsewhere in the water supply line. **WARNING:** Do not expose sensor to direct sunlight.
 - Sensor Range Adjustment:** The electronic sensor used in this fountain is factory pre-set for a "visual" range of 36 inches. If actual range varies greatly from this, or a different setting is desired, follow the range adjustment procedure below:
 - Remove front lens.
 - Locate range adjustment screw between the lenses of the sensor, then with a small tip screwdriver, rotate the range adjusting screw clockwise to increase range or counter-clockwise to decrease range. 1/4 turn of screw is equal to approximately 12 - 18 inches of range. **CAUTION:** Complete range of sensor (24 - 46 inches) is only one turn of the adjusting screw.
- c) Replace Lens.

CARE AND CLEANING INSTRUCTIONS

DO NOT use abrasive or chemical cleaners to clean the sensor lens. They may dull the luster and attack the plastic cover and chrome finish of the fountain. Use **ONLY** soap and water, then wipe with clean cloth or towel. When cleaning adjacent surfaces, the fountain and the sensor lens should be protected from any splattering of cleaners. Acid and cleaning fluids can discolor and damage chrome plating and plastic sensor lens.