

# With FLEXI-GUARD®

## Installation/Care/Use Manual

### USES HFC-134A REFRIGERANT

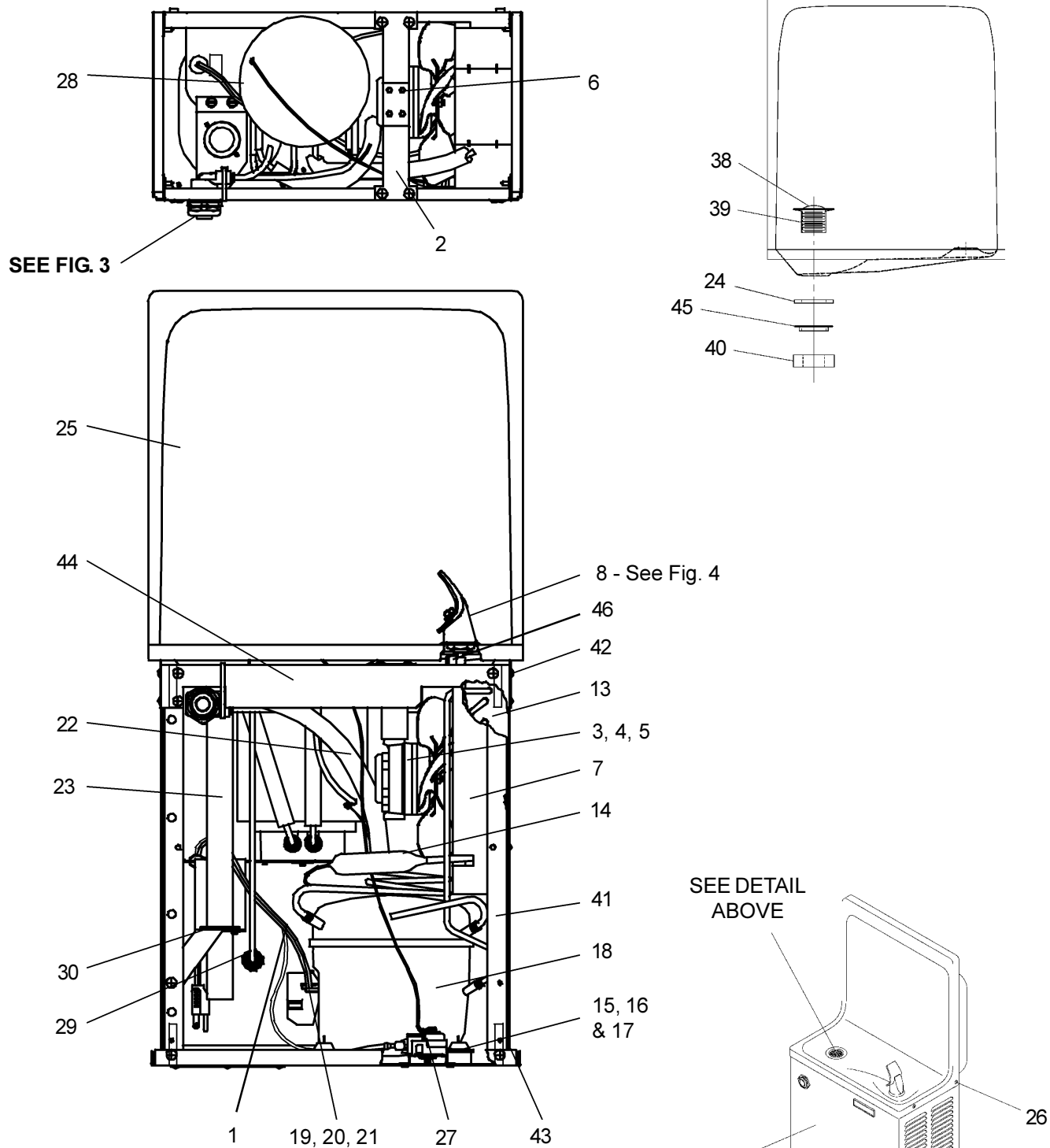
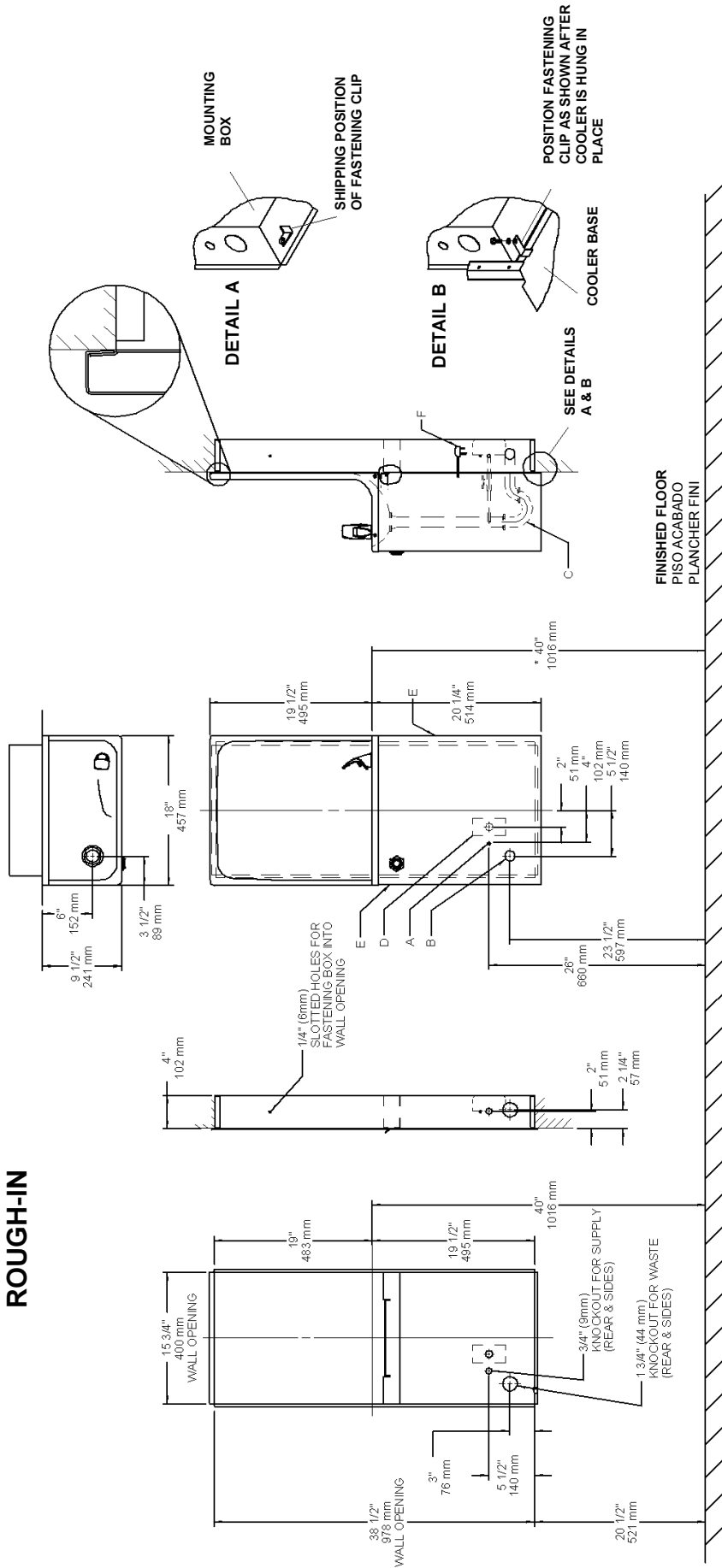

FIG. 1

**MOUNTING BOX  
ROUGH-IN**



**FIG. 2**

**LEGEND/LEYENDA/LÉGENDE**

**A = RECOMMENDED WATER SUPPLY LOCATION 3/8" O.D. UNPLATED COPPER TUBE CONNECT STUB 1-1/2 IN. (38 mm) OUT FROM WALL SHUT OFF BY OTHERS**  
 SE RECOMIENDA UBICAR EL TUBO CORTO DE CONEXIÓN AL TUBO DE COBRE SIN CHAPAR DE 3/8" DE DIÁM. EXT. A 1-1/2" (38 mm) FUERA DE LA LLAVE DE PASO EN LA PARED COLOCADA POR TERCEROS.  
 EMPACEMENT RECOMMANDÉ D'ALIMENTATION EN EAU PAR TUBE EN CUIVRE NON PLAQUÉ DE 3/8 PO. (9.5 mm) D. E. CONNECTANT UNE TUYAUTERIE DE 1-1/2 PO. (38 mm) DEPUIS LE ROBINET D'ARRÊT FOURNI PAR D'AUTRES.

**B = RECOMMENDED LOCATION FOR WASTE OUTLET 1-1/4" O.D. DRAIN**  
 UBICACIÓN RECOMENDADA PARA EL DRENAJE DE SALIDA DE AGUA DE 1 1/4" DE DIÁMETRO.  
 EMPACEMENT RECOMMANDÉ POUR LE DRAIN DE D.E. 1-1/4" DE SORTIE D'EAU.  
 PURGADOR DE 1 1/4" NO PROPORCIONADO\*\*  
 SIPHON 1-1/4" NON FOURNI\*\*

**D = ELECTRICAL OUTLET LOCATION**  
 UBICACIÓN DE LA TOMA DE ELECTRICIDAD  
 EMPACEMENT DE LA PRISE DE COURANT

**E = INSURE PROPER VENTILATION BY MAINTAINING 4" (102mm) (MIN.) CLEARANCE FROM CABINET LOUVERS TO WALL.**  
 ASEGURE UNA VENTILACIÓN ADECUADA MANTENIENDO UN ESPACIO E 4" (102mm) (MIN.) DE HOLSURA ENTRE LA REJILLA DE VENTILACIÓN DEL MUEBLE Y LA PARED  
 ASSUREZ-VOUS UNE BONNE VENTILATION EN GARDANT 4" (102mm) (MIN.) ENTRE LES ÉVÉNENTS DE L'ENCEINTE ET LE MUR.  
**F = POWER CORD 1-1/2 FEET (457mm) LONG**  
 CORDON D'ALIMENTATION 1-1/2' (457mm)

\* **RECOMMENDED HEIGHT FOR ADULTS.**  
 \* **DECREASE HEIGHT FOR CHILDREN.**  
 \* **ALTURA RECOMENDADA PARA ADULTOS.**  
 \* **REDUZCA PARA LOS NIÑOS.**  
 \* **HAUTEUR RECOMMANDÉE POUR LES ADULTES.**  
 \* **INSTALLEZ PLUS BAS POUR LES ENFANTS.**

**IMPORTANT**  
**ALL SERVICE TO BE PERFORMED BY AN AUTHORIZED SERVICE PERSON**

**INSTALLATION OF COOLER AND TRAP**

- 1) Hang the unit from the mounting box by placing tabs from the upper backside of the basin over top of the upper flange on the mounting box, and mount trap, as shown in Figure 2.

**NOTE:** Mounting box and trap **MUST** be supported securely. Add fixture support carrier if wall will not provide adequate support.  
**IMPORTANT:**

- 2) Secure cooler in place by positioning fastening clips as shown in Figure 2 - Detail B.
- 3) Install straight valve for 3/8 in. O.D. unplated copper tube.
- 4) Remove the access panel on the underside of the cooler and set it aside.
- 5) Connect water inlet line--See Note 4 of General Instructions.
- 6) Remove the slip nut and gasket from the trap and install them on the cooler waste line making sure that the end of the waste line fits into the trap. Assemble the slip nut and gasket to the trap and tighten securely.

**START UP**

**Also See General Instructions**

- 8) Replace the front panel and secure by retightening all screws.

Stream height is factory set at 35 PSI. If supply pressure varies greatly from this, remove items 31 and 32 and adjust screw on item 34. Clockwise adjustment will raise stream and counter-clockwise adjustment will lower stream. For best adjustment, stream should hit basin approximately 6-1/2" (165mm) from bubbler.

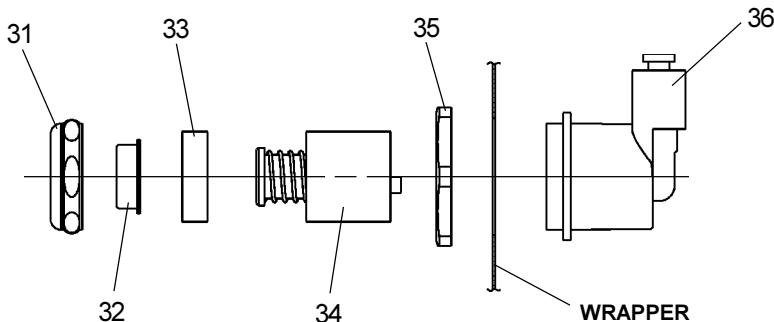

**FIG. 3**

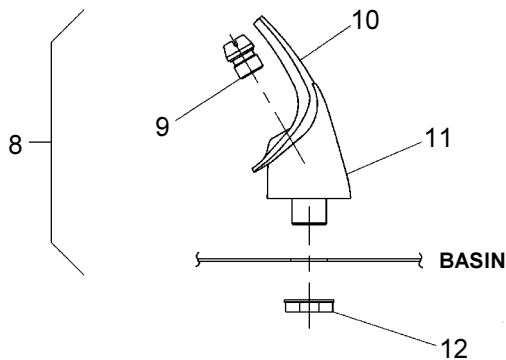

**NOTE:**  
 WHEN INSTALLING REPLACEMENT BUBBLER  
 AND PEDESTAL, TIGHTEN NUT (ITEM 12) ONLY  
 TO HOLD PARTS SNUG IN POSITION.  
 DO NOT OVER TIGHTEN.

**FIG. 4**

PARTS LIST

ITEM NO.	PART NO.	DESCRIPTION
1	31517C	Power Cord
2	27321C	Fan Bracket
3	30699C	Fan Blade
4	70018C	Hex Nut - Fan Blade
5	31490C	Fan Motor
6	70009C	Screw (Fan Motor)
7	50186C	Shroud - Fan
8	56073C	Bubbler Assy
9	40322C	Orifice Assy
10	56011C	Housing Assy
11	55997C	Pedestal
12	75580C	Locknut
13	62152C	Condenser
14	66202C	Drier
15	50144C	Grommet - Compressor Mtg.
16	70184C	Hair Pin - Cotter
17	70418C	Washer
18*	36094C	Compressor Serv. Pak EMI 70 HNR
19	36158C	Overload
20	35768C	Cover - Relay
21	35959C	Relay
22	66501C	Heat Exchanger
23	40041C	Tailpipe Assy (8 Gal)
	40429C	Precooler Assy (13 Gal)
24	50074C	Tailpipe Gasket
25	20593C	Basin - Stainless Steel
	20594C	Basin - Glass Filler
26	70208C	Screw - Basin Mtg.
27	31513C	Cold Control
28	66505C	Evaporator Assembly (8 Gal)
29	55996C	Strainer
30	27239C	Bracket - Precooler
31	40089C	Cover
32	40048C	Button
33	15005C	Retaining Nut
34	61313C	Regulator
35	40169C	Hex Nut
36	50986C	Regulator Holder
37	See Color Table	Wrapper
38	40038C	Strainer - Beehive
39	40619C	Ferrule - Tailpipe
40	50105C	Tailpipe Gasket
41	27093C	Angle-Front Corner
42	27292C	Bracket-Basin Mounting
43	27331C	Frame-Back/Bottom
44	27094C	Bracket-Front
45	40043C	Locknut
46	70817C	Fitting - Elbow 1/4 Stem
47	15009C	Nipple - Bubbler (GF)
48	100322740560	Gasket
49	31525028	O-Ring
50	40493C	Glass Filler
NS	56092C	Poly Tubing (Cut to length)

220V 60Hz

ITEM NO.	PART NO.	DESCRIPTION
1	35827C	Power Cord
5	31431C	Fan Motor
18*	36092C	Compressor Serv. Pak
19	36174C	Overload
21	36050C	Relay
22	66223C	Heat Exchanger
-	35826C	Power - Inlet

COLOR TABLE

PANEL COLOR	Item No. 37 Part No.
Gray Beige	21017C
Almond	21481C
Stainless Steel	21013C
Sandalwood	21480C
Granite	27208C
Light Gray	27209C

\*INCLUDES RELAY & OVERLOAD. IF UNDER WARRANTY, REPLACE WITH SAME COMPRESSOR USED IN ORIGINAL ASSEMBLY.

NOTE: All correspondence pertaining to any of the above water coolers or orders for repair parts MUST include Model No. and Serial No. of cooler, name and part number of replacement part.

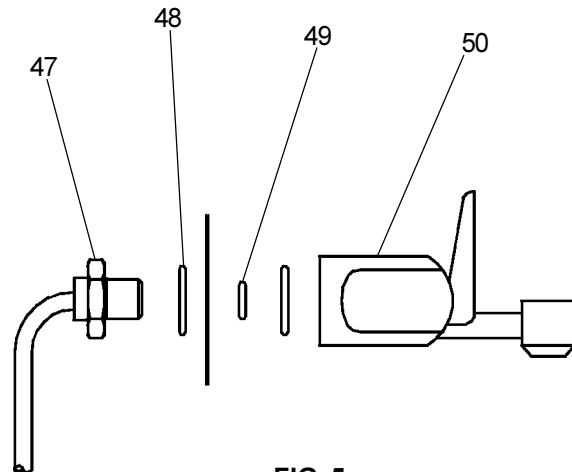

FIG. 5