

With FLEXI-GUARD®

# Installation/Care/Use Manual

USES HFC-134A REFRIGERANT

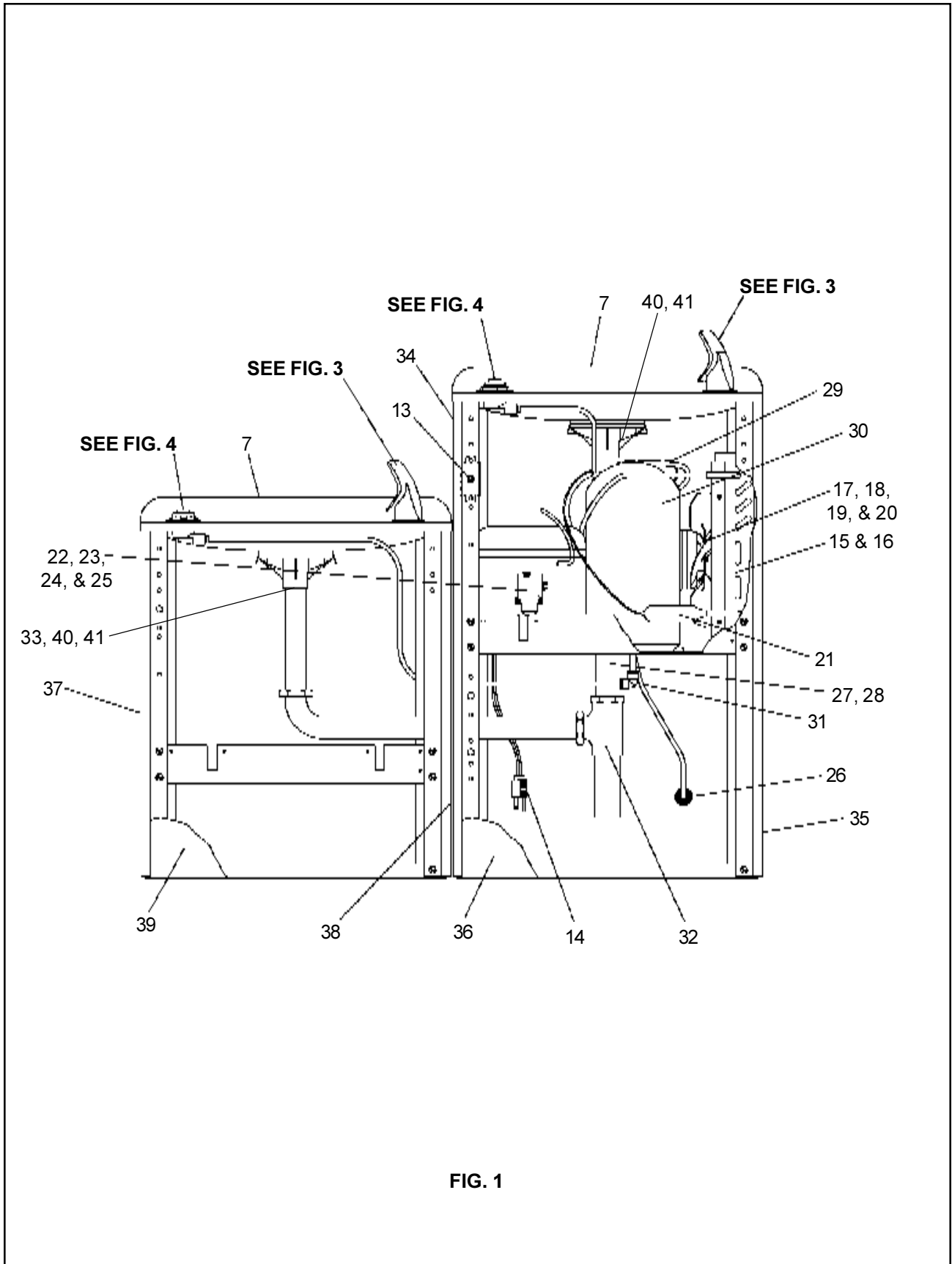

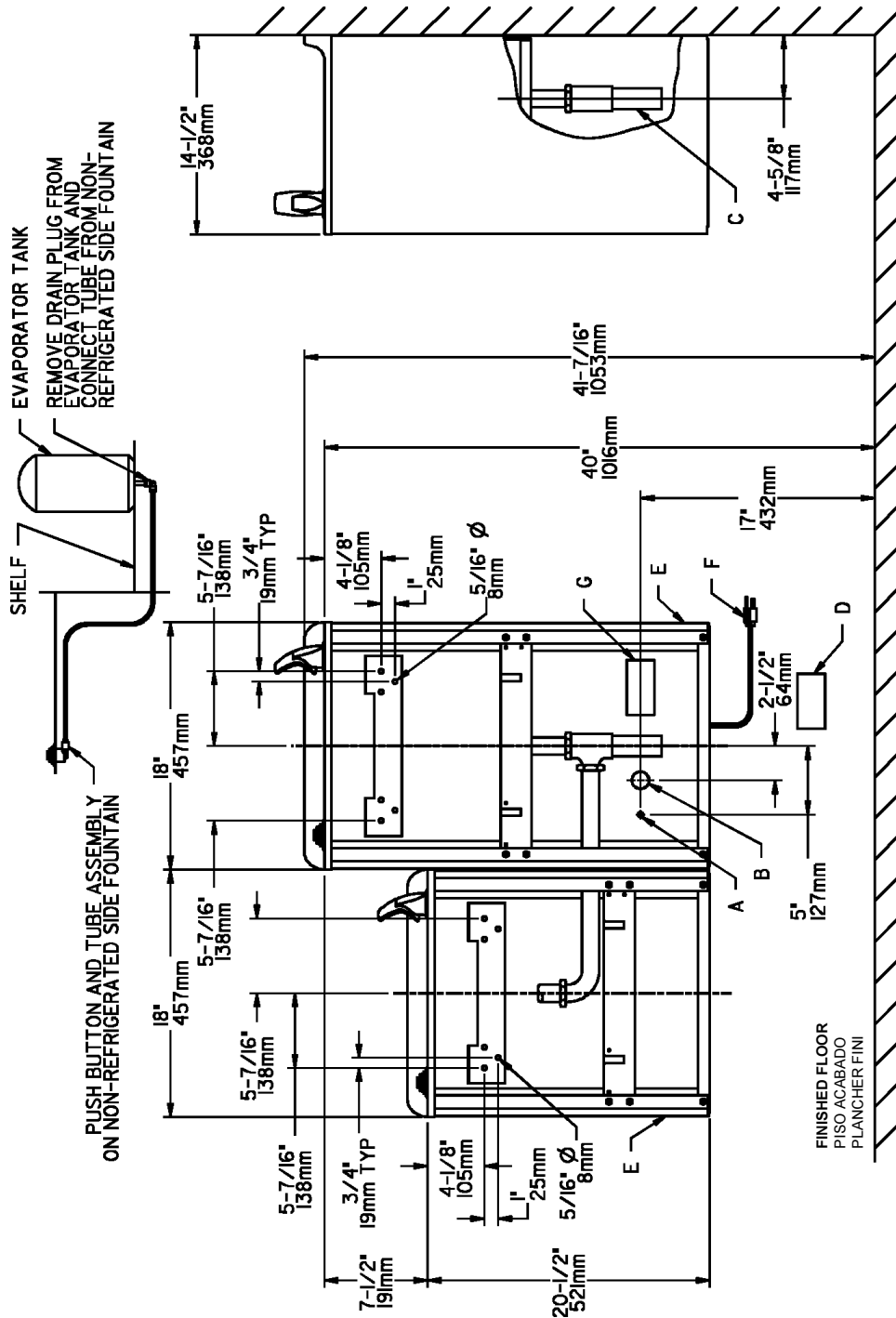
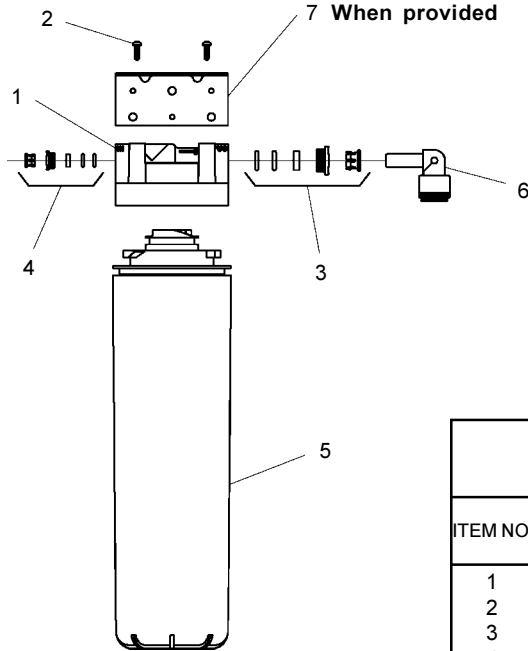

FIG. 2

**LEGEND/LEGENDE**  
**A = RECOMMENDED WATER SUPPLY LOCATION 3/8 O.D. UNPLATED COPPER TUBE CONNECT STUB OUT 1-1/2 IN. (38mm) FROM WALL SHUT OFF BY OTHERS**  
 SE RECOMIENDA UBICAR EL TUBO CORTO DE CONEXIÓN AL TUBO DE COBRE SIN CHAPAR DE 3/8" DE DIÁM. EXT. A 1-1/2" (38 mm) FUERA DE LA PARED COLOCADA POR TERCEROS.

**B = RECOMMENDED LOCATION FOR WASTE OUTLET 1-1/4" O.D. DRAIN**  
 UBICACIÓN RECOMENDADA PARA EL DRENAJE DE SALIDA DE AGUA, DE 1 1/4" DE DIÁMETRO.  
**C = 1-1/4" TRAP NOT FURNISHED**  
 PURGADOR DE 1 1/4" NO PROPORCIONADO  
**D = ELECTRICAL OUTLET LOCATION**  
 UBICACIÓN DE LA TOMA DE ELECTRICIDAD  
**E = INSURE PROPER VENTILATION BY MAINTAINING 4" (102mm) (MIN.) CLEARANCE FROM CABINET LOUVERS TO WALL.**  
 ASEGURE UNA VENTILACIÓN ADECUADA MANTENIENDO UN ESPACIO E 4" (102mm) (MÍN.) DE HOLGURA ENTRE LA REJILLA DE VENTILACIÓN DEL MUEBLE Y LA PARED  
**F = POWER CORD 4 FEET (1219mm) LONG**  
 CABLE ELÉCTRICO DE 4 PIES (1219mm), DE LARGO  
**G = ALT. ELECTRICAL OUTLET LOCATION**  
 UBICACIÓN ALT. DE LA TOMA DE ELECTRICIDAD

ASSUREZ-VOUS UNE BONNE VENTILATION EN GARDANT 4" (102mm) (MIN.) ENTRE LES ÉVÉNENTS DE L'ENCEINTE ET LE MUR.  
 EMPACEMENT ALTERNATIF DE LA PRISE DE COURANT



DESIGN 2000® FILTER PARTS LIST		
ITEM NO.	PART NO.	DESCRIPTION
1	51294C	Filter Head Ass'y
2	70792C	Screw #8-18 X .75 PH
3	70823C	Fitting - Superseal 3/8" (10mm)
4	70822C	Fitting - Superseal 1/4" (6mm)
5	51299C	Filter Ass'y
6	70818C	Elbow - 3/8" (10mm)
7	22490C	Bracket

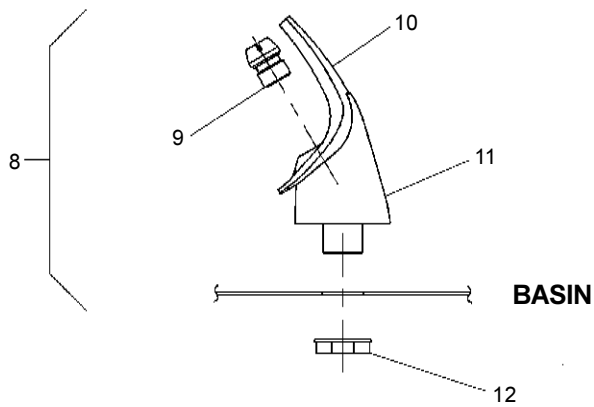

**NOTE:**  
**WHEN INSTALLING REPLACEMENT BUBBLER AND PEDESTAL, TIGHTEN NUT (ITEM 12) ONLY TO HOLD PARTS SNUG IN POSITION. DO NOT OVER TIGHTEN.**

**FIG. 3**

Stream height is factory set at 35 PSI. If supply pressure varies greatly from this, remove Items 1 & 2 and adjust screw on Item 4. Clockwise adjustment will raise stream and counter-clockwise adjustment will lower stream. For best adjustment, stream should hit basin approximately 6-1/2" (165mm) from bubbler.

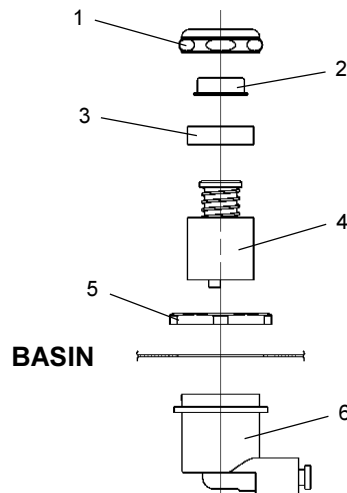

**FIG. 4**

**EWTLA8,14,16\*1C EWTLA14\*2C LWTLA14,20\*1C, 3C**

**PARTS LIST 115V**

ITEM NO.	PART NO.	DESCRIPTION
1	40089C	Cover
2	40048C	Button
3	15005C	Regulator Retaining Nut
4	61313C	Regulator
5	40169C	Hex Nut
6	50986C	Regulator Holder
7	20776C	Basin
8	51349C	Bubbler Assy
9	40322C	Orifice Assy
10	50934C	Housing Assy
11	50168C	Pedestal
12	70012C	Bubbler Locknut
13	31513C	Cold Control
14	31502C	Power Cord (8,14,& 16 GPH)
	35885C	Power Cord (20 GPH)
15	66431C	Condenser (8 GPH)
	66417C	Condenser (14 & 16 GPH)
	66432C	Condenser (20 GPH)
16	21516C	Fan Shroud
17	31490C	Fan Motor (8 & 14 GPH)
	31491C	Fan Motor (16 GPH)
	31492C	Fan Motor (20 GPH)
18	30664C	Fan Blade
19	20239C	Fan Bracket
20	70018C	Fan Blade Nut
21	66201C	Drier (8 GPH)
	66202C	Drier (14 GPH)
	66203C	Drier (16 & 20 GPH)
22*	35787C	Compressor Serv. Pak 8 GPH
	35762C	Compressor Serv. Pak 14 GPH
	35744C	Compressor Serv. Pak. 16 GPH
	35775C	Compressor Serv. Pak. 20 GPH
23	31034C	Overload/Relay Assy (8 GPH)
	31027C	Overload/Relay Assy (14 GPH)
	31029C	Overload/Relay Assy (16 GPH)
	35840C	Overload (20 GPH)
	35843C	Relay (20GPH)
24	35766C	Relay Cover
25	194243901550	Electrical Shield
26	55996C	Strainer
27	45693C	Precooler
28	55909C	Tailpipe Helix
29	66255C	Heat Exchanger (8 GPH)
	66229C	Heat Exchanger (14 GPH)
	66256C	Heat Exchanger (16 GPH)
	66445C	Heat Exchanger (20 GPH)
30	66421C	Evaporator (8 & 14 GPH)
	66420C	Evaporator (16 & 20 GPH)
31	70836C	Reducing Elbow 3/8 to 1/4
32	40022C	Waste Connection Assy
33	40088C	Assy - Tailpipe
34	See Color Table	Panel-Left Side (Right Unit)
35	See Color Table	Panel-Right Side (Right Unit)
36	See Color Table	Panel-Front (Right Unit)
37	See Color Table	Panel-Left Side (Left Unit)
38	See Color Table	Panel-Right Side (Left Unit)
39	See Color Table	Panel-Front (Left Unit)
40	50005C	Gasket - Tailpipe
41	70016C	Nut - Hex
NS	70767C	Evaporator Retaining Clip
NS	70772C	Evaporator Drain Plug

**220V/50Hz**

ITEM NO.	PART. NO.	DESCRIPTION
14	31438C	Power Cord
17	31430C	Fan Motor
22*	35764C	Compressor Serv. Pak
23	31028C	Overload/Relay Assy
24	35768C	Relay Cover

**230V/60Hz**

ITEM NO.	PART. NO.	DESCRIPTION
14	31438C	Power Cord
17	31431C	Fan Motor
22*	35856C	Compressor Serv. Pak
23	35799C	Overload
23	35805C	Relay

**\*INCLUDES RELAY & OVERLOAD. IF UNDER WARRANTY, REPLACE WITH SAME COMPRESSOR USED IN ORIGINAL ASSEMBLY.**

**NOTE:** All correspondence pertaining to any of the above water coolers or orders for repair parts **MUST** include Model No. and Serial No. of cooler, name and part number of replacement part.

**COLOR TABLE**

PANEL COLOR	Item No. 34 Part No.	Item No. 35 Part No.	Item No. 36 Part No.
Gray Beige	20732C	20639C	20675C
Almond	21477C	21465C	20676C
Stainless Stl	20733C	20641C	20672C
Sandalwood	21476C	21463C	21454C
Granite	27186C	27174C	27150C

**COLOR TABLE**

PANEL COLOR	Item No. 37 Part No.	Item No. 38 Part No.	Item No. 39 Part No.
Gray Beige	20646C	20736C	20684C
Almond	21468C	21479C	20685C
Stainless Stl	20648C	20737C	20681C
Sandalwood	21466C	21478C	21456C
Granite	27177C	27189C	27153C