

ELKAY With *FLEXI-GUARD*[®] **INSTALLATION, CARE & USE MANUAL**

EWTLA Pressure Cooler *USES HFC-134A REFRIGERANT*

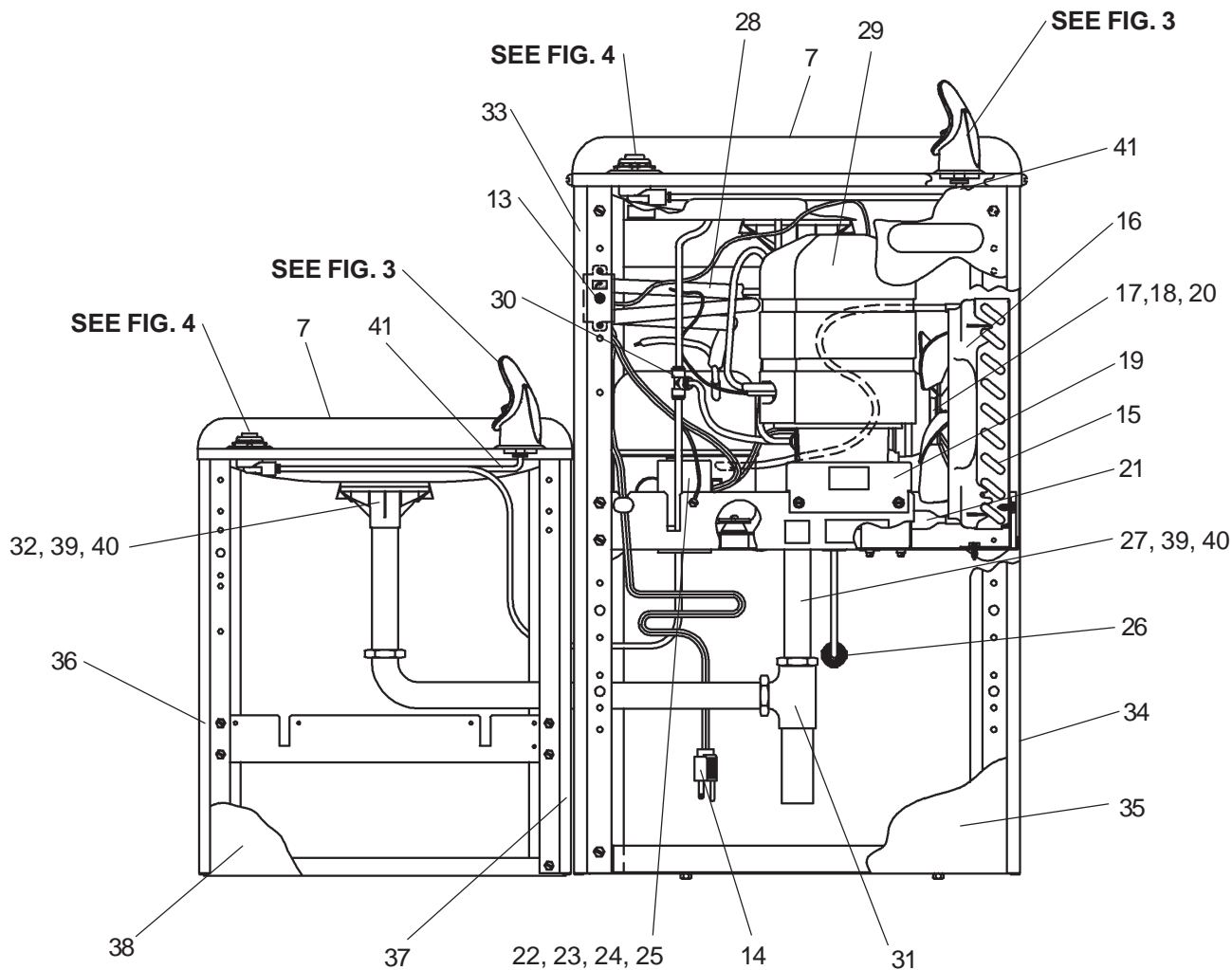

FIG. 1

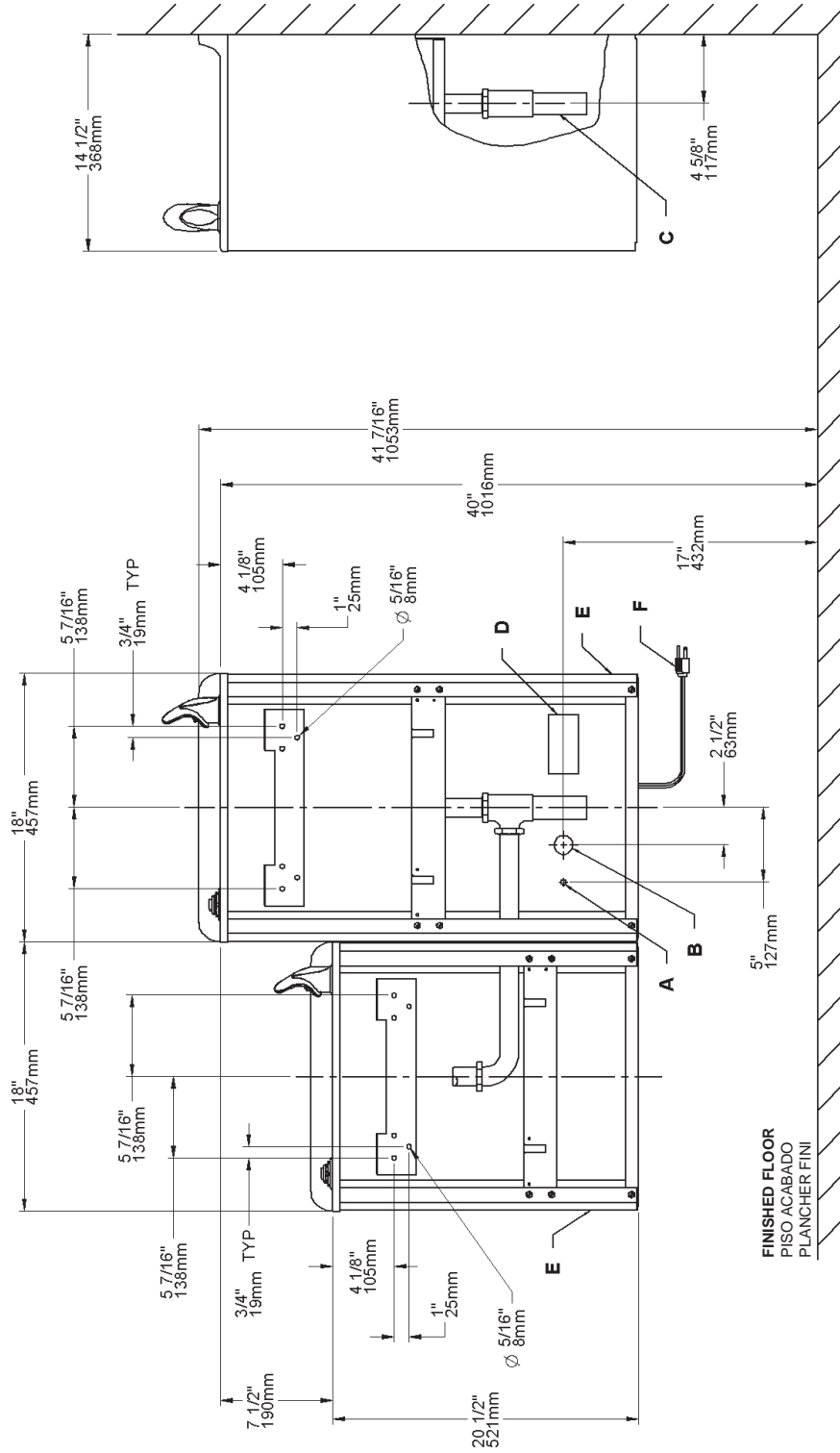

FIG. 2

LEGEND/LEVENDA/LÉGENDE
A = RECOMMENDED WATER SUPPLY LOCATION 3/8 O.D. UNPLATED COPPER TUBE CONNECT STUB OUT 1-1/2 IN. (38mm)
FROM WALL SHUT OFF BY OTHERS

SE RECOMIENDA UBICAR EL TUBO CORTO DE CONEXIÓN AL TUBO DE COBRE SIN CHAPAR DE 3/8" DE DIÁM. EXT. A 1-1/2" (38 mm) FUERA DE LA LLAVE DE PASO EN LA PARED COLOCADA POR TERCEROS.
 EMPLACEMENT RECOMMANDÉ D'ALIMENTATION EN EAU PAR TUBE EN CUIVRE NON PLAQUÉ DE 3/8 PO. (9.5 mm) D.E. CONNECTANT UNE TUYAUTERIE DE 1-1/2 PO. (38 mm) DEPUIS LE ROBINET D'ARRÊT FOURNI PAR D'AUTRES.

B = RECOMMENDED LOCATION FOR WASTE OUTLET 1-1/4" O.D. DRAIN
 UBICACIÓN RECOMENDADA PARA EL DRENAJE DE SALIDA DE AGUA, DE 1 1/4" DE DIÁMETRO.
 EMPLACEMENT RECOMMANDÉ POUR LE DRAIN DE D.E. 1-1/4" DE SORTIE D'EAU.

C = 1-1/4" TRAP NOT FURNISHED
 PURGADOR DE 1 1/4" NO PROPORCIONADO
 SIPHON 1-1/4" NON FOURNI

D = ELECTRICAL OUTLET LOCATION
 UBICACIÓN DE LA TOMA DE ELECTRICIDAD
 EMPLACEMENT DE LA PRISE DE COURANT

E = INSURE PROPER VENTILATION BY MAINTAINING 4" (102mm) (MIN.) CLEARANCE FROM CABINET LOUVERS TO WALL.
 ASEGURE UNA VENTILACIÓN ADECUADA MANTENIENDO UN ESPACIO E 4" (102mm) (MÍN.) DE HOLLGURA ENTRE LA REJILLA DE VENTILACIÓN DEL MUEBLE Y LA PARED
 ASSUREZ-VOUS UNE BONNE VENTILATION EN GARDANT 4" (102mm) (MIN.) ENTRE LES ÉVÉNENTS DE L'ENCEINTE ET LE MUR.

F = POWER CORD 4 FEET (1219mm) LONG
 CABLE ELÉCTRICO DE 4 PIE (1219mm), DE LARGO
 CORDON D'ALIMENTATION 4' (1219mm)

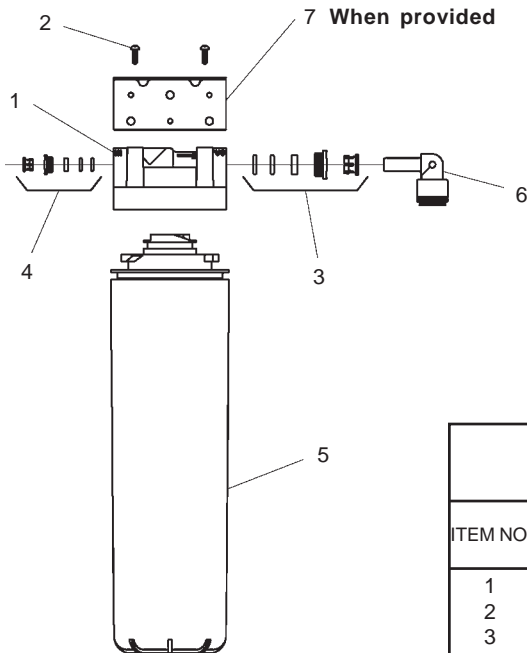
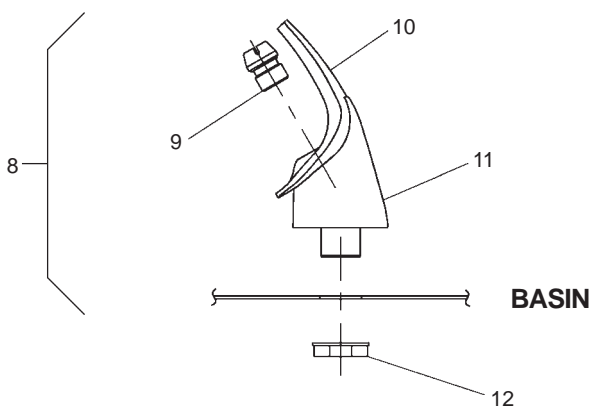

FIG. 5

WATERSENTRY® FILTER PARTS LIST		
ITEM NO.	PART NO.	DESCRIPTION
1	51294C	Filter Head Ass'y
2	70792C	Screw #8-18 X .75 PH
3	70823C	Fitting - Superseal 3/8" (10mm)
4	70822C	Fitting - Superseal 1/4" (6mm)
5	51299C	Filter Ass'y
6	70818C	Elbow - 3/8" (10mm)
7	22490C	Bracket



NOTE:
 WHEN INSTALLING REPLACEMENT BUBBLER AND PEDESTAL, TIGHTEN NUT (ITEM 12) ONLY TO HOLD PARTS SNUG IN POSITION. DO NOT OVER TIGHTEN.

FIG. 3

Stream height is factory set at 35 PSI. If supply pressure varies greatly from this, remove Items 1 & 2 and adjust screw on Item 4. Clockwise adjustment will raise stream and counter-clockwise adjustment will lower stream. For best adjustment, stream should hit basin approximately 6-1/2" (165mm) from bubbler.

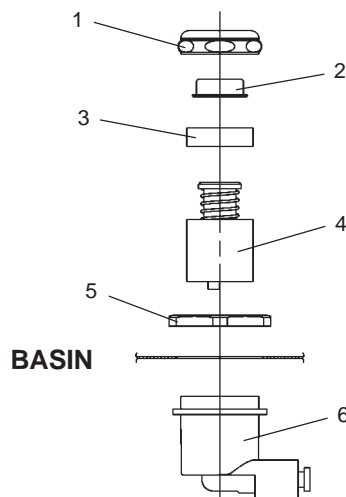

FIG. 4

PARTS LIST 115V

ITEM NO.	PART NO.	DESCRIPTION
1	40089C	Cover
2	40048C	Button
3	15005C	Regulator Retaining Nut
4	61313C	Regulator
5	40169C	Hex Nut
6	50986C	Regulator Holder
7	20776C	Basin
	20713C	Basin (GF Only)
8	56073C	Bubbler Assy
9	40322C	Orifice Assy
10	56011C	Housing Assy
11	55997C	Pedestal
12	75580C	Bubbler Locknut
13	31513C	Cold Control
14	36208C	Power Cord
15	66743C	Condenser
16	56237C	Fan Shroud
17	31490C	Fan Motor
18	30664C	Fan Blade
19	27681C	Fan Bracket
20	70018C	Fan Blade Nut
21	66703C	Drier
*22	36094C	Compressor Serv. Pak
23	36158C	Overload
24	35768C	Relay Cover
25	35959C	Relay
26	55996C	Strainer
27	45702C	Tailpipe Assy
28	66576C	Heat Exchanger
29	66534C	Evaporator
30	70682C	Fitting - Tee
31	40022C	Waste Connection Assy
32	40088C	Assy - Tailpipe
33	See Color Table	Panel-Left Side (Right Unit)
34	See Color Table	Panel-Right Side (Right Unit)
35	See Color Table	Panel-Front (Right Unit)
36	See Color Table	Panel-Left Side (Left Unit)
37	See Color Table	Panel-Right Side (Left Unit)
38	See Color Table	Panel-Front (Left Unit)
39	50368C	Receptor - Drain
40	70750C	Clamp
41	56092C	Poly. Tubing (Cut to Length)
42	100322740560	Gasket (GF)
43	15009C	Nipple - Bubbler (GF)

220V/50Hz

ITEM NO.	PART. NO.	DESCRIPTION
14	36024C	Power Cord
17	31430C	Fan Motor
22*	36085C	Compressor Serv. Pak
23	36195C	Overload
24	35768C	Relay Cover
25	36050C	Relay
NS	35826C	Power Inlet

COLOR TABLE

PANEL COLOR	Item No. 33 Part No.	Item No. 34 Part No.	Item No. 35 Part No.
Gray Beige	20732C	20639C	20675C
Almond	21477C	21465C	20676C
Stainless Stl	20733C	20641C	20672C
Sandalwood	21476C	21463C	21454C
Granite	27186C	27174C	27150C
Light Gray	27187C	27175C	27154C

COLOR TABLE

PANEL COLOR	Item No. 36 Part No.	Item No. 37 Part No.	Item No. 38 Part No.
Gray Beige	20646C	20736C	20684C
Almond	21468C	21479C	20685C
Stainless Stl	20648C	20737C	20681C
Sandalwood	21466C	21478C	21456C
Granite	27177C	27189C	27153C
Light Gray	27178C	27190C	27154C

*INCLUDES RELAY & OVERLOAD. IF UNDER WARRANTY, REPLACE WITH SAME COMPRESSOR USED IN ORIGINAL ASSEMBLY.

NOTE: All correspondence pertaining to any of the above water coolers or orders for repair parts MUST include Model No. and Serial No. of cooler, name and part number of replacement part.

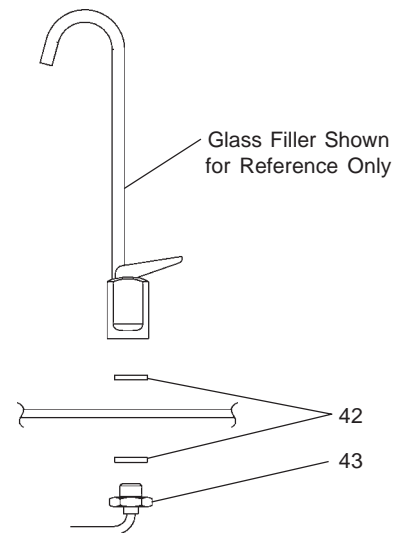

FIG. 6