

Installation/Care/Use Manual

USES HFC-134A REFRIGERANT

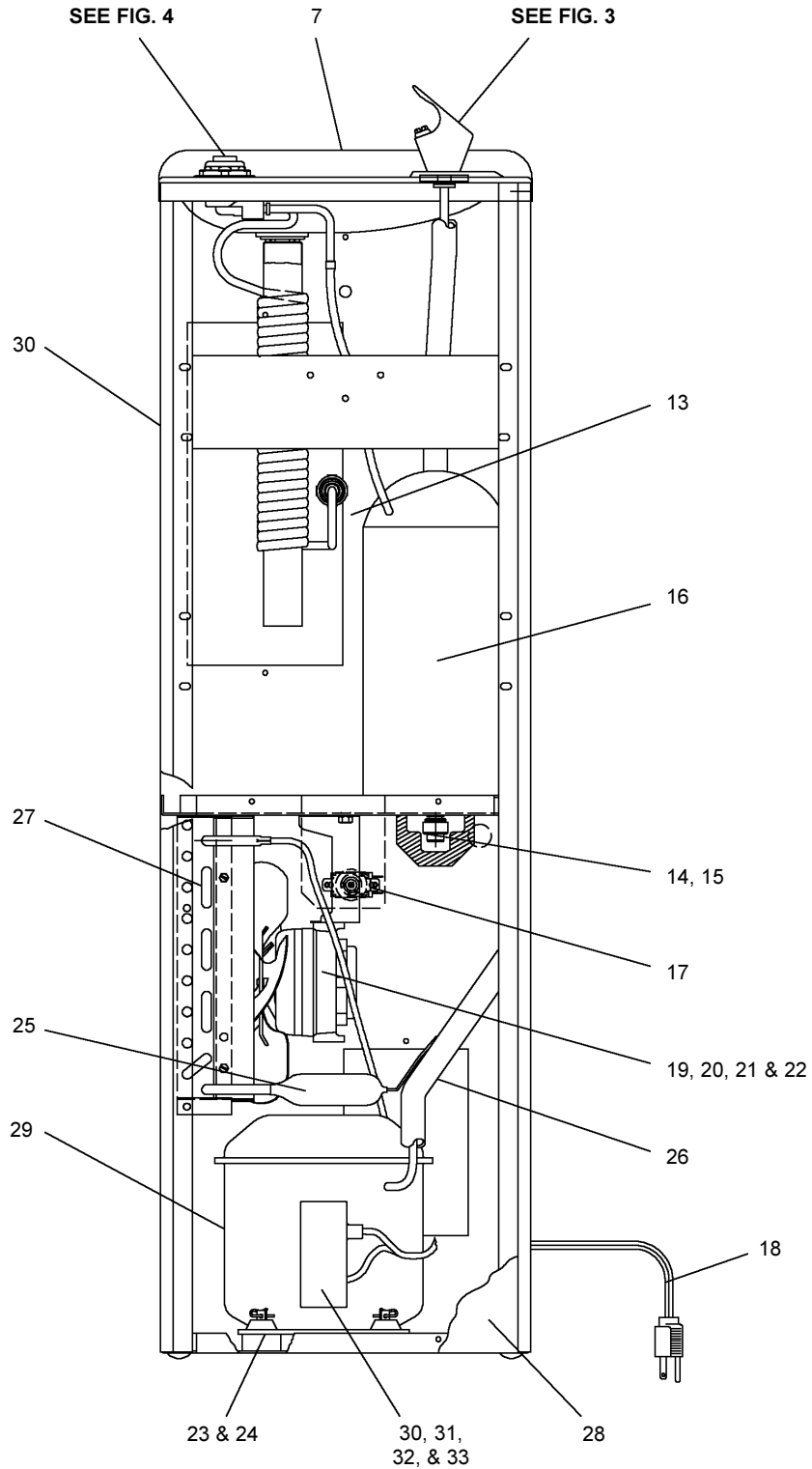

FIG. 1

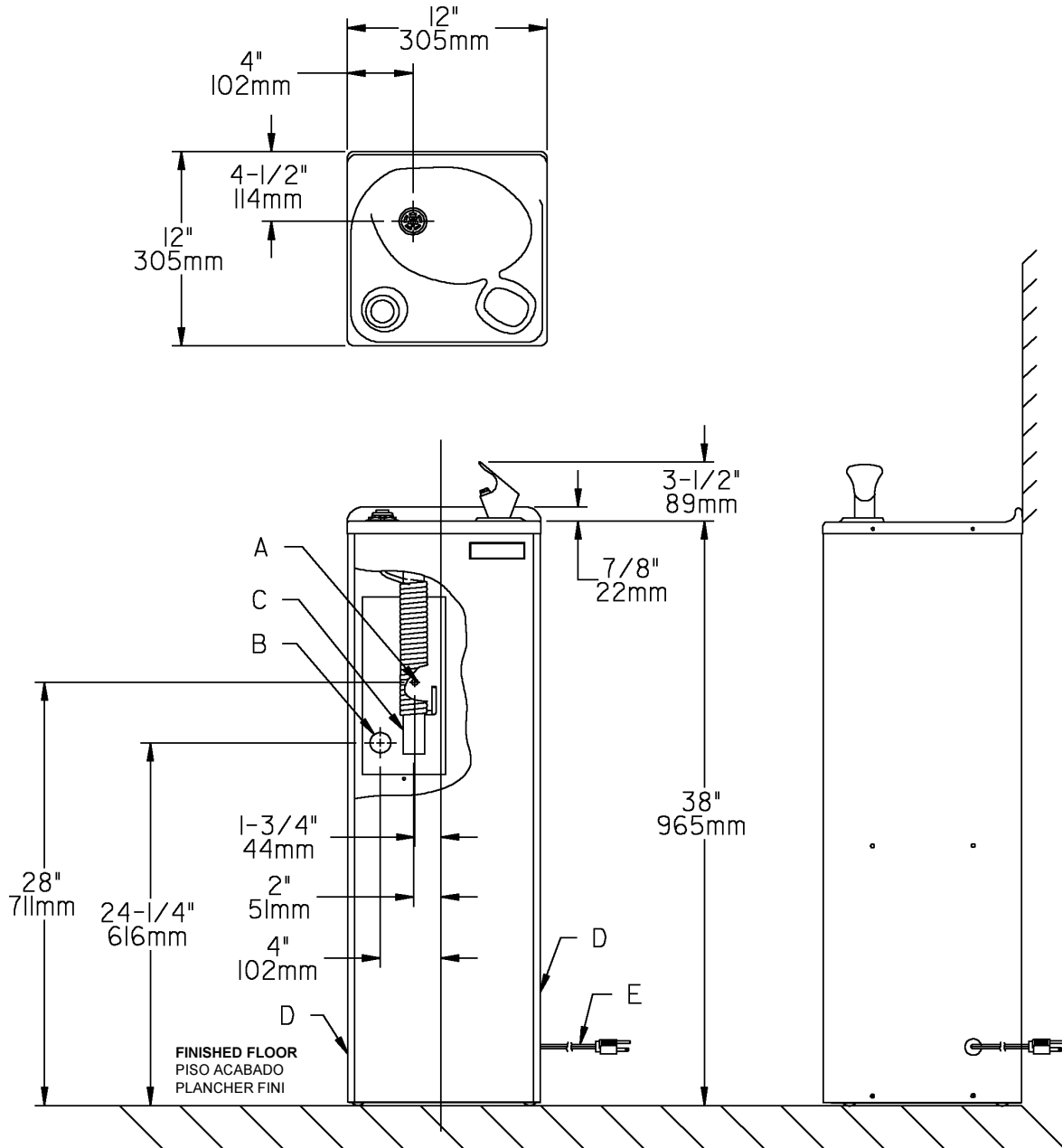

FIG. 2

LEGEND/LEYENDA/LÉGENDE

A = RECOMMENDED WATER SUPPLY LOCATION 3/8 O.D. UNPLATED COPPER TUBE CONNECT STUB 1-1/2" (38mm) OUT FROM WALL SHUT OFF BY OTHERS

SE RECOMIENDA UBICAR EL TUBO DE CONEXIÓN AL TUBO DE COBRE SIN CHAPAR DE 3/8" DE DIAM. EXT. A 1-1/2" (38mm) FUERA DE LA LLAVA DE PASO EN LA PARED COLOCADA POR TERCEROS.

EMPLACEMENT RECOMMANDÉ D'ALIMENTATION EN EAU PAR TUBE EN CUIVRE NON PLAQUÉ DE 3/8 PO. (9,5mm) D.E. CONNECTANT UNE TUYAUTERIE DE 1-1/2 PO. (38mm) DEPUIS LE ROBINET D'ARRÊT FOURNI PAR D'AUTRES.

B = RECOMMENDED LOCATION FOR WASTE OUTLET 1-1/4" O.D. DRAIN

UBICACIÓN RECOMENDADA PARA EL DRENAJE DE SALIDA DE AGUA, DE 1-1/4" DE DIÁMETRO.

EMPLACEMENT RECOMMANDÉ POUR LE DRAIN DE D.E. 1-1/4" DE SORTIE D'EAU.

C = 1-1/4 TRAP NOT FURNISHED

PURGADOR DE 1-1/4 NO PROPORCIONADO

SIPHON 1-1/4 NON FOURNI

D = INSURE PROPER VENTILATION BY MAINTAINING 4" (102mm) (MIN.) CLEARANCE FROM CABINET LOUVERS TO WALL.

ASEGURE UNA VENTILACIÓN ADECUADA MANTENIENDO UN ESPACIO E 4" (102mm) (MÍN.) DE HOLGURA ENTRE LA REJILLA DE VENTILACIÓN DEL MUEBLE Y LA PARED

ASSUREZ-VOUS UNE BONNE VENTILATION EN GARDANT 4" (102mm) (MÍN.) ENTRE LES ÉVENTS DE L'ENCEINTE ET LE MUR.

E = POWER CORD 4 FEET (1219mm) LONG

CABLE ELÉCTRICO DE 4 PIE (1219mm), DE LARGO

CORDON D'ALIMENTATION 4' (1219mm)

Note: When installing replacement bubbler and pedestal, tighten nut (Item 12) only to hold parts snug in position. **Do not over tighten.**

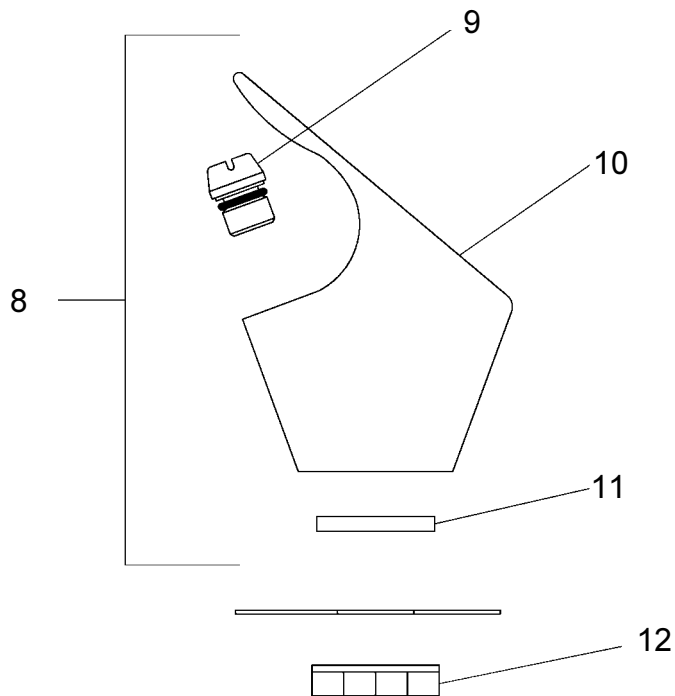

FIG. 3

Stream height is factory set at 35 PSI. If supply pressure varies greatly from this, remove Items 1 & 2 and adjust screw on Item 4. Clockwise adjustment will raise stream and counter-clockwise adjustment will lower stream. For best adjustment, stream should hit basin approximately 6-1/2" (165mm) from bubbler.

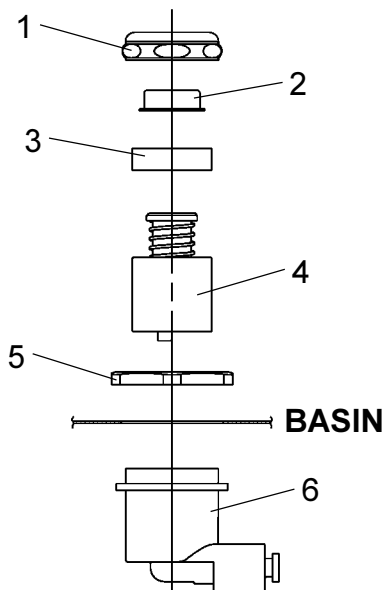

FIG. 4

FGDF7105,10*1C,2C

PARTS LIST 115V

ITEM NO.	PARTNO.	DESCRIPTION
1	40089C	Cover
2	40048C	Button
3	15005C	Regulator Retaining Nut
4	61313C	Regulator
5	40169C	Hex Nut
6	50986C	Regulator Holder
7	22543C	Basin & Precooler assy
8	45314C	Bubbler Assy
9	40322C	Orifice Assy
10	45312C	Bubbler Body
11	100322740560	Washer
12	70012C	Bubbler Locknut
13	55996C	Strainer
14	70767C	Clip-Evaporator Retainer
15	70772C	Drain Plug
16	66442C	Evaporator Assy (5GPH)
	66433C	Evaporator Assy (10GPH)
17	31513C	Cold Control
18	31501C	Power Cord
19	31490C	Fan Motor
20	30664C	Fan Blade
21	70018C	Fan Blade Nut
22	20282C	Fan Motor Bracket
23	70418C	Washer
24	70184C	Hair Pin Cotter
25	66200C	Drier (5GPH)
	66202C	Drier (10GPH)
26	66300C	Heat Exchanger (5GPH)
26a	66302C	Heat Exchanger (10GPH)
26b	66508C	Heat Exchanger (10GPH)
27	66303C	Condenser (5GPH)
	66304C	Condenser (10GPH)
28	20460C	Front Panel (Stainless Steel)
	21482C	Front Panel (Sandalwood)
29	21239C	Cabinet (Stainless Steel)
	21486C	Cabinet (Sandalwood)
30*	35786C	Compressor Serv. Pak PW3HK7 (5GPH)
30a*	35767C	Compressor Serv. Pak FF7.5HBK (10GPH)
30b*	35947C	Compressor Serv. Pak EM65 (10GPH)
31	35766C	Cover - Relay
31a	35766C	Cover - Relay
31b	35768C	Cover - Relay
32	31038C	Overload/Relay Assy 1.350.398 (5GPH)
32a	31025C	Overload/Relay Assy 1.350.358 (10GPH)
32b	31039C	Overload/Relay Assy P600B/427NFBYY(10GPH)
33b	35935C	Capacitor - Run

PARTS LIST 230V-50/60Hz

ITEM NO.	PARTNO.	DESCRIPTION
18	31505C	Power Cord
19	31430C	Fan Motor
*30	35788C	Compressor Serv Pak (5 GPH)
	35763C	Compressor Serv Pak (10 GPH)
31	35768C	Relay Cover (10 GPH)
32	31035C	Overload/Relay Assy (5 GPH)
	31024C	Overload/Relay Assy (10 GPH)

*REPLACE WITH SAME COMPRESSOR USED IN ORIGINAL ASSEMBLY.
 NOTE: All correspondence pertaining to ELKAY water coolers or orders for repair parts MUST include Model No. and Serial No. of cooler, name and part number of replacement part.