

# Owners Manual

## Freeze Resistant Wall Mount Stone Fountains

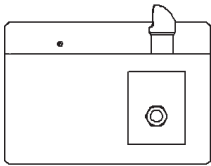

4592FR

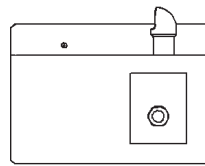
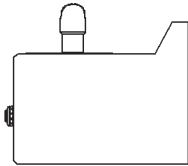

4593FR

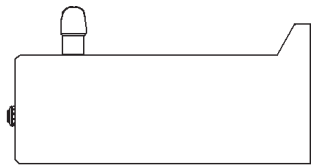

### Installer

To assure you install this model easily and correctly, PLEASE READ THESE SIMPLE INSTRUCTIONS BEFORE STARTING THE INSTALLATION. CHECK YOUR INSTALLATION FOR COMPLIANCE WITH PLUMBING, ELECTRICAL AND OTHER APPLICABLE CODES. After installation, leave these instructions inside the fountain for future reference.

This Freeze Resistant Fountain is shipped in two separate cartons. The second carton contains the Freeze Resistant Package that is installed on an interior heated wall. Refer to the Freeze Resistant Package for the rough-in dimensions for installation.

## IMPORTANT

**ALL SERVICE TO BE PERFORMED BY AN AUTHORIZED SERVICE PERSON**

### IMPORTANT! INSTALLER PLEASE NOTE.

THE GROUNDING OF ELECTRICAL EQUIPMENT SUCH AS TELEPHONE, COMPUTERS, ETC. TO WATER LINES IS A COMMON PROCEDURE. THIS GROUNDING MAY BE IN THE BUILDING OR MAY OCCUR AWAY FROM THE BUILDING. THIS GROUNDING CAN CAUSE ELECTRICAL FEEDBACK INTO A FOUNTAIN, CREATING AN ELECTROLYSIS WHICH CAUSES A METALLIC TASTE OR AN INCREASE IN THE METAL CONTENT OF THE WATER. THIS CONDITION IS AVOIDABLE BY USING THE PROPER MATERIALS AS INDICATED. ANY DRAIN FITTINGS PROVIDED BY THE INSTALLER SHOULD BE MADE OF PLASTIC TO ELECTRICALLY ISOLATE THE FOUNTAIN FROM THE BUILDING PLUMBING SYSTEM.

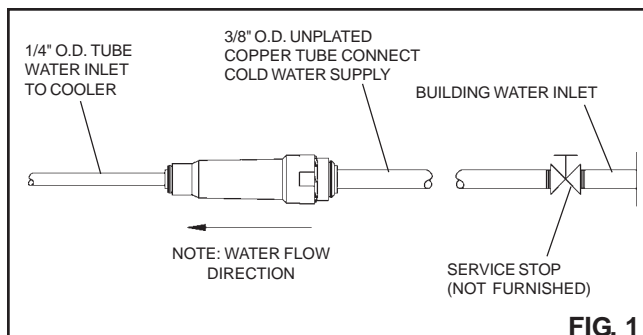

### OPERATION OF QUICK CONNECT FITTINGS

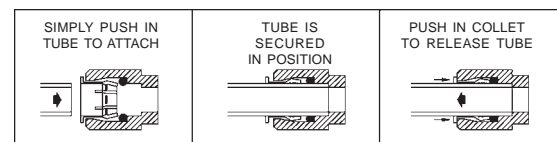

PUSHING TUBE IN BEFORE PULLING IT OUT HELPS TO RELEASE TUBE

**FIG. 2**

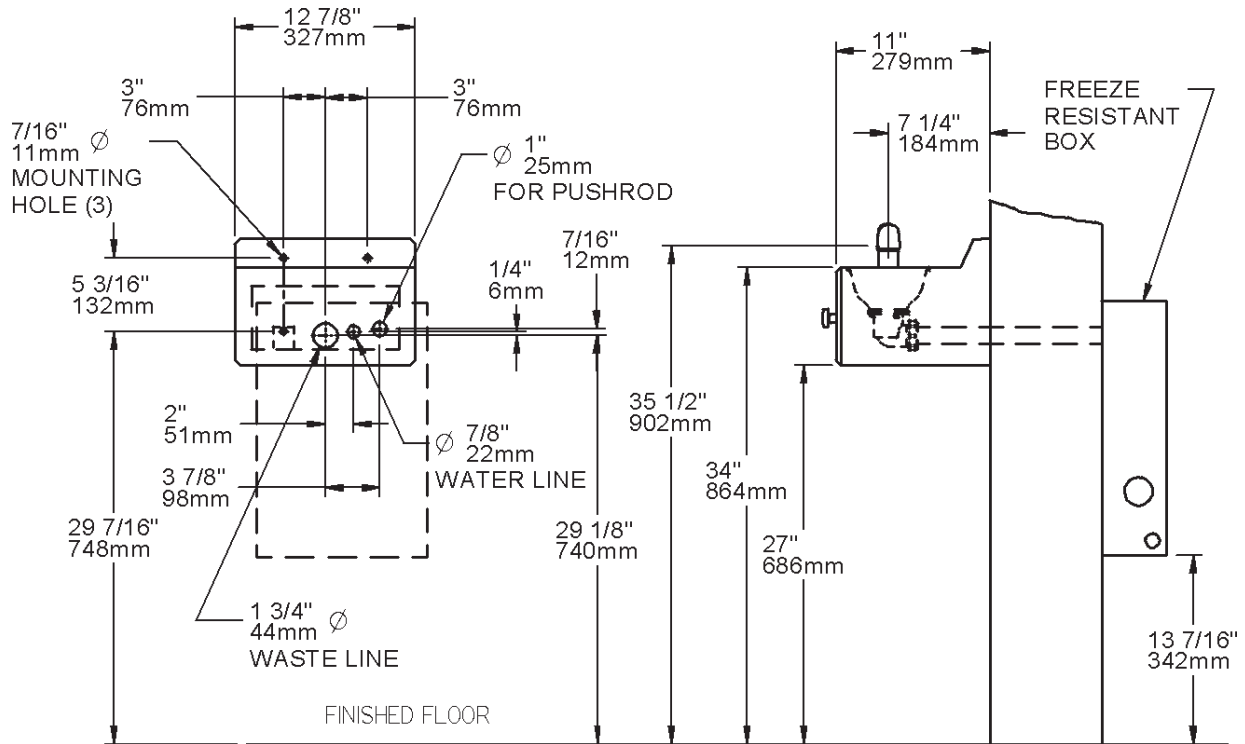

4592FR ROUGH-IN

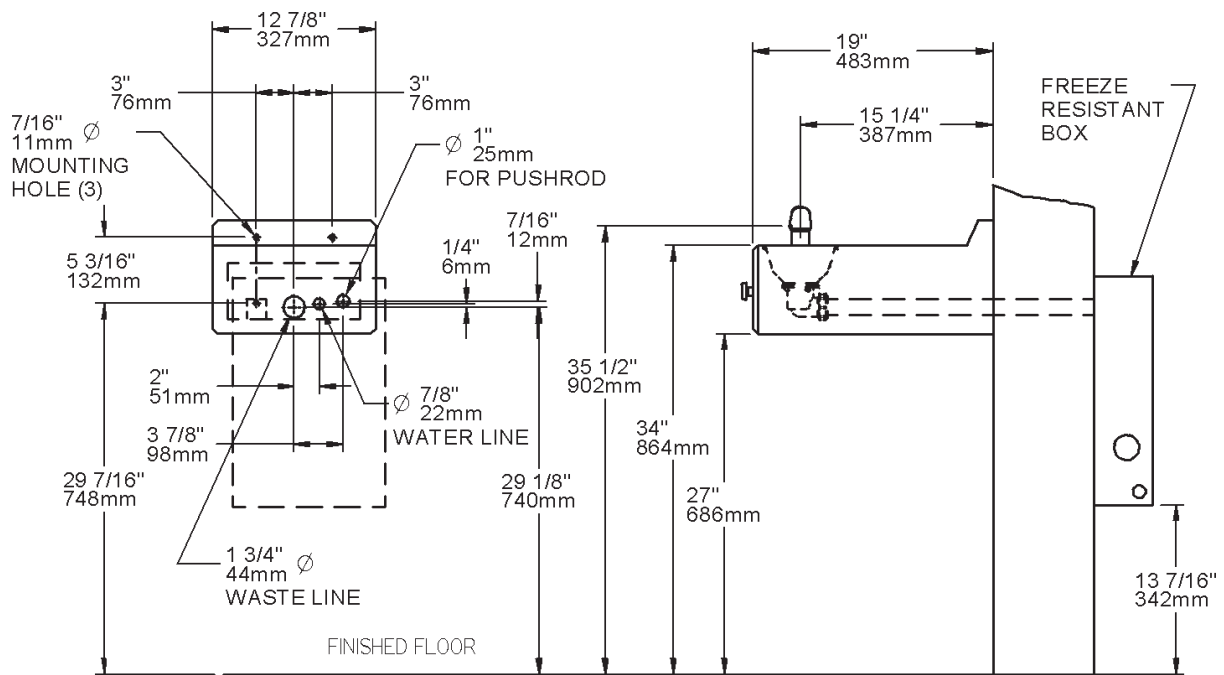

4593FR ROUGH-IN

## INSTALLATION INSTRUCTIONS

1. This fountain is to be mounted on a smooth, flat, finished wall surface with adequate support structure.  
**NOTE: Wall mounting structure must be capable of supporting 300 lb. load on fountain.**
2. Wall should already be framed for the fountain using dimensions shown in rough-in's on Page 2. Shown dimensions pertain to installation location.
3. Remove bottom cover from fountain and save the screws. Assemble the push rod to the fountain. (Push rod provided with freeze resistant box)
4. Install the fountain using bolts and washers (not provided). Tighten securely.
5. Attach drain tube to fountain and cut to required length using the freeze resistant box as a guide.
6. Install freeze resistant box - see box instructions.
7. Install a service stop (not provided) and make water supply connection from the stop to the strainer in the freeze resistant box. **DO NOT SOLDER TUBES INSERTED INTO THE STRAINER AS DAMAGE TO THE O-RINGS MAY RESULT.**
8. Connect fountain water line to freeze resistant box - see box instructions. Replace the bottom cover.

### SUGGESTED CONFIGURATION FOR EXPOSED MOUNTING BOLTS

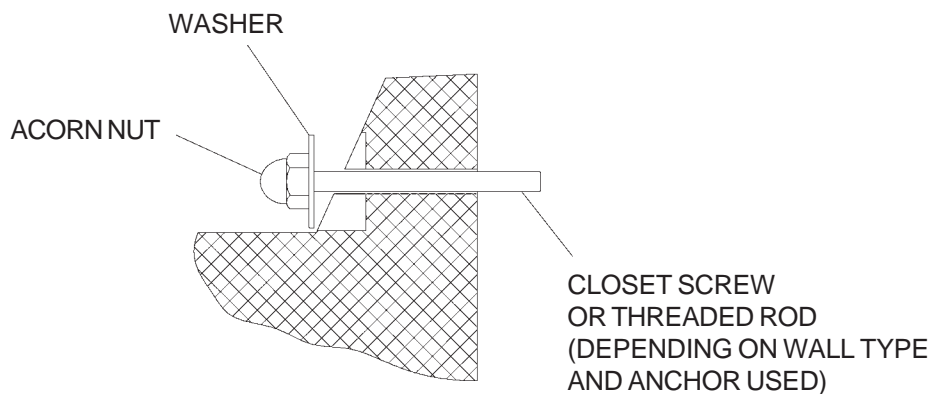

FIG. 3

ITEMIZED PARTS LIST		
ITEM NO.	PART NO.	DESCRIPTION
1	100147140560	Drain Gasket
2	100322740560	Bubbler Gasket
3	101570540560	Drain Gasket
4	15013C	Bubbler Tube Assy.
5	170705042830	Basin
6-A	400942308640	Bubbler
6-B	98287C	Bubbler Assembly
7	56092C	Poly Tubing (Cut To Length)
8	56121C	Drain Elbow
9	600985551640	Drain Plug Assy.
10	66346C	Drain Tube
11	70793C	Elbow - 1/4"
12	75588C	Slip Joint Nut 1-1/4"
13	75589C	Gasket

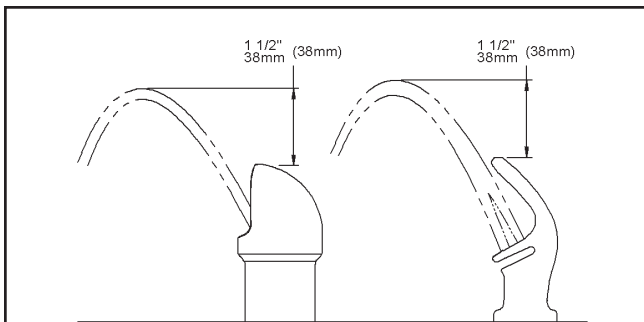
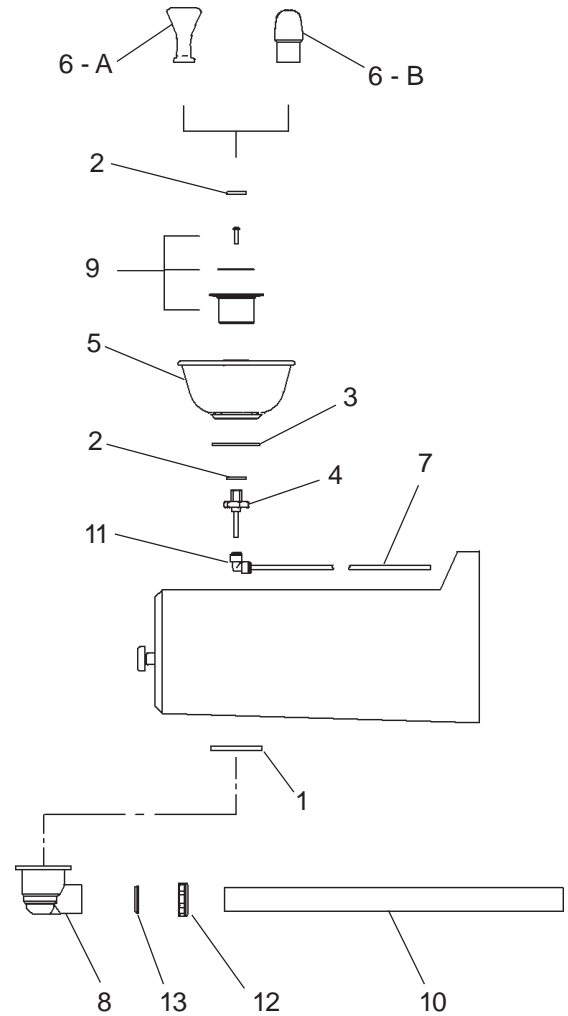

FIG. 4

**STREAM HEIGHT ADJUSTMENT:** Stream height is factory set at 35 PSI. If supply pressure varies greatly from this, adjust screw on regulator in freeze resistant box. Clockwise adjustment will raise stream and counter-clockwise adjustment will lower stream. For best adjustment, stream should hit basin approx. 6-1/2" from bubbler.



4592FR SHOWN

**TROUBLE SHOOTING AND MAINTENANCE**

**Orifice Assy:** Mineral deposits on orifice can cause water flow to spurt or not regulate. Mineral deposits may be removed from the orifice with a small round file not over 1/8" diameter or small diameter wire.

**CAUTION: DO NOT** file or cut orifice material.

**Stream Regulator:** If orifice is clean, regulate flow as in "Stream Height" instructions above. If replacement is necessary, see freeze resistant box parts list for correct regulator part number.

**Actuation of Quick Connect Water Fittings:** Cooler is provided with lead-free connectors which utilize an o-ring water seal. To remove tubing from the fitting, relieve water pressure, push in on the gray collar while pulling on the tubing. (See Fig.2) To insert tubing, push tube straight into fitting until it reaches a positive stop, approximately 3/4".