



Remote Chiller



MODEL SJ1-Q



Certified to NSF/ANSI 61.

CABINET

Manufactured of rust-resistant heavy gauge galvanized steel. Front and rear panels removable for servicing.

PLUMBING CONNECTIONS

1/4" O.D. stainless steel tubing inlet and outlet.

ELECTRICAL CONNECTION

7/8" diameter opening for conduit connection.

COOLING UNIT

Tank style evaporator. Tank is stainless steel, with drain plug. Fully insulated.

TEMPERATURE CONTROL

Positive sensing thermostat for controlling temperature of evaporator/chiller storage water. Factory set for 40°F water. Adjustable to 50°.

CONDENSER

Copper/aluminum construction.

REFRIGERATION SYSTEM

Hermetically sealed, positive start compressor with lifetime lubrication and built-in overload protection, efficient capillary sizing, large capacity dryer-strainer, and self-lubricated fan cools copper/aluminum condenser. System uses R134A refrigerant. Test pressures, highside 325 psig., lowside 140 psig. Protected by Halsey Taylor's Limited 5 Year Warranty.

VENTILATION

This unit is suitable for installation underneath a conventional kitchen sink, in a cabinet not less than 36" (914mm) wide (inside dimension). Two air openings with a minimum of 40" square (1016mm/square) each, minimum of 75% open area, must be provided in the cabinet. One opening must be in the overhang of the toe space and the other opening near the top of the cabinet. The remote unit must be installed with a minimum of 3" clearance between the unit and the rear wall of the cabinet. It can be installed flush against either side wall of the cabinet. The side louvers which are not against the cabinet must not be blocked by objects located within 4" (102mm) of the louvers. In addition, a minimum of 1" to 2" (25 to 51mm) clearance must be provided between the toe space air opening and the front of the unit.

ELECTRICAL

Furnished with 6" leads enclosed in junction box for direct connection to standard 115 volt, 60 Hz, single phase.

SUGGESTED SPECIFICATIONS

Shall deliver 1.3 GPH of 50°F water at 90°F ambient and 80°F inlet water. Designed for use with any drinking fountain. Compressor shall be hermetically sealed. Manufacturer shall certify unit to be lead free as defined by the Safe Drinking Water Act. System controlled by adjustable thermostat. Complies with ARI Standard 1010.

Unit can service 1 fountain. Locate chiller within 15 feet of fountain for optimum performance.

NOTE: Continued product improvement makes specifications subject to change without notice. See Halsey Taylor website for most current spec sheet.

JOB NAME: _____

 ENGINEER/CONTRACTOR NAME: _____

 APPROVAL: _____
 DATE: _____

COMPACT REMOTE CHILLER								
Model No.	GPH Capacity Cooled to 50° F*				Base Rate Cap.	F.L. Amps	Shipping Weight lb.	Rated Watt Usage
	Ambient Air Temp							
	70°F	80°F	90°F†	100°F				
SJ1-Q	1.8	1.7	1.5	1.4	1.5	1.7	33	155

* With projector service at 1 ft. from outlet and supply water at 80° F

† UL listed and complies with ARI Standard 1010

NOTE: A service stop (not included) should be installed at the cooler inlet line.



Accessories: There are no frames, grilles, shelves, cradles or covers available at this time.

SJ1-Q

Compact Remote Chiller

(CONTINUED)

INSTALLATION

If remote chiller unit is physically placed against barrier or in enclosure of any kind, 4" air space must be allowed on all sides.

For optimum performance locate chiller within 15 feet of fountain.

OPERATING PRESSURES:
Supply water - 105 psi maximum

Dimensions
17 1/8"W x 7 1/16"D x 14"H

Shipping weight: 35 lbs.

NOTE: A service stop (not included) should be installed at the cooler inlet line.

TOP VIEW

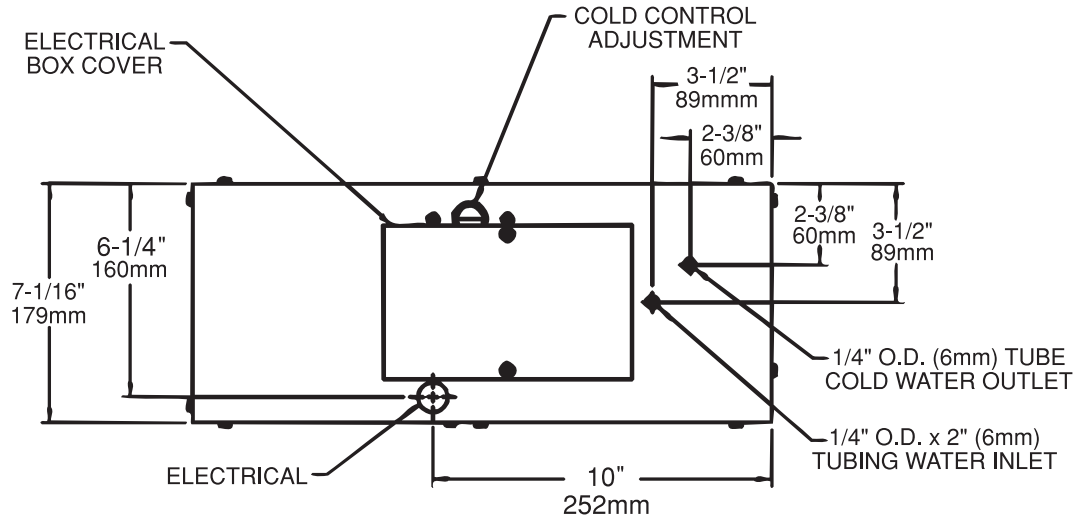

FRONT VIEW

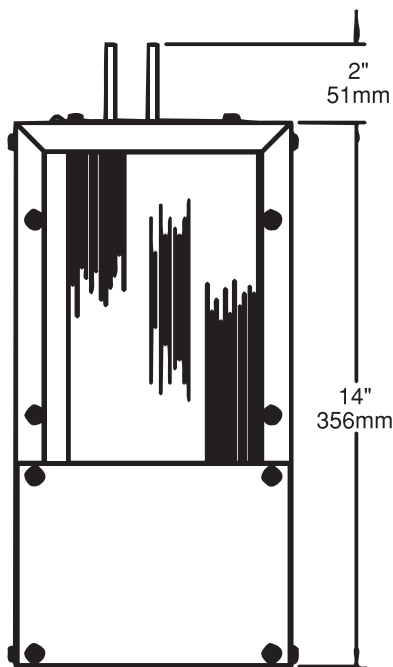

SIDE VIEW

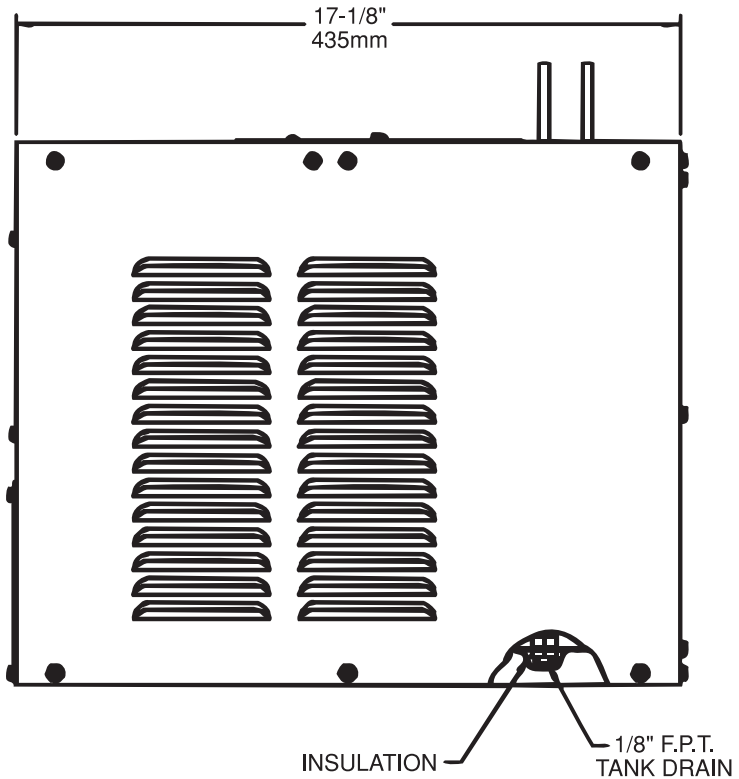

Halsey Taylor®