

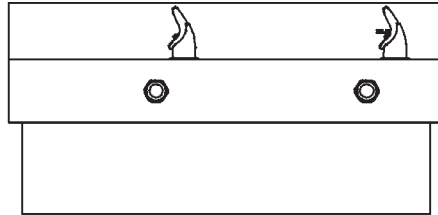

EDF210C & EDF310C Series Fountains

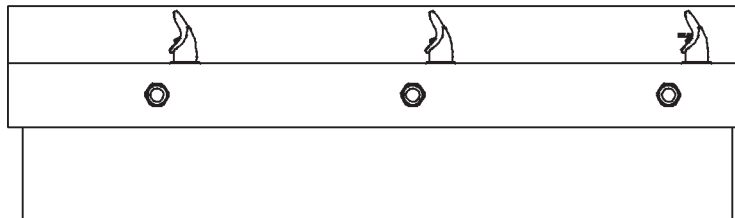

EDF210C TWO STATION FOUNTAIN



EDF310C THREE STATION FOUNTAIN

IMPORTANT

ALL SERVICE TO BE PERFORMED BY AN AUTHORIZED SERVICE PERSON

IMPORTANT! INSTALLER PLEASE NOTE.

THE GROUNDING OF ELECTRICAL EQUIPMENT SUCH AS TELEPHONE, COMPUTERS, ETC. TO WATER LINES IS A COMMON PROCEDURE. THIS GROUNDING MAY BE IN THE BUILDING OR MAY OCCUR AWAY FROM THE BUILDING. THIS GROUNDING CAN CAUSE ELECTRICAL FEEDBACK INTO A FOUNTAIN, CREATING AN ELECTROLYSIS WHICH CAUSES A METALLIC TASTE OR AN INCREASE IN THE METAL CONTENT OF THE WATER. THIS CONDITION IS AVOIDABLE BY USING THE PROPER MATERIALS AS INDICATED. ANY DRAIN FITTINGS PROVIDED BY THE INSTALLER SHOULD BE MADE OF PLASTIC TO ELECTRICALLY ISOLATE THE FOUNTAIN FROM THE BUILDING PLUMBING SYSTEM.

INSTALLATION INSTRUCTIONS

1. Familiarize yourself with the components of the drinking fountain.
2. Determine location of rough-in and plumbing connections. Mount hanger bracket(s) to wall at desired height.
3. Install fountain to wall. Install additional fasteners to bolt fountain securely to wall.
4. Connect strainer to water supply (service stop). Refer to figure 5. **DO NOT SOLDER TUBES INSERTED INTO THE STRAINER AS DAMAGE TO THE O-RINGS MAY RESULT.** Connect trap to waste stub and fountain.
5. Turn on water supply and check for leaks at all plumbing and drain connections. Fix all leaks as required.

**ROUGH - IN DIMENSIONS
EDF210C (TWO STATION)**

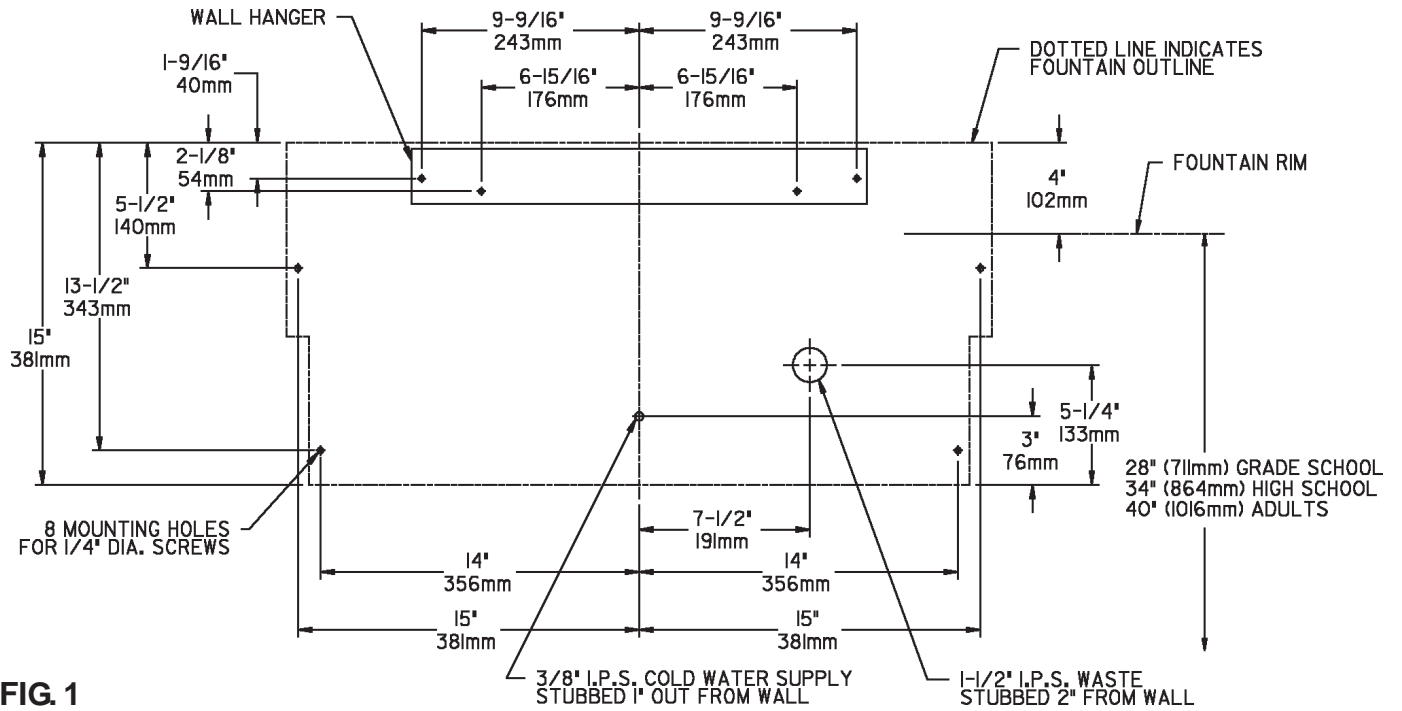

FIG. 1

**ROUGH - IN DIMENSIONS
EDF310C (THREE STATION)**

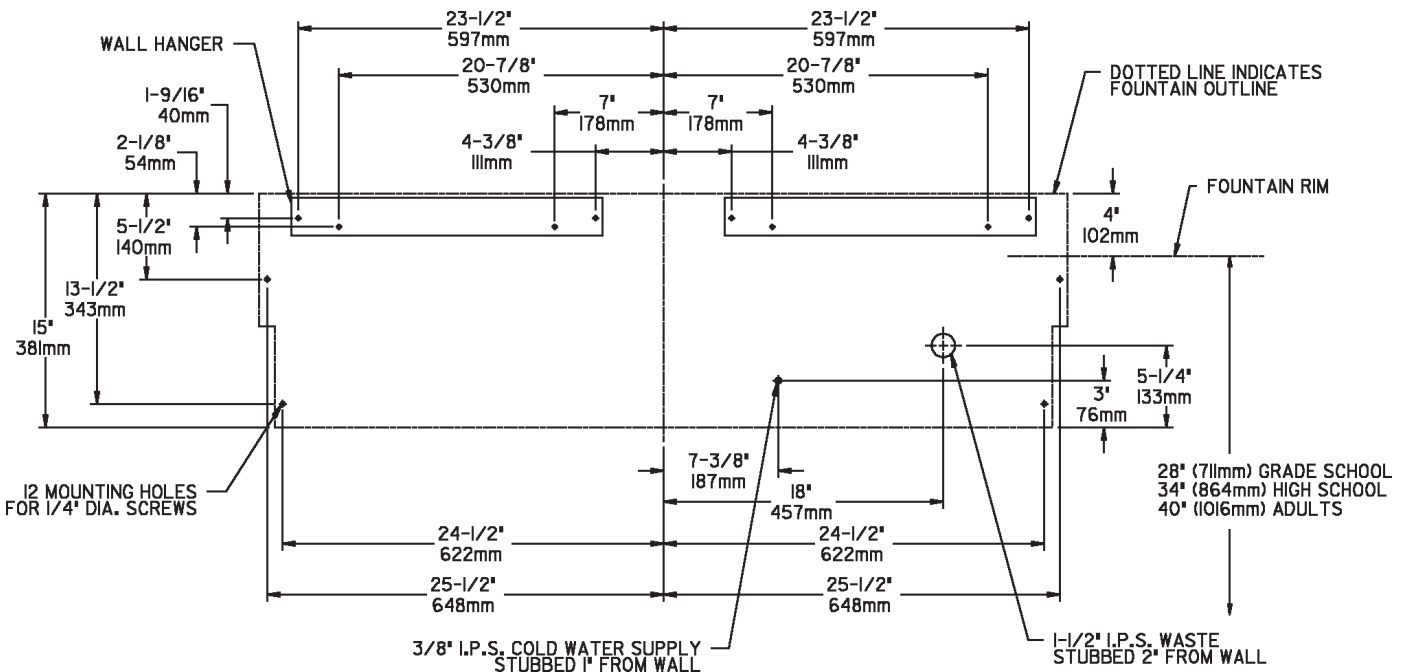
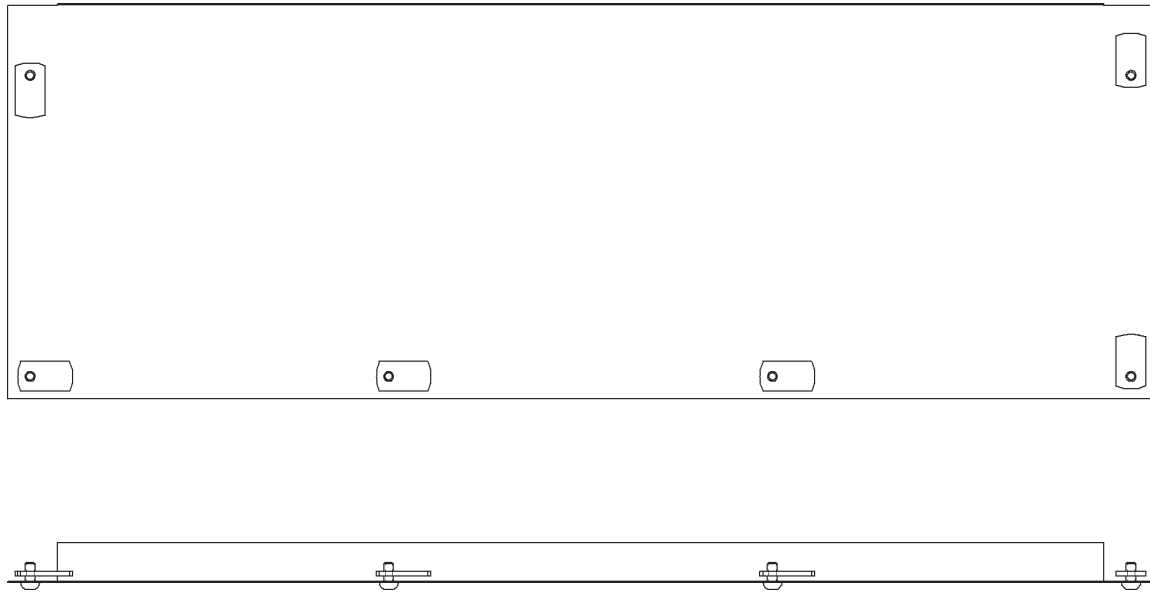

FIG. 2



HOW TO ATTACH COVER PLATE

STEP 1.

POSITION WELD NUTS AND SCREWS AS SHOWN IN THE ABOVE PICTURE.

STEP 2.

POSITION PLATE TO BOTTOM OF FOUNTAIN KEEPING EQUAL MARGIN ON EACH SIDE.

STEP 3.

TIGHTEN SCREWS - AS SCREWS ARE DRAWN UP THE WING OF THE WELD NUT WILL SANDWICH THE FLANGE OF THE FOUNTAIN.

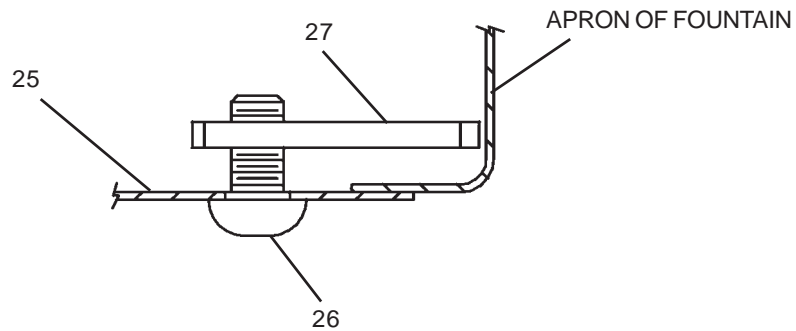

EDF210C / EDF310C FOUNTAIN

ITEMIZED PARTS LIST

ITEM NO.	PART NO.	DESCRIPTION
1	56073C	Bubbler Assy.
2	40169C	Hex Nut
3	40048C	Button
4	40089C	Cover
5	40322C	Orifice Assy.
6	56011C	Bubbler Housing
7	55997C	Pedestal
8	61313C	Regulator
9	75580C	Locking Nut
10	45336C	Strainer/Ferrule Assy.
11	50074C	Gasket - Tailpipe
12	28568C	Fountain
13	55996C	Strainer
14	56092C	Polytubing
15	70682C	Tee - 1/4
16	45852C	Trap Assy.
17	45853C	Wasteline Tee Assy.
18	45854C	Tailpipe
19	15005C	Regulator Retaining Nut
20	28580C	Hanger Bracket
21	50986C	Regulator Holder
22	45855C	Wasteline
23	----	----
24	----	----
25	28332C	Bottom Cover Plate
26	75701C	Machine Screw 1/4-20 x 1/2
27	75700C	Weld Nut 1/4-20 x 1 1/4 Long

FIG. 3

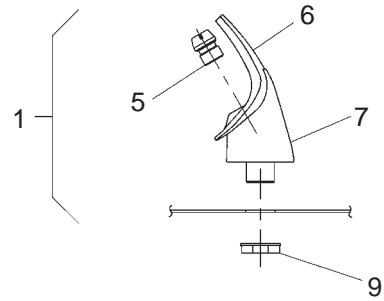

1 - SEE FIG. 3

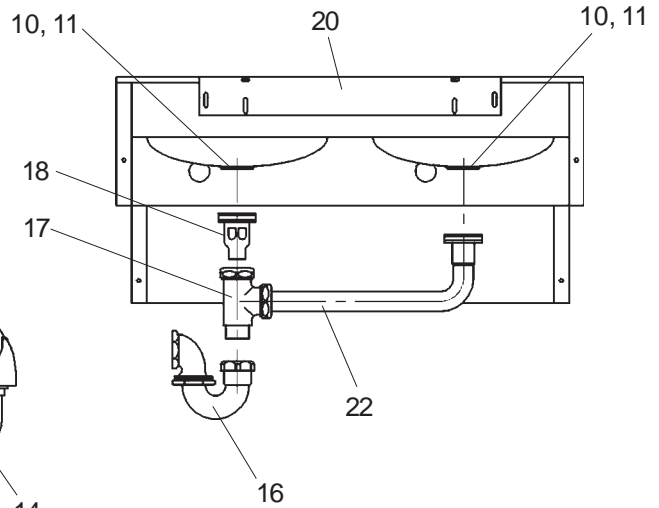
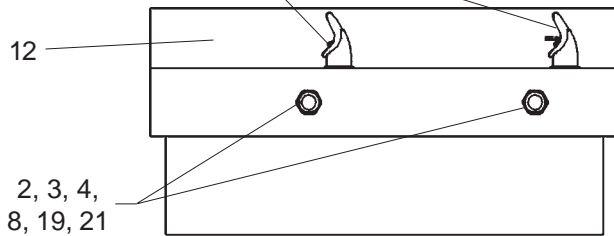

FIG. 4

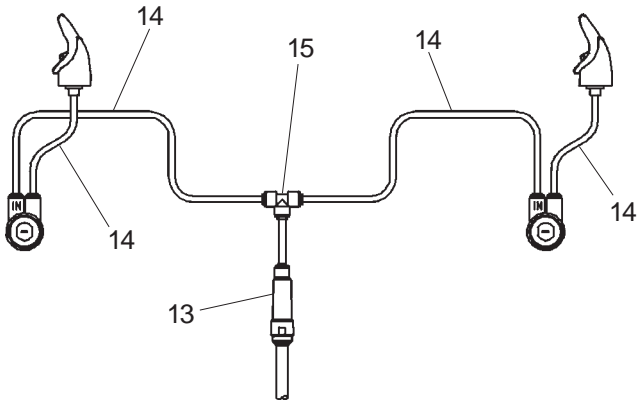
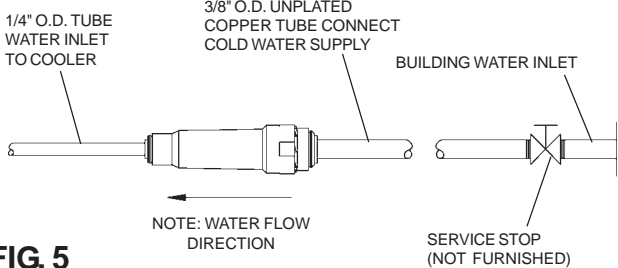

FIG. 5



OPERATION OF QUICK CONNECT FITTINGS

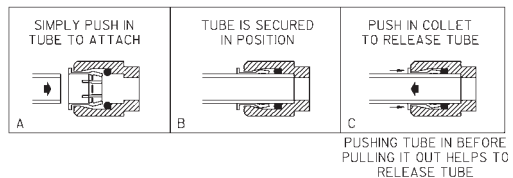

FIG. 6

EDF210C / EDF310C FOUNTAIN

ITEMIZED PARTS LIST

ITEM NO.	PART NO.	DESCRIPTION
1	56073C	Bubbler Assy.
2	40169C	Hex Nut
3	40048C	Button
4	40089C	Cover
5	40322C	Orifice Assy.
6	56011C	Bubbler Housing
7	55997C	Pedestal
8	61313C	Regulator
9	75580C	Locking Nut
10	45336C	Strainer/Ferrule Assy.
11	50074C	Gasket - Tailpipe
12	28569C	Fountain
13	55996C	Strainer
14	56092C	Polytubing
15	70682C	Tee - 1/4
16	45852C	Trap Assy.
17	45853C	Wasteline Tee Assy. (Vertical)
18	45854C	Tailpipe
19	15005C	Regulator Retaining Nut
20	28580C	Hanger Bracket
21	50986C	Regulator Holder
22	45857C	Wasteline (J-Tube)
23	45858C	Wasteline (Straight)
24	45856C	Wasteline Tee Assy. (Horizontal)
25	28333C	Bottom Cover Plate
26	75701C	Machine Screw 1/4-20 x 1/2
27	75700C	Weld Nut 1/4-2 x 1 1/4 Long

TROUBLE SHOOTING AND MAINTENANCE

Orifice Assy: Mineral deposits on orifice can cause water flow to spurt or not regulate. Mineral deposits may be removed from the orifice with a small round file or small diameter wire. **CAUTION: DO NOT FILE OR CUT ORIFICE MATERIAL.**

Actuation of Quick Connect Water Fittings: Cooler is provided with lead-free connectors which utilize an o-ring water seal. To remove tubing from the fitting, relieve water pressure, push in on the gray collar while pulling on the tubing (see figure 6).

Bubbler Replacement: When installing replacement bubbler and pedestal, tighten nut (Item 9, figure 3) only to hold parts snug in position. **Do not overtighten.**

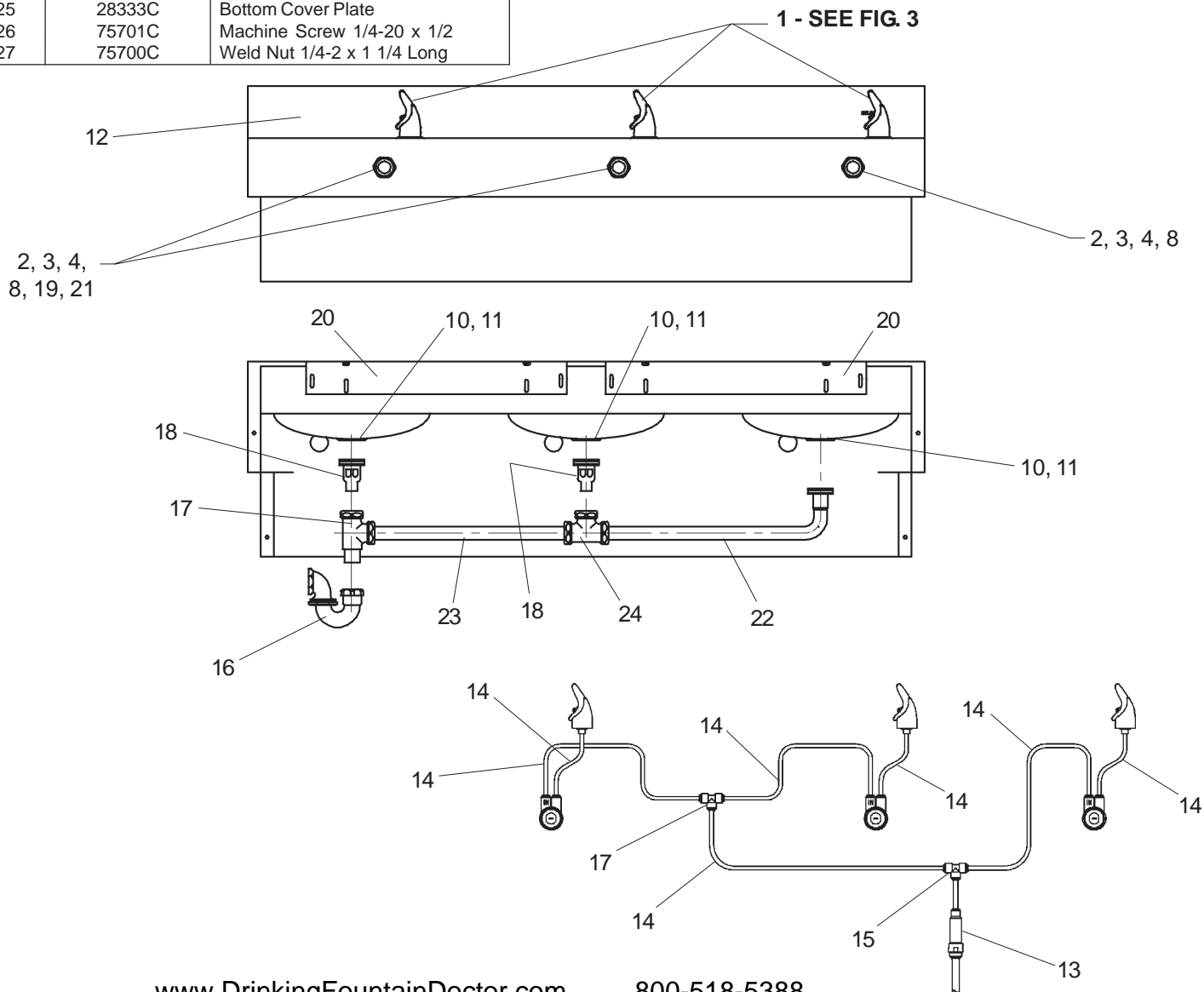

FIG. 7