

Installation/Care/Use Manual

USES HFC-134A REFRIGERANT

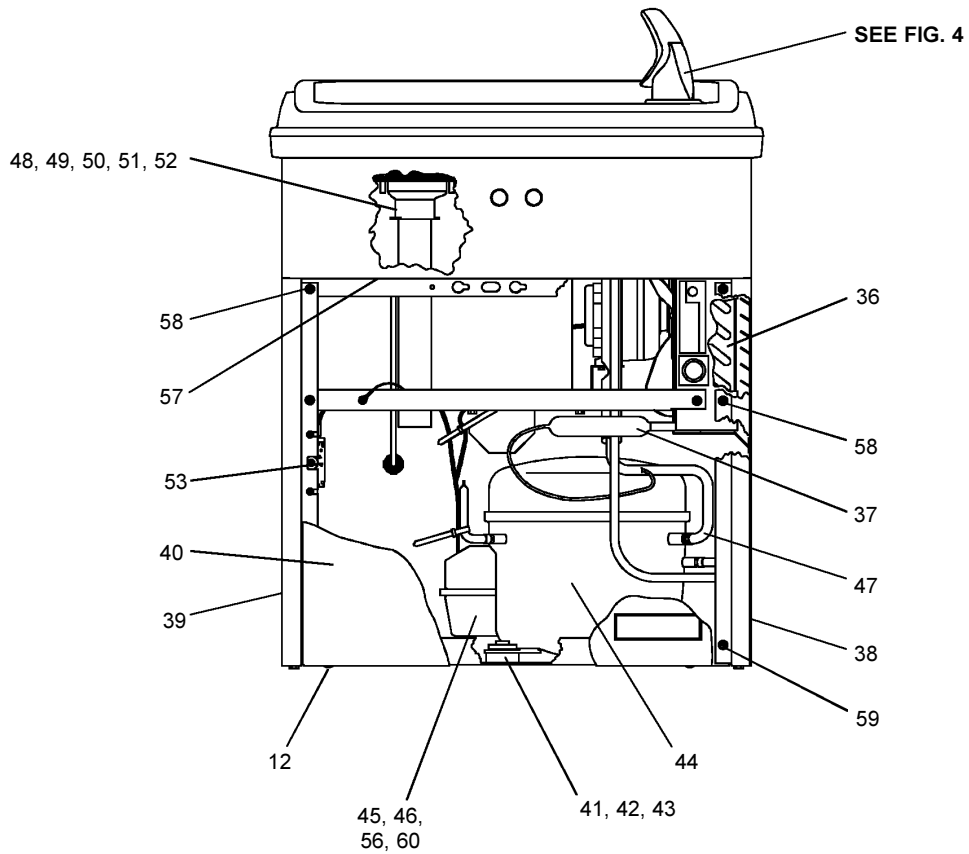
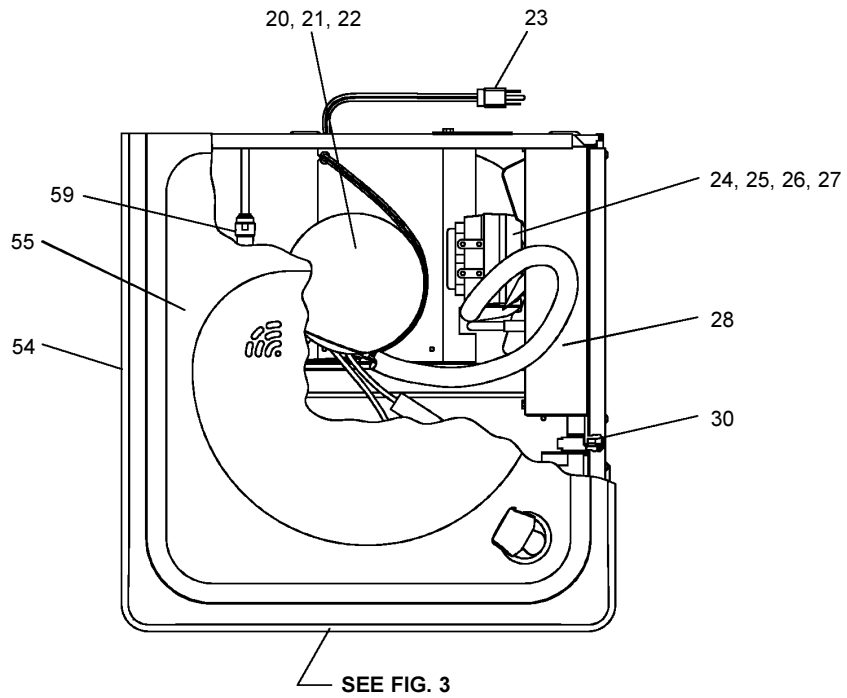

FIG. 1

SENSOR RANGE ADJUSTMENT: The electronic sensor used in this cooler is factory pre-set for a "visual" range of 36 inches (914 mm). If actual range varies greatly from this or a different setting is desired, follow the range adjustment procedure below:

- A. Remove front panel of cooler.
- B. Using a small tip screwdriver, rotate range adjustment screw clockwise to increase range and counterclockwise to decrease range (See Fig. 3).

CAUTION: Complete range of sensor (24-28 inches/610-711mm) is only one turn of the adjusting screw.

- C. Replace front panel.

SENSOR CONTROL: If sensor fails to operate valve mechanism or operates erratically, check the following.

- A. Ensure there are no obstructions within a 40 inch (1016mm) radius in front of cooler.
- B. Check wire connections at the solenoid valve and sensor. **CAUTION:** Make sure unit is unplugged before checking any wiring.
- C. Ensure proper operation of solenoid valve. If there is an audible clicking sound yet no water flows, look for an obstruction in the valve itself or elsewhere in the water supply line.

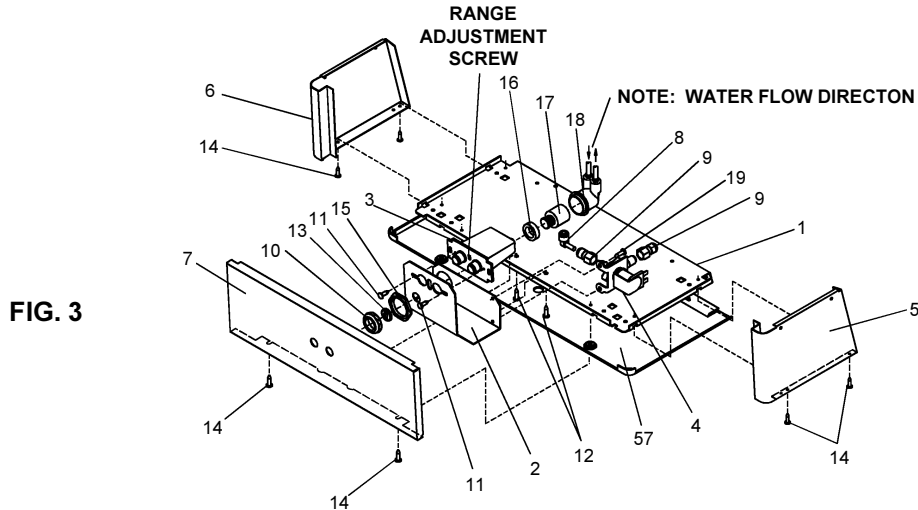

FIG. 3

HANGER BRACKETS & TRAP INSTALLATION

- 1) Remove hanger bracket fastened to back of cooler by removing one (1) screw.
- 2) Mount the hanger bracket and trap as shown in Figure 2. **NOTE:** Hanger Bracket **MUST** be supported securely. Add fixture support carrier if wall will not provide adequate support.

IMPORTANT:

- 7-3/4 in. (197mm) dimension from wall to centerline of trap must be maintained for proper fit.
- Anchor hanger securely to wall using all six (6) 1/4 in. dia. mounting holes.

- 3) Install straight valve for 3/8" O.D. tube.

INSTALLATION OF COOLER

- 4) Hang the cooler on the hanger bracket. Be certain the hanger bracket is engaged properly in the slots on the cooler back as shown in Figure 2.
- 5) Loosen the two (2) screws holding the lower front panel at the bottom of cooler base and two (2) screws at the top. Remove the front panel and set aside.
- 6) Connect water inlet line--See Note 4 of General Instructions.
- 7) Remove the slip nut and gasket from the trap and install them on the cooler waste line making sure that the end of the waste line fits into the trap. Assemble the slip nut and gasket to the trap and tighten securely.

START UP

Also See General Instructions

- 8) Stream height is factory set at 35 PSI. If supply pressure varies greatly from this, adjust screw, accessible by removing front panel (Item 7, Fig. 3). CW adjustment will raise stream and CCW adjustment will lower stream. For best adjustment, stream should hit basin approximately 6-1/2" (165mm) from bubbler.
- 9) Replace the front panel and secure by retightening four (4) screws.

ITEM NO.	PART NO.	DESCRIPTION
1	22897C	Panel-Bottom Dispenser
2	26729C	Bracket-Valve Mounting
3	31516C	Sensor-Clear (115V)
	35783C	Sensor-Clear (230V)
4	31272C	Solenoid Valve (115V)
	35784C	Solenoid Valve (230V)
5	See Color Table	Panel-Right Side
6	See Color Table	Panel-Left Side
7	See Color Table	Panel-Front
8	70817C	Elbow 1/4 Stem x 1/4 O.D.
9	75507C	Fitting 1/4 NPTF x 1/4 O.D.
10	40116C	Nut-Cover Unplated
11	70644C	Screw-#6-32 x 1/2" Lg. PHMS
12	75532C	Screw-#10 x 1/2" Lg. THSM
13	70254C	Clip
14	70864C	Screw-#8 x 5/8" Lg. Torx/Slot
15	40045C	Hex Nut
16	15005C	Retaining Nut
17	61314C	Regulator
18	50986C	Holder-Regulator
19	70002C	Screw-#10 x 1/2" Lg. HHSM

COLOR TABLE

PANEL COLOR	Item No. 5 Part No.	Item No. 6 Part No.	Item No. 7 Part No.
Bronzestone	27502C	27432C	27591C
Gray Beige	23015C	23008C	23161C
Almond	23016C	23009C	23162C
Stainless Stl	22822C	22814C	23137C
Sandalwood	23017C	23010C	23164C
Granite	23020C	23013C	27217C

PARTS LIST 115V

ITEM NO.	PART NO.	DESCRIPTION
20	62220C	Evaporator Assembly
21	70767C	Clip - Evap. Retaining
22	70772C	Plug - Drain
23	31483C	Power Cord
24, 24a	30699C	Fan Blade
24b	30664C	Fan Blade
25	70018C	Hex Nut - Fan Blade
26, 26a	31490C	Fan Motor 115V
26b	31491C	Fan Motor 115V
27	70009C	Screw - Fan Motor
28	22899C	Shroud - Fan
29	38417001	Screw - #8-18 x 3/8" Lg. (Fan Shroud)
30	75524C	Clip (Front and Rear Panels)
31	97276C	Bubbler Assembly Module
	97277C	Bubbler Assembly Module - Bronzestone
32	40322C	Orifice Assembly
	40066C	Orifice Assembly - Bronzestone
33	50934C	Guard
34	50168C	Pedestal
	50373C	Pedestal - Bronzestone
35	70012C	Locknut
36	62152C	Condenser
37	66202C	Drier
38	See Color Table	Panel - Right Rear
39	See Color Table	Panel - Left Rear
40	See Color Table	Panel - Front Lower
41	101516143550	Stud - Compressor Mtg.
42	100806740570	Grommet - Compressor Mtg.
43	19037000	Clip - Compressor Mtg.
44*	35767C	Compressor Serv. Pak FF7.5HBK
44a*	35761C	Compressor Serv. Pak FF6HBK
44b*	35807C	Compressor Serv. Pak AE3425Y
44c*	35947C	Compressor Serv. Pak EM65
45	31025C	Overload/Relay 1.350.358
45a	31026C	Overload/Relay 1.350.356
45b	35801C	Relay 9660-042-166
45b	35795C	Overload MRP26ALL-69
45c	31039C	Overload/Relay P600B/427NFBYY
46, 46a	35766C	Cover - Relay
46b	30181C	Cover - Terminal
46b	30180C	Overload Spring
46b	30182C	Bale Strap
46c	35768C	Cover - Relay
47, 47b	66214C	Heat Exchanger
47a	66215C	Heat Exchanger
47c	66386C	Heat Exchanger
48	40614C	Drain Tube
49	50400C	Gasket - Drain
50	50401C	Ring Support - Drain
51	70444C	Clamp - Drain Gasket
52	70016C	Hex Nut #10-32
53	31513C	Cold Control
54	See Color Table	Adaptor - Basin
55	MAD21874	Basin
	27534C	Basin - Bronzestone
56	194243901550	Cover - Electrical Shield
57	See Color Table	Cover-Dispenser Bottom
58	70002C	Screw-#10 x 1/2"Lg. HHSM
59	55996C	Strainer
60c	35935C	Capacitor - Run
NS	400660943730	Hanger Bracket

PARTS LIST 230V

ITEM NO.	PART NO.	DESCRIPTION
26	31431C	Fan Motor
44*	35763C	Compressor Serv. Pak
45	31024C	Overload/Relay
46	35768C	Cover-Relay

WIRING DIAGRAM

This Drawing is merely for illustrating the components of the electrical system.

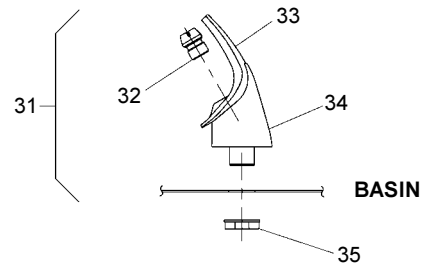
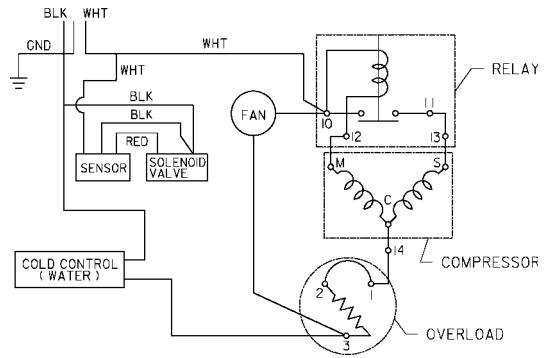

NOTE:
WHEN INSTALLING REPLACEMENT BUBBLER AND PEDESTAL, TIGHTEN NUT (ITEM 35) ONLY TO HOLD PARTS SNUG IN POSITION. DO NOT OVER TIGHTEN.

FIG. 4

*INCLUDES RELAY & OVERLOAD. IF UNDER WARRANTY, REPLACE WITH SAME COMPRESSOR USED IN ORIGINAL ASSEMBLY.

NOTE: All correspondence pertaining to any of the above water coolers or orders for repair parts MUST include Model No. and Serial No. of cooler, name and part number of replacement part.

CAUTION: Cleaning of Bronzestone Models requires special care. Outer surfaces must be cleaned with a mild detergent or mixture of vinegar and water only, rinsed and wiped dry. Abrasive and acidic cleaners may eventually damage the Bronzestone finish.

COLOR TABLE

PANEL COLOR	Item No. 38 Part No.	Item No. 39 Part No.	Item No. 40 Part No.	Item No. 54 Part No.	Item No. 57 Part No.
Bronzestone	27490C	27486C	27498C	51552C	55930C
Gray Beige	22967C	22960C	22953C	51551C	55931C
Almond	22968C	22961C	22954C	51552C	55930C
Stainless Steel	22862C	22854C	22955C	51551C	55931C
Sandalwood	22969C	22962C	22956C	51552C	55930C
Granite	22972C	22965C	27214C	51551C	55931C