

With FLEXI-GUARD®

Installation/Care/Use Manual

USES HFC-134A REFRIGERANT

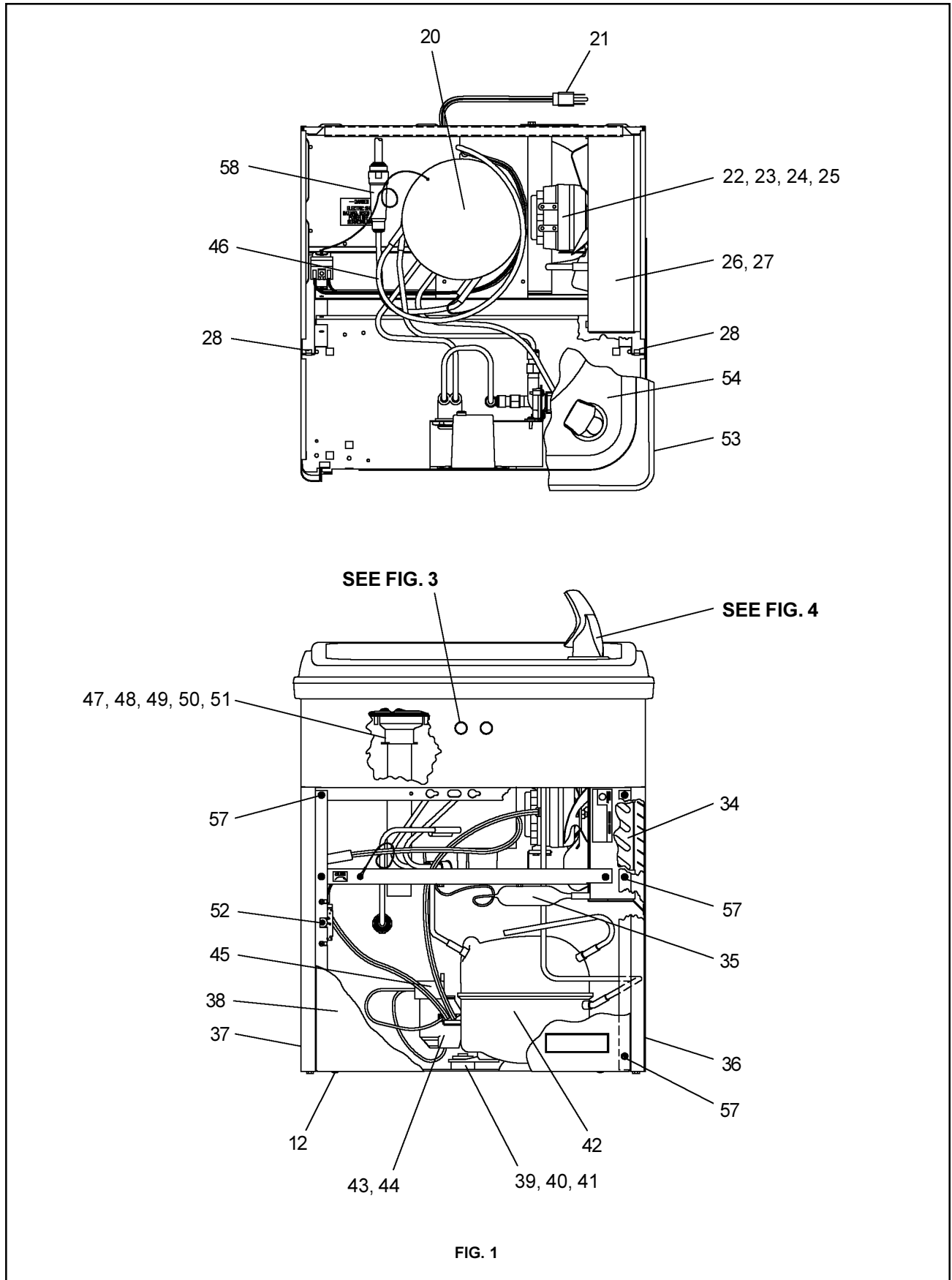

FIG. 1

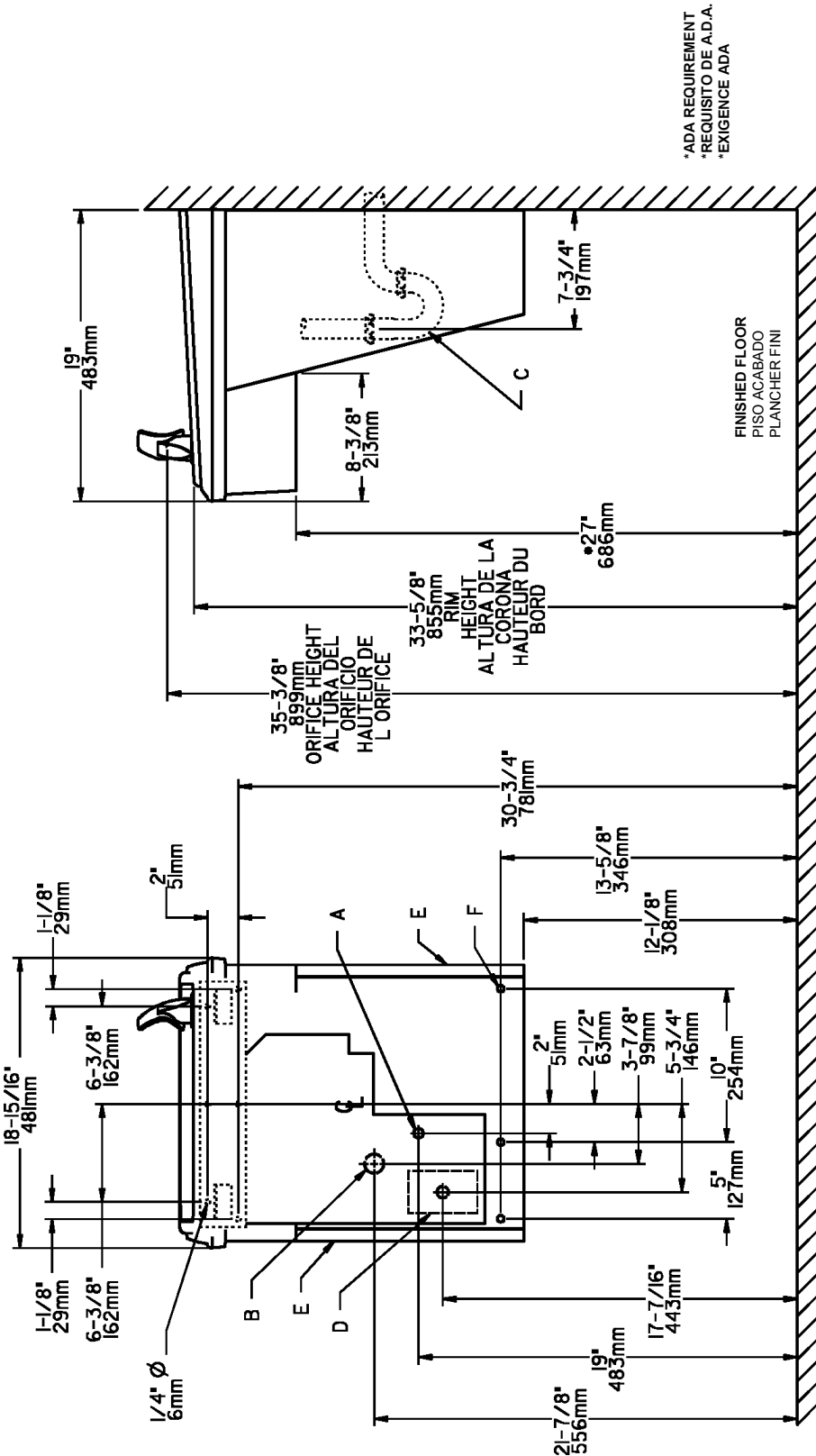

FIG. 2

D = ELECTRICAL SUPPLY (3) WIRE RECESSED BOX
 CAJAS RECESIVAS DE ALAMBRES (3) DE SUMINISTRO ELÉCTRICO
 BOITE ENCASTRÉE D'ALIMENTATION ÉLECTRIQUE (3) FILS
E = INSURE PROPER VENTILATION BY MAINTAINING 6" (152 mm) (MIN.) CLEARANCE FROM CABINET LOUVERS TO WALL.
 ASEGURE UNA VENTILACIÓN ADECUADA MANTENIENDO UN ESPACIO E 6" (152 mm) (MIN.) DE HOLGURA ENTRE LA REJILLA DE VENTILACIÓN DEL MUEBLE Y LA PARED
 ASSUREZ-VOUS UNE BONNE VENTILATION EN GARDANT 6" (152 mm) (MIN.) ENTRE LES ÉVÉNEMENTS DE L'ENCEINTE ET LE MUR.
F = 7/16 BOLT HOLES FOR FASTENING UNIT TO WALL
 AGUJEROS DE LAS TUERCAS DE 7/16 PARA SUJETAR LA UNIDAD A LA PARED
 TROUS D'ÉCROUS 7/16 POUR FIXER L'APPAREIL AU MUR

LEGEND/LEYENDA/LÉGENDE
A = RECOMMENDED WATER SUPPLY LOCATION 3/8 O.D. UNPLATED COPPER TUBE CONNECT STUB 1-1/2 IN. (38 mm) OUT FROM WALL SHUT OFF BY OTHERS
 SE RECOMIENDA UBICAR EL TUBO CORTO DE CONEXIÓN AL TUBO DE COBRE SIN CHAPAR DE 3/8" DE DIÁM. EXT. A 1-1/2" (38 mm) FUERA DE LA LLAVE DE PASO EN LA PARED COLOCADO POR TERCEROS.
B = RECOMMENDED LOCATION FOR WASTE OUTLET 1-1/4" O.D. DRAIN
 UBICACIÓN RECOMENDADA PARA EL DRENAJE DE SALIDA DE AGUA. DE 1 1/4" DE DIÁMETRO.
C = 1-1/4 TRAP NOT FURNISHED*
 PURGADOR DE 1 1/4" NO PROPORCIONADO**
 SIPHON 1-1/4" NON FOURNI**

SENSOR RANGE ADJUSTMENT: The electronic sensor used in this cooler is factory pre-set for a "visual" range of 36 inches (914 mm). If actual range varies greatly from this or a different setting is desired, follow the range adjustment procedure below:

- A. Remove front panel of cooler.
- B. Using a small tip screwdriver, rotate range adjustment screw clockwise to increase range and counterclockwise to decrease range (See Fig. 3).

CAUTION: Complete range of sensor (24-28 inches/610-711mm) is only one turn of the adjusting screw.

- C. Replace front panel.

SENSOR CONTROL: If sensor fails to operate valve mechanism or operates erratically, check the following.

- A. Ensure there are no obstructions within a 40 inch (1016mm) radius in front of cooler.
- B. Check wire connections at the solenoid valve and sensor. **CAUTION:** Make sure unit is unplugged before checking any wiring.
- C. Ensure proper operation of solenoid valve. If there is an audible clicking sound yet no water flows, look for an obstruction in the valve itself or elsewhere in the water supply line.

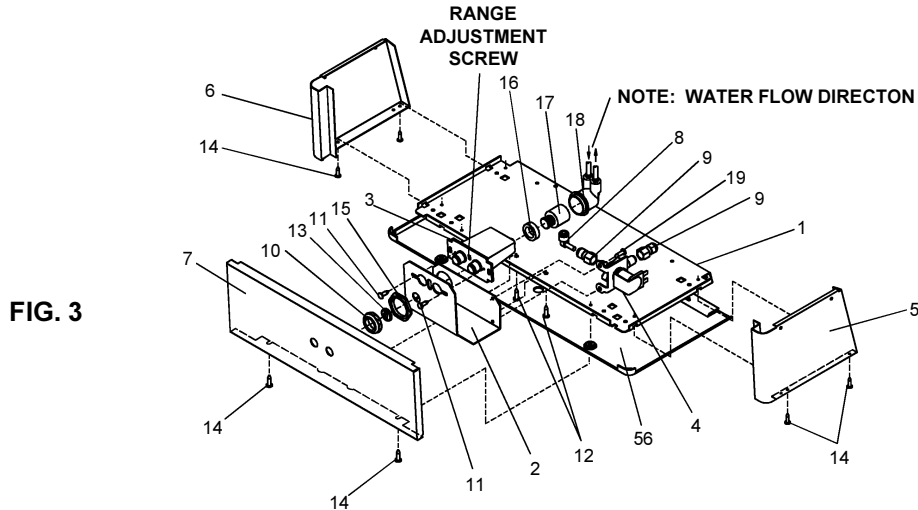

FIG. 3

HANGER BRACKETS & TRAP INSTALLATION

- 1) Remove hanger bracket fastened to back of cooler by removing one (1) screw.
- 2) Mount the hanger bracket and trap as shown in Figure 2. **NOTE:** Hanger Bracket **MUST** be supported securely. Add fixture support carrier if wall will not provide adequate support.

IMPORTANT:

- 7-3/4 in. (197mm) dimension from wall to centerline of trap must be maintained for proper fit.
- Anchor hanger securely to wall using all six (6) 1/4 in. dia. mounting holes.

- 3) Install straight valve for 3/8" O.D. tube.

INSTALLATION OF COOLER

- 4) Hang the cooler on the hanger bracket. Be certain the hanger bracket is engaged properly in the slots on the cooler back as shown in Figure 2.
- 5) Loosen the two (2) screws holding the lower front panel at the bottom of cooler base and two (2) screws at the top. Remove the front panel and set aside.
- 6) Connect water inlet line--See Note 4 of General Instructions.
- 7) Remove the slip nut and gasket from the trap and install them on the cooler waste line making sure that the end of the waste line fits into the trap. Assemble the slip nut and gasket to the trap and tighten securely.

START UP

Also See General Instructions

- 8) Stream height is factory set at 35 PSI. If supply pressure varies greatly from this, adjust screw, accessible by removing front panel (Item 7, Fig. 3). CW adjustment will raise stream and CCW adjustment will lower stream. For best adjustment, stream should hit basin approximately 6-1/2" (165mm) from bubbler.
- 9) Replace the front panel and secure by retightening four (4) screws.

ITEM NO.	PART NO.	DESCRIPTION
1	22897C	Panel-Bottom Dispenser
2	26729C	Bracket-Valve Mounting
3	31516C	Sensor-Clear (115V)
	35783C	Sensor-Clear (230V)
4	31272C	Solenoid Valve (115V)
	35784C	Solenoid Valve (230V)
5	See Color Table	Panel-Right Side
6	See Color Table	Panel-Left Side
7	See Color Table	Panel-Front
8	70817C	Elbow 1/4 Stem x 1/4 O.D.
9	75507C	Fitting 1/4 NPTF x 1/4 O.D.
10	40116C	Nut-Cover Unplated
11	70644C	Screw-#6-32 x 1/2" Lg. PHMS
12	75532C	Screw-#10 x 1/2" Lg. THSM
13	70254C	Clip
14	70864C	Screw-#8 x 5/8" Lg. Torx/Slot
15	40045C	Hex Nut
16	15005C	Retaining Nut
17	61314C	Regulator
18	50986C	Holder-Regulator
19	70002C	Screw-#10 x 1/2" Lg. HHSM

COLOR TABLE

PANEL COLOR	Item No. 5 Part No.	Item No. 6 Part No.	Item No. 7 Part No.
Bronzestone	27502C	27432C	27591C
Gray Beige	23015C	23008C	23161C
Almond	23016C	23009C	23162C
Stainless Stl	22822C	22814C	23137C
Sandalwood	23017C	23010C	23164C
Granite	23020C	23013C	27217C

PARTS LIST 115V

ITEM NO.	PART NO.	DESCRIPTION
20	66534C	Evaporator Assembly
21	31483C	Power Cord
22	30699C	Fan Blade
23	70018C	Hex Nut - Fan Blade
24	31490C	Fan Motor 115V
25	70009C	Screw - Fan Motor
26	22899C	Shroud - Fan
27	38417001	Screw - #8-18 x 3/8" Lg. (Fan Shroud)
28	75524C	Clip (Front and Rear Panels)
29	51349C	Bubbler Assembly
	51350C	Bubbler Assembly - Bronzestone
30	40322C	Orifice Assembly
	40066C	Orifice Assembly - Bronzestone
31	50934C	Guard
32	50168C	Pedestal
	50373C	Pedestal - Bronzestone
33	70012C	Locknut
34	62152C	Condenser
35	66202C	Drier
36	See Color Table	Panel -Right Rear
37	See Color Table	Panel -Left Rear
38	See Color Table	Panel - Front Lower
39	101516143550	Stud - Compressor Mtg.
40	100806740570	Grommet - Compressor Mtg.
41	19037000	Clip - Compressor Mtg.
42*	35947C	Compressor Serv. Pak EM65
43	31039C	Overload/Relay P600B/427NFBYY
44	35768C	Cover - Relay
45	35935C	Capacitor - Run
46	66386C	Heat Exchanger
47	40614C	Drain Tube
48	50400C	Gasket - Drain
49	50401C	Ring Support - Drain
50	70444C	Clamp - Drain Gasket
51	70016C	Hex Nut #10-32
52	31513C	Cold Control
53	See Color Table	Adaptor - Basin
54	21903C	Basin
55	27534C	Basin - Bronzestone
56	See Color Table	Cover-Dispenser Bottom
57	70002C	Screw-#10 x 1/2"Lg. HHSM
58	55996C	Strainer
NS	400660943730	Hanger Bracket

*INCLUDES RELAY & OVERLOAD. IF UNDER WARRANTY, REPLACE WITH SAME COMPRESSOR USED IN ORIGINAL ASSEMBLY.
 NOTE: All correspondence pertaining to any of the above water coolers or orders for repair parts MUST include Model No. and Serial No. of cooler, name and part number of replacement part.

CAUTION: Cleaning of Bronzestone Models requires special care. Outer surfaces must be cleaned with a mild detergent or mixture of vinegar and water only, rinsed and wiped dry. Abrasive and acidic cleaners may eventually damage the Bronzestone finish.

PARTS LIST 230V

ITEM NO.	PART NO.	DESCRIPTION
24	31431C	Fan Motor
42*	35763C	Compressor Serv. Pak
43	31024C	Overload/Relay
44	35768C	Cover-Relay
-	194243901550	Cover-Elect Shield

WIRING DIAGRAM

This Drawing is merely for illustrating the components of the electrical system.

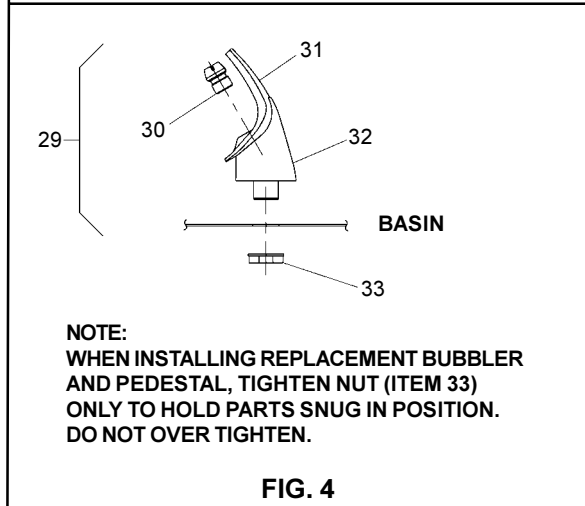
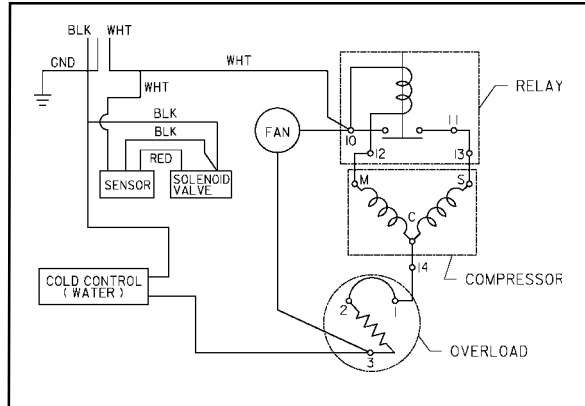

NOTE:
 WHEN INSTALLING REPLACEMENT BUBBLER AND PEDESTAL, TIGHTEN NUT (ITEM 33) ONLY TO HOLD PARTS SNUG IN POSITION. DO NOT OVER TIGHTEN.

FIG. 4

COLOR TABLE

PANEL COLOR	Item No. 36 Part No.	Item No. 37 Part No.	Item No. 38 Part No.	Item No. 53 Part No.	Item No. 56 Part No.
Bronzestone	27490C	27486C	27498C	51552C	55930C
Gray Beige	22967C	22960C	22953C	51551C	55931C
Almond	22968C	22961C	22954C	51552C	55930C
Stainless Steel	22862C	22854C	22955C	51551C	55931C
Sandalwood	22969C	22962C	22956C	51552C	55930C
Granite	22972C	22965C	27214C	51551C	55931C