

# Installation/Care/Use Manual

## Square Front® Refrigerated Fountains with FLEXI-GUARD®

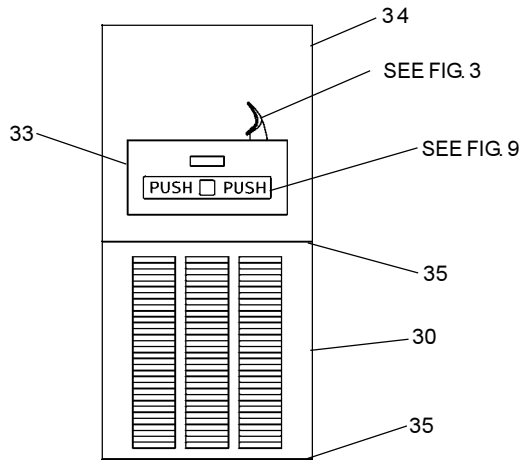

### Installer

To assure you install this model easily and correctly, PLEASE READ THESE SIMPLE INSTRUCTIONS BEFORE STARTING THE INSTALLATION. CHECK YOUR INSTALLATION FOR COMPLIANCE WITH PLUMBING, ELECTRICAL AND OTHER APPLICABLE CODES. After installation, leave these instructions inside the fountain for future reference.

### IMPORTANT

ALL SERVICE TO BE PERFORMED BY AN AUTHORIZED SERVICE PERSON

### IMPORTANT! INSTALLER PLEASE NOTE.

THE GROUNDING OF ELECTRICAL EQUIPMENT SUCH AS TELEPHONE, COMPUTERS, ETC. TO WATER LINES IS A COMMON PROCEDURE. THIS GROUNDING MAY BE IN THE BUILDING OR MAY OCCUR AWAY FROM THE BUILDING. THIS GROUNDING CAN CAUSE ELECTRICAL FEEDBACK INTO A FOUNTAIN, CREATING AN ELECTROLYSIS WHICH CAUSES A METALLIC TASTE OR AN INCREASE IN THE METAL CONTENT OF THE WATER. THIS CONDITION IS AVOIDABLE BY USING THE PROPER MATERIALS AS INDICATED. ANY DRAIN FITTINGS PROVIDED BY THE INSTALLER SHOULD BE MADE OF PLASTIC TO ELECTRICALLY ISOLATE THE FOUNTAIN FROM THE BUILDING PLUMBING SYSTEM.

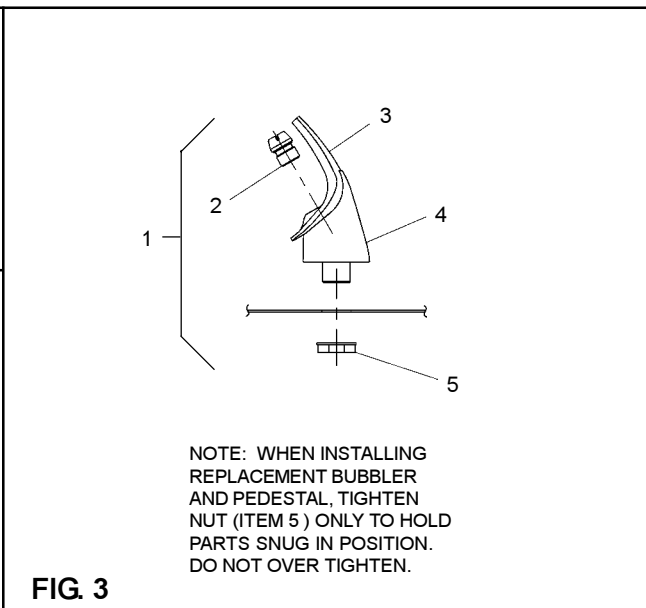
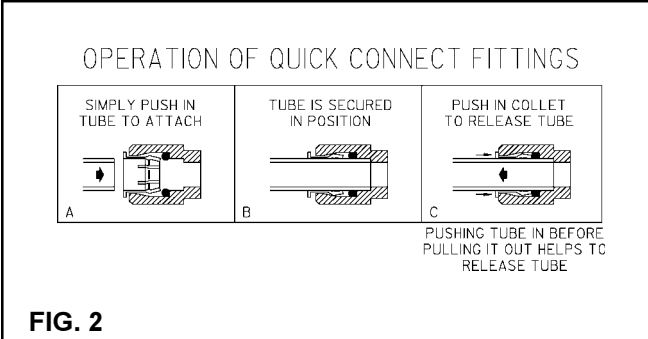
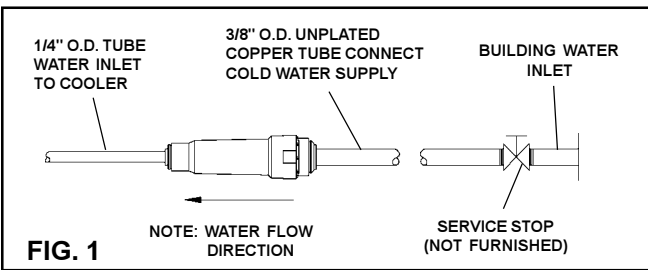

**MODEL LKFEA8C**

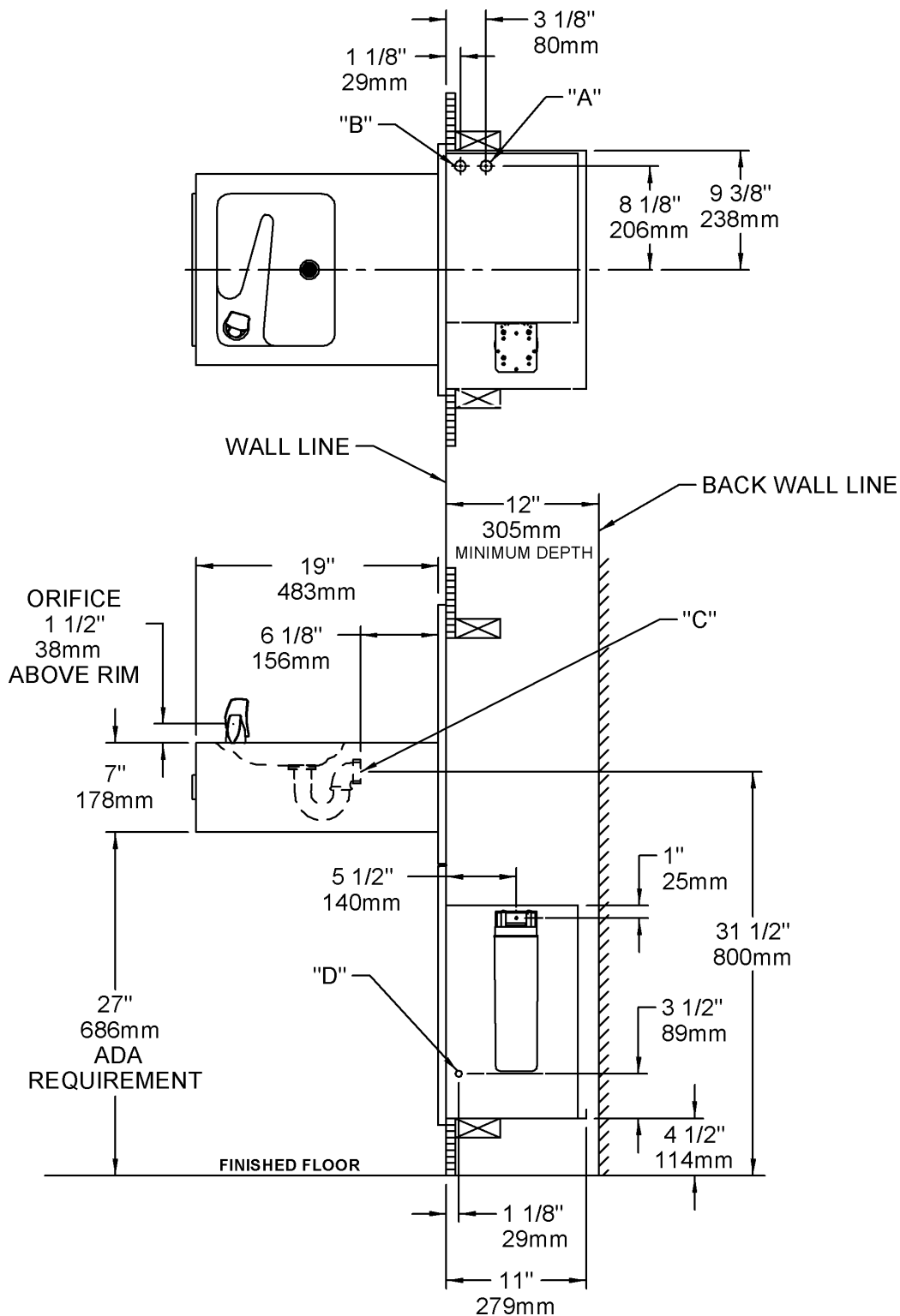

**LEGEND**

- A = 1/4" O.D. TUBE CONNECT (CHILLER WATER OUTLET)
- B = 3/8" O.D. TUBE CONNECT (CHILLER WATER INLET) SHUT OFF VALVE BY OTHERS
- C = 1-1/4" TRAP FURNISHED
- D = ELECTRICAL INLET

**FIG. 4**

## INSTALLATION INSTRUCTIONS

1. **Install** remote chiller. Remove front panel of chiller. Remove and discard cardboard inner pack from between compressor and side panel. Slide chiller onto the shelf and position it to the left side of shelf. (See Figure 4)  
**NOTE:** Building construction must allow for adequate air flow on both sides, top, and back of chiller. See chiller instructions for additional instructions.
2. **Make** water supply connections. Install a shut-off valve and union connection to building water supply (valve and union not provided). Turn on the water supply and flush the line thoroughly.
3. **ERHPA MODELS:** Make connection between remote chiller and building supply line. Inlet port is marked on the chiller (1/4" O.D. copper tube). Bend the copper tube (provided) at an appropriate length from chiller to opening in frame. Install the in-line strainer (provided with chiller) by pushing it in until it reaches a positive stop, approximately 3/4" (19mm) on the marked chiller inlet port. Connect building supply line to strainer. **DO NOT SOLDER TUBES INSERTED INTO THE STRAINER AS DAMAGE TO THE O-RINGS MAY RESULT.** (See Figure 5).  
**LKFEA MODEL:** Mount filter head assembly to side of chiller (See Figure 7). Make connection between filter and building supply line (3/8" O.D. tube not provided). Inlet port is marked on the chiller (1/4" O.D. copper tube). Install a 1/4" x 1/4" union (provided). Bend the copper tube (provided) at an appropriate length from the filter and connect to the union on the chiller. **DO NOT SOLDER TUBES INSERTED INTO THE UNION AS DAMAGE TO THE O-RINGS MAY RESULT.** (See Figure 6).
4. **Hang** the upper panel on the mounting frame hanger. Align holes in the panel with the holes in the mounting frame. Be sure that panel is engaged with hanger at top of frame before releasing it.
5. **Install** the fountain. Mount the fountain to the upper panel and the wall frame with (4) 1/4" x 3/4" (19mm) long bolts and nuts (provided). Tighten securely.
6. **Remove** elbow from end of p-trap and attach it to drain tube. Re-attach elbow to p-trap and cut waste tube to required length using plumbing hardware and trap as a guide.
7. **ERHPA MODELS:** Make connections between remote chiller outlet tube and fountain. Outlet port is marked on the chiller (1/4" O.D. copper tube). Install a 1/4" x 1/4" union (provided) on the marked chiller outlet port. Insert the 1/4" poly tubing coming from the fountain into the union. Turn on water supply and check for leaks. **DO NOT SOLDER TUBES INSERTED INTO THE UNION AS DAMAGE TO THE O-RINGS MAY RESULT.** (See Figure 5).  
**LKFEA MODEL:** Make connections between remote chiller outlet tube and fountain. Outlet port is marked on the chiller (1/4" O.D. copper tube). Install a 1/4" x 1/4" union (provided) on the marked chiller outlet port. Insert the 1/4" poly tubing coming from the fountain into the union. Turn on water supply and check for leaks. **DO NOT SOLDER TUBES INSERTED INTO THE UNION AS DAMAGE TO THE O-RINGS MAY RESULT.** (See Figure 6).
8. **These** products are designed to operate on 20-105 PSIG supply line pressure. If inlet pressure is above 105 PSIG, a pressure regulator must be installed in the supply line. Any damage caused by reason of connecting these products to supply line pressures lower than 20 PSIG or higher than 105 PSIG is not covered by warranty.
9. **Make** electrical connections to the chiller. See chiller instructions.
10. **Check** stream height from bubbler. Stream height is factory set at 35 PSI. If supply pressure varies greatly from this, turn adjustment screw on regulator (Item 12). Clockwise adjustment will raise stream height and counter-clockwise will lower stream height. For best adjustment stream should hit basin approximately 6 1/2" from the bubbler.
11. **Mount** lower panel. Loosen the (2) #10-24 x 5/8" (16mm) screws at frame bottom lip. Slide upper tongue of lower panel under lower edge of already installed upper panel. Tighten previously loosened screws securely.
12. **Replace** bottom access panel to fountain basin using screws provided. Tighten securely.

## TROUBLE SHOOTING AND MAINTENANCE

1. **Orifice Assy:** Mineral deposits on orifice can cause water flow to spurt or not regulate. Mineral deposits may be removed from orifice with a small round file not over 1/8" diameter or a small diameter wire. **CAUTION:** Do not file or cut orifice materials.
2. **Stream Regulator:** If orifice is free of material deposits, regulate flow according to instruction 10 stated above.
3. **Actuation of Quick Connect Water Fittings:** Cooler is provided with lead-free connectors which utilize an o-ring water seal. To remove tubing from the fitting, relieve water pressure, push in on the gray collar while pulling on the tubing (See Fig. 2) To insert tubing, push tube straight into the fitting until it reaches a positive stop, approximately 3/4".

### ERHPA8C TUBE ROUTING

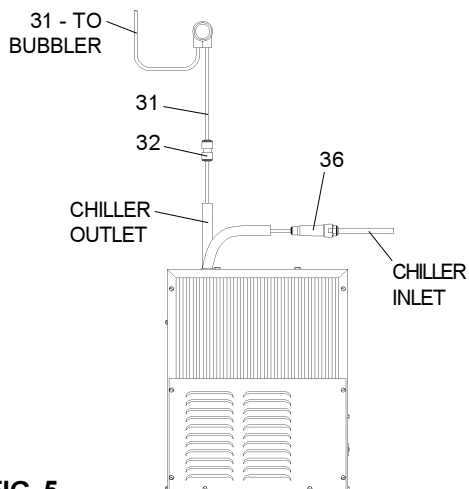

**FIG. 5**

### LKFEA8C TUBE ROUTING

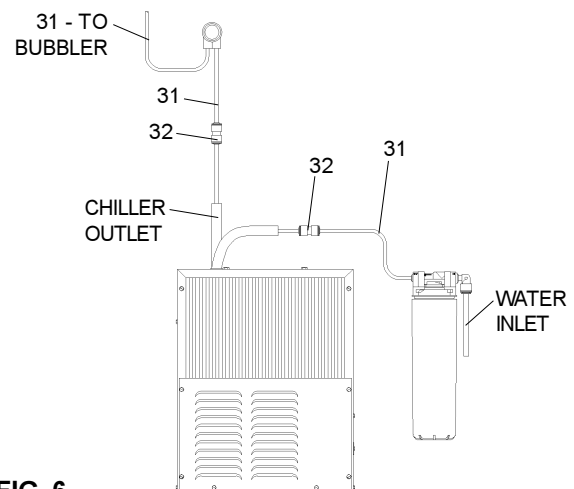

**FIG. 6**

ERHPA8C\*A LKFEA8C\*A

| PARTS LIST |              |                                 |
|------------|--------------|---------------------------------|
| ITEM NO.   | PART NO.     | DESCRIPTION                     |
| 1          | 56073C       | Bubbler Assembly                |
| 2          | 40322C       | Orifice Assembly                |
| 3          | 56011C       | Housing Assembly                |
| 4          | 55997C       | Pedestal                        |
| 5          | 75580C       | Bubbler Locknut                 |
| 6          | 21696C       | Bracket - Push Bar Mounting     |
| 7          | 21708C       | Push Bar Assembly               |
| 8          | 112627543890 | Screw - #10-24 x .50 PHTC       |
| 9          | 21695C       | Lever - Push                    |
| 10         | 50986C       | Holder-Regulator                |
| 11         | 40045C       | Hex Nut                         |
| 12         | 61314C       | Regulator                       |
| 13         | 15005C       | Retaining Nut                   |
| 14         | 75555C       | Clip                            |
| 15         | 50198C       | Bushing - Nylon                 |
| 16         | 70379C       | Rod - Pivot                     |
| 17         | 70278C       | Rod - Pivot                     |
| 18         | 70378C       | Rod - Push                      |
| 19         | 21705C       | Clip - Push Rod                 |
| 20         | 70002C       | Screw - #10 X .50 HHSM          |
| 21         | 40206000     | Retainer                        |
| 22         | 70023C       | Set Screw                       |
| 23         | 22490C       | Filter Mounting Bracket         |
| 24         | 51294C       | Filter Head Assy                |
| 25         | 51299C       | Filter Assy                     |
| 26         | 70792C       | Screw - #8-18 x .75" PH         |
| 27         | 70818C       | Elbow - 3/8" (10mm)             |
| 28         | 70822C       | Fitting - Superseal 1/4" (6mm)  |
| 29         | 70823C       | Fitting - Superseal 3/8" (10mm) |
| 30         | 26833C       | Lower Panel                     |
| 31         | 56092C       | Poly Tubing (Cut To Length)     |
| 32         | 70683C       | Union - 1/4 X 1/4               |
| 33         | 55001083     | FTN Body Assembly               |
| 34         | 28189C       | Upper Panel                     |
| 35         | 111008343890 | Screw - #10-24 X .62 HHMS       |
| 36         | 55996C       | Strainer                        |
| NS         | 74070002     | Screw - 1/4-20 X .75 PHMS       |
| NS         | 70018C       | Nut- Hex 1/4-20                 |

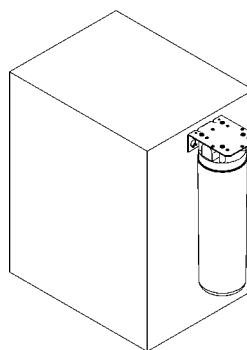

FIG. 7

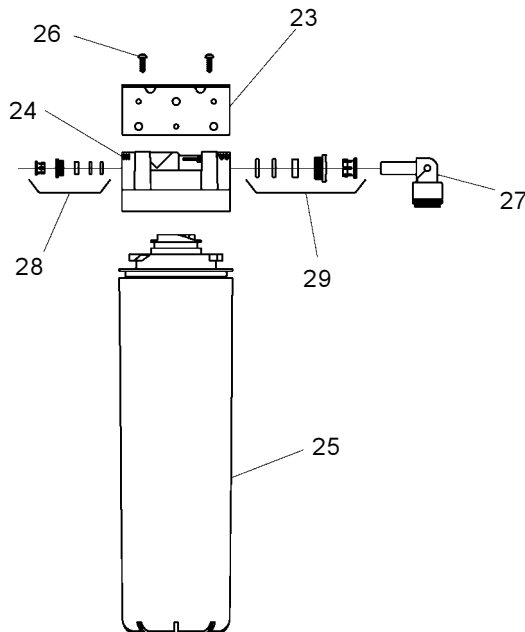

FIG. 8

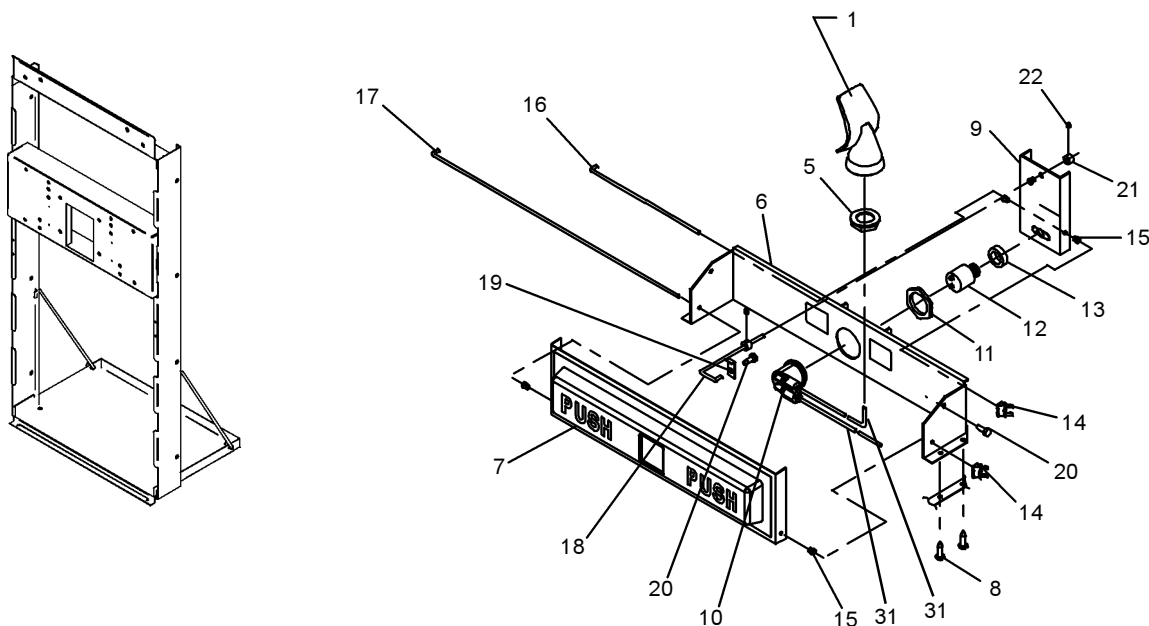

FIG. 9