

Installation/Care/Use Manual

SwirlFlo® Refrigerated Fountains with FLEXI-GUARD®

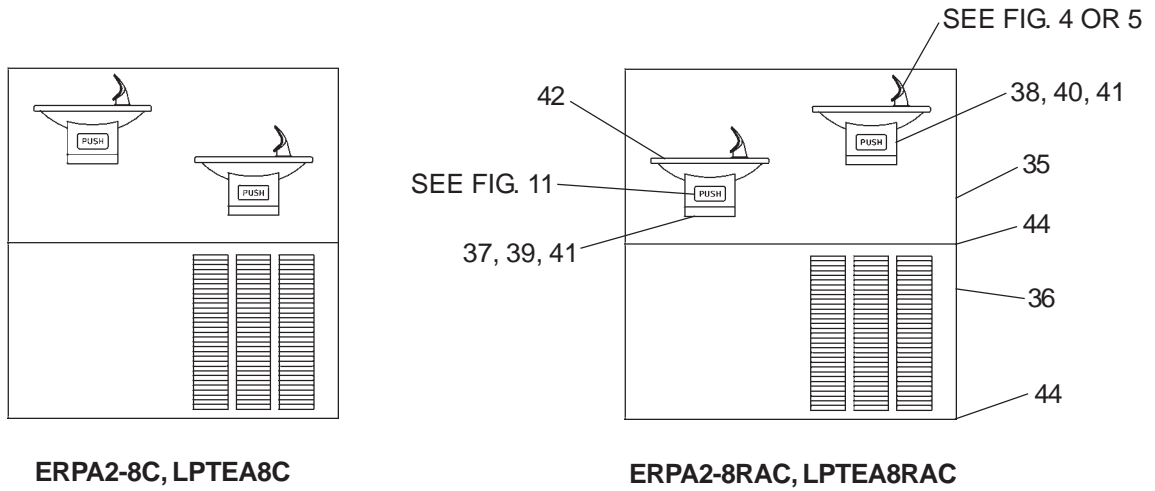

ERPA2-8C, LPTEA8C

ERPA2-8RAC, LPTEA8RAC

Installer

To assure you install this model easily and correctly, PLEASE READ THESE SIMPLE INSTRUCTIONS BEFORE STARTING THE INSTALLATION. CHECK YOUR INSTALLATION FOR COMPLIANCE WITH PLUMBING, ELECTRICAL AND OTHER APPLICABLE CODES. After installation, leave these instructions inside the fountain for future reference.

IMPORTANT

ALL SERVICE TO BE PERFORMED BY AN AUTHORIZED SERVICE PERSON

IMPORTANT! INSTALLER PLEASE NOTE.

THE GROUNDING OF ELECTRICAL EQUIPMENT SUCH AS TELEPHONE, COMPUTERS, ETC. TO WATER LINES IS A COMMON PROCEDURE. THIS GROUNDING MAY BE IN THE BUILDING OR MAY OCCUR AWAY FROM THE BUILDING. THIS GROUNDING CAN CAUSE ELECTRICAL FEEDBACK INTO A FOUNTAIN, CREATING AN ELECTROLYSIS WHICH CAUSES A METALLIC TASTE OR AN INCREASE IN THE METAL CONTENT OF THE WATER. THIS CONDITION IS AVOIDABLE BY USING THE PROPER MATERIALS AS INDICATED. ANY DRAIN FITTINGS PROVIDED BY THE INSTALLER SHOULD BE MADE OF PLASTIC TO ELECTRICALLY ISOLATE THE FOUNTAIN FROM THE BUILDING PLUMBING SYSTEM.

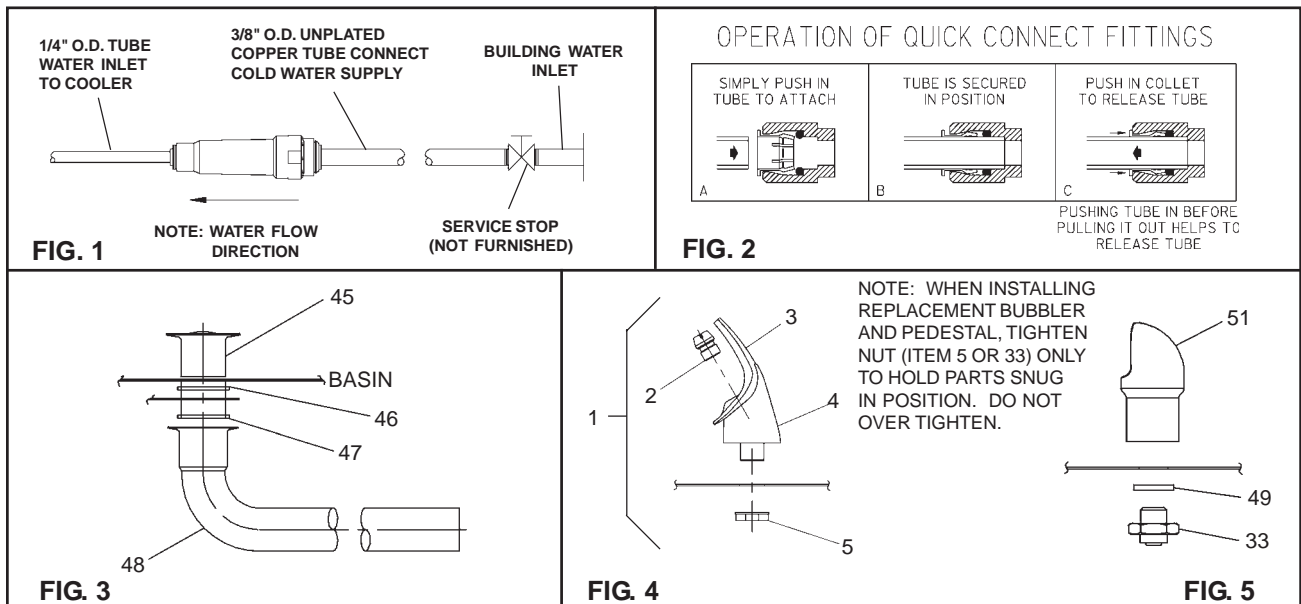

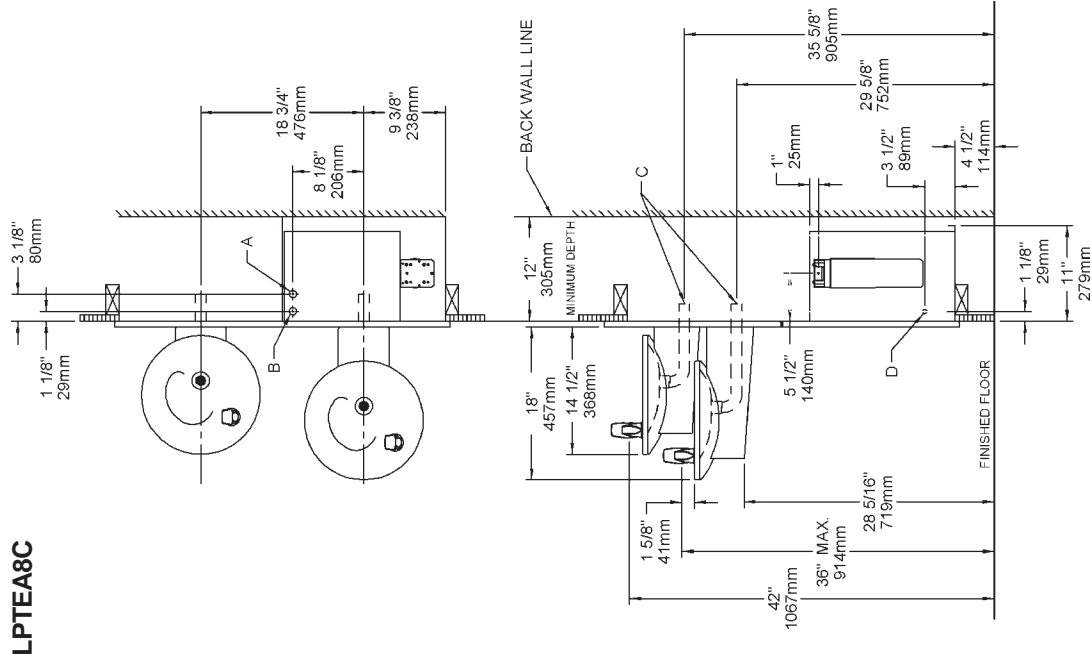
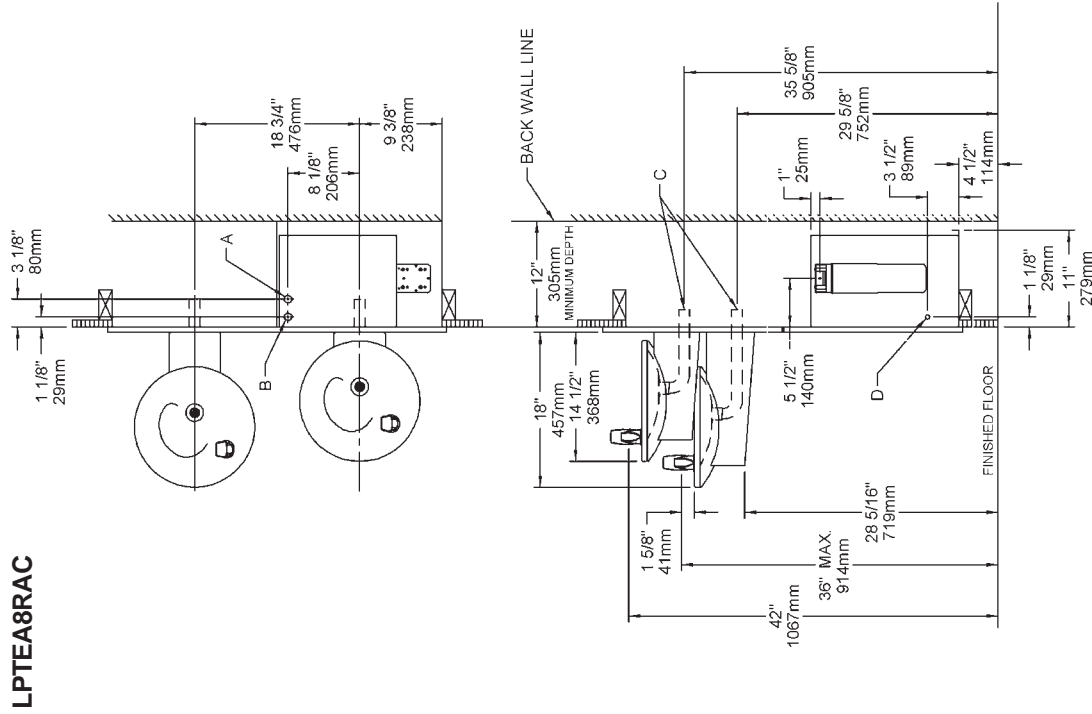

FIG. 6

LEGEND
 A = 1/4" O.D. TUBE CONNECT (CHILLER WATER OUTLET)
 B = 3/8" O.D. TUBE CONNECT (CHILLER WATER INLET) SHUT OFF VALVE BY OTHERS
 C = 1-1/4" TRAP NOT FURNISHED
 D = ELECTRICAL INLET

INSTALLATION INSTRUCTIONS

1. **Install** remote chiller. Remove front panel of chiller. Remove and discard cardboard inner pack from between compressor and side panel. Slide chiller onto the shelf and position it to the left side of shelf. (See Figure 6)
NOTE: Building construction must allow for adequate air flow on both sides, top, and back of chiller. See chiller instructions for additional instructions.
2. **Make** water supply connections. Install a shut-off valve and union connection to building water supply (valve and union not provided). Turn on the water supply and flush the line thoroughly.
3. **ERPA MODELS:** Make connection between remote chiller and building supply line. Inlet port is marked on the chiller (1/4" O.D. copper tube). Bend the copper tube (provided) at an appropriate length from chiller to opening in frame. Install the in-line strainer (provided with chiller) by pushing it in until it reaches a positive stop, approximately 3/4" (19mm) on the marked chiller inlet port. Connect building supply line to strainer. **DO NOT SOLDER TUBES INSERTED INTO THE STRAINER AS DAMAGE TO THE O-RINGS MAY RESULT.** (See Figure 7).
LPTEA MODEL: Mount filter head assembly to side of chiller (See Figure 9). Make connection between filter and building supply line (3/8" O.D. tube not provided). Inlet port is marked on the chiller (1/4" O.D. copper tube). Install a 1/4" x 1/4" union (provided) on the inlet port. Insert the 1/4" poly tubing (provided) into fitting on filter and connect to the union on the chiller. **DO NOT SOLDER TUBES INSERTED INTO THE UNIONS AS DAMAGE TO THE O-RINGS MAY RESULT.** (See Figure 8).
4. **Hang** the upper panel on the mounting frame hanger. Align holes in the panel with the holes in the mounting frame. Be sure that panel is engaged with hanger at top of frame before releasing it.
5. **Install** the fountain. Remove access cover plate on underside of fountains and save the screws. Mount the fountain to the upper panel and the wall frame with (4) 5/16" x 1 3/4" (44mm) long bolts and nuts (provided). Install spacers on bottom two bolts. Tighten securely.
6. **Attach** waste tube (1 1/4" OD) to 1 1/4" OD slip trap (provided by others).
7. **ERPA MODELS:** Make connections between remote chiller outlet tube and fountains. Outlet port is marked on the chiller (1/4" O.D. copper tube). Install a 1/4" tee (provided) on the marked chiller outlet port. Insert the 1/4" poly tubing coming from the fountains into the tee. Turn on water supply and check for leaks. **DO NOT SOLDER TUBES INSERTED INTO THE TEE AS DAMAGE TO THE O-RINGS MAY RESULT.** (See Figure 7).
LPTEA MODEL: Make connections between remote chiller and fountains. Outlet port is marked on the chiller (1/4" O.D. copper tube). Install a 1/4" tee (provided) on the marked chiller outlet port. Insert the 1/4" poly tubing coming from the fountains into the tee. Turn on water supply and check for leaks. **DO NOT SOLDER TUBES INSERTED INTO THE TEE AS DAMAGE TO THE O-RINGS MAY RESULT.** (See Figure 8).
8. **These** products are designed to operate on 20-105 PSIG supply line pressure. If inlet pressure is above 105 PSIG, a pressure regulator must be installed in the supply line. Any damage caused by reason of connecting these products to supply line pressures lower than 20 PSIG or higher than 105 PSIG is not covered by warranty.
9. **Make** electrical connections to the chiller. See chiller instructions.
10. **Check** stream height from bubbler. Stream height is factory set at 35 PSI. If supply pressure varies greatly from this, turn adjustment screw on regulator (Item 12). Clockwise adjustment will raise stream height and counter-clockwise will lower stream height. For best adjustment stream should hit basin approximately 6 1/2" from the bubbler.
11. **Mount** lower panel. Loosen the (2) #10-24 x 5/8" (16mm) screws at frame bottom lip. Slide upper tongue of lower panel under lower edge of already installed upper panel. Tighten previously loosened screws securely.
12. **Replace** bottom access panel to fountain basin using screws provided. Tighten securely.

TROUBLE SHOOTING AND MAINTENANCE

1. **Orifice Assy:** Mineral deposits on orifice can cause water flow to spurt or not regulate. Mineral deposits may be removed from orifice with a small round file not over 1/8" diameter or a small diameter wire. **CAUTION:** Do not file or cut orifice materials.
2. **Stream Regulator:** If orifice is free of material deposits, regulate flow according to instruction 10 stated above.
3. **Actuation of Quick Connect Water Fittings:** Cooler is provided with lead-free connectors which utilize an o-ring water seal. To remove tubing from the fitting, relieve water pressure, push in on the gray collar while pulling on the tubing (See Fig. 2) To insert tubing, push tube straight into the fitting until it reaches a positive stop, approximately 3/4".
4. **Caution:** Cleaning of Bronzotone Models requires special care. Outer surfaces must be cleaned with a mild detergent or mixture of vinegar and water only, rinsed and wiped dry. Abrasive and acidic cleaners may eventually damage the Bronzotone finish.

ERPA2-8C/ERPA2-8RAC TUBE ROUTING

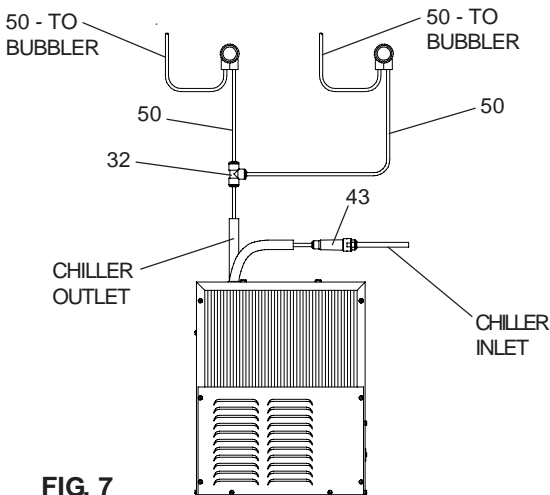

LPTEA8C/LPTEA8RAC TUBE ROUTING

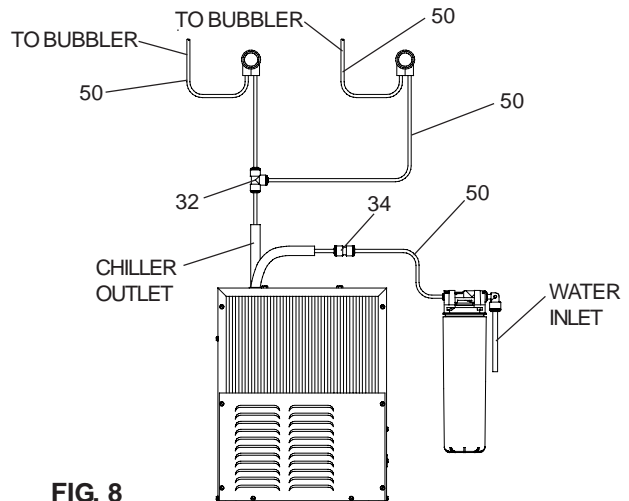

PARTS LIST

ITEM NO.	PART NO.	DESCRIPTION
1	56073C	Bubbler Assy
2	40322C	Orifice Assy
3	56011C	Housing Assembly
4	55997C	Pedestal
5	75580C	Bubbler Locknut
6	28322C	Push Bar Mounting Bracket
7	21810C	Push Bar Assy
8	28324C	Regulator Activator Arm
9	70426C	Screw - #8-32 X .25 THMS
10	50986C	Holder-Regulator
11	40045C	Hex Nut
12	61313C	Regulator
13	15005C	Retaining Nut
14	75555C	Clip
15	50198C	Bushing - Nylon
16	70410C	Rod - Pivot
17	70425C	Rod - Pivot
18	70378C	Rod - Push
19	21705C	Clip - Push Rod
20	70002C	Screw - #10 X .50 HHSM
21	28325C	Pivot Rod Bracket
22	40206000	Retainer
23	112627543890	Screw - #10-24 X .37 PHTC
24	22490C	Filter Mounting Bracket
25	51294C	Filter Head Assy
26	51299C	Filter Assy
27	28321C	Regulator Mounting Bracket
28	70792C	Screw - #8-18 x .75" PH
29	70818C	Elbow - 3/8" (10mm)
30	70822C	Fitting - Superseal 1/4" (6mm)
31	70823C	Fitting - Superseal 3/8" (10mm)
32	70682C	Tee - 1/4
33	15009C	Bubbler-Nipple-(VR Model Only)
34	70683C	Union - 1/4 X 1/4
35	28185C	Back Panel RH ADA
	28187C	Back Panel LH ADA
36	27026C	Lower Panel
37	21822C	Ftn Body & Shell-Short
38	21823C	Ftn Body & Shell-Long
39	21845C	Cover Plate-Short
40	21846C	Cover Plate-Long
41	70055C	Speed Nut
42	55001026	Basin-Swirlflow
43	55996C	Strainer
44	111008343890	Screw - #10-24 X .62 HHMS
45	45336C	Strainer & Ferrule Assembly
46	50074C	Gasket - Tailpipe
47	50377C	Gasket - Tailpipe
48	45330C	Waste Arm
49	100322740560	Gasket-(VR Model Only)
50	56092C	Poly Tubing (Cut To Length)
51	98118C	Bubbler Assembly (VR Model Only)
NS	70199C	Bolt - 5/16-18 x 1.75 Lg.
NS	70020C	Nut - Hex 5/16-18
NS	74080053	Spacer

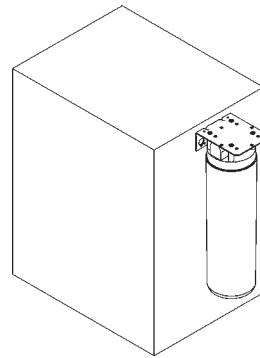

FIG. 9

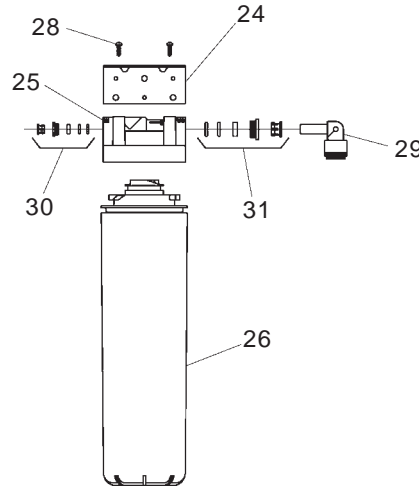

FIG. 10

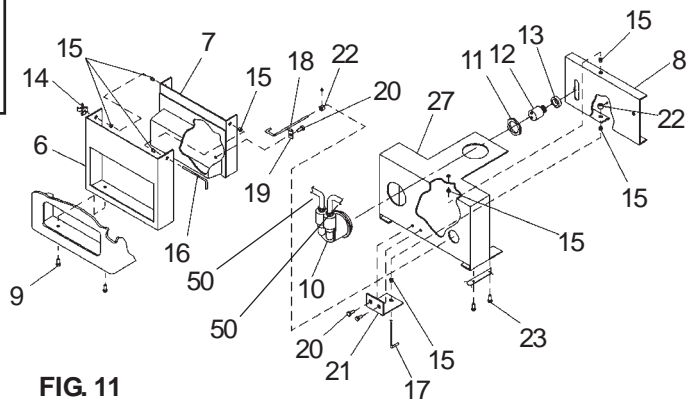
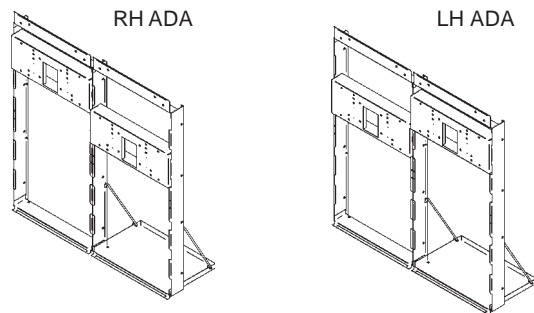

FIG. 11