

With FLEXI-GUARD[®]

Installation/Care/Use Manual

USES HFC-134A REFRIGERANT

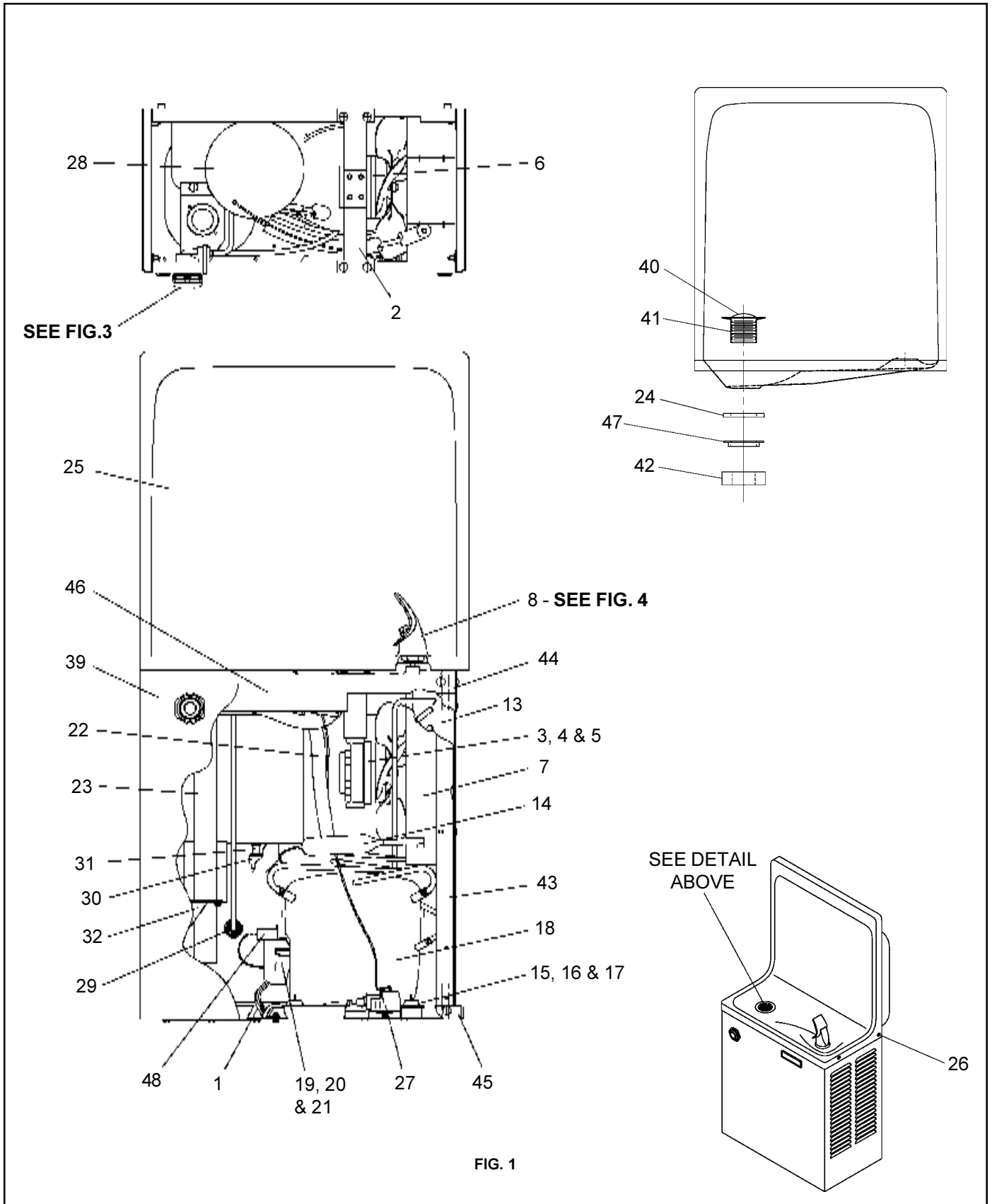

FIG. 1

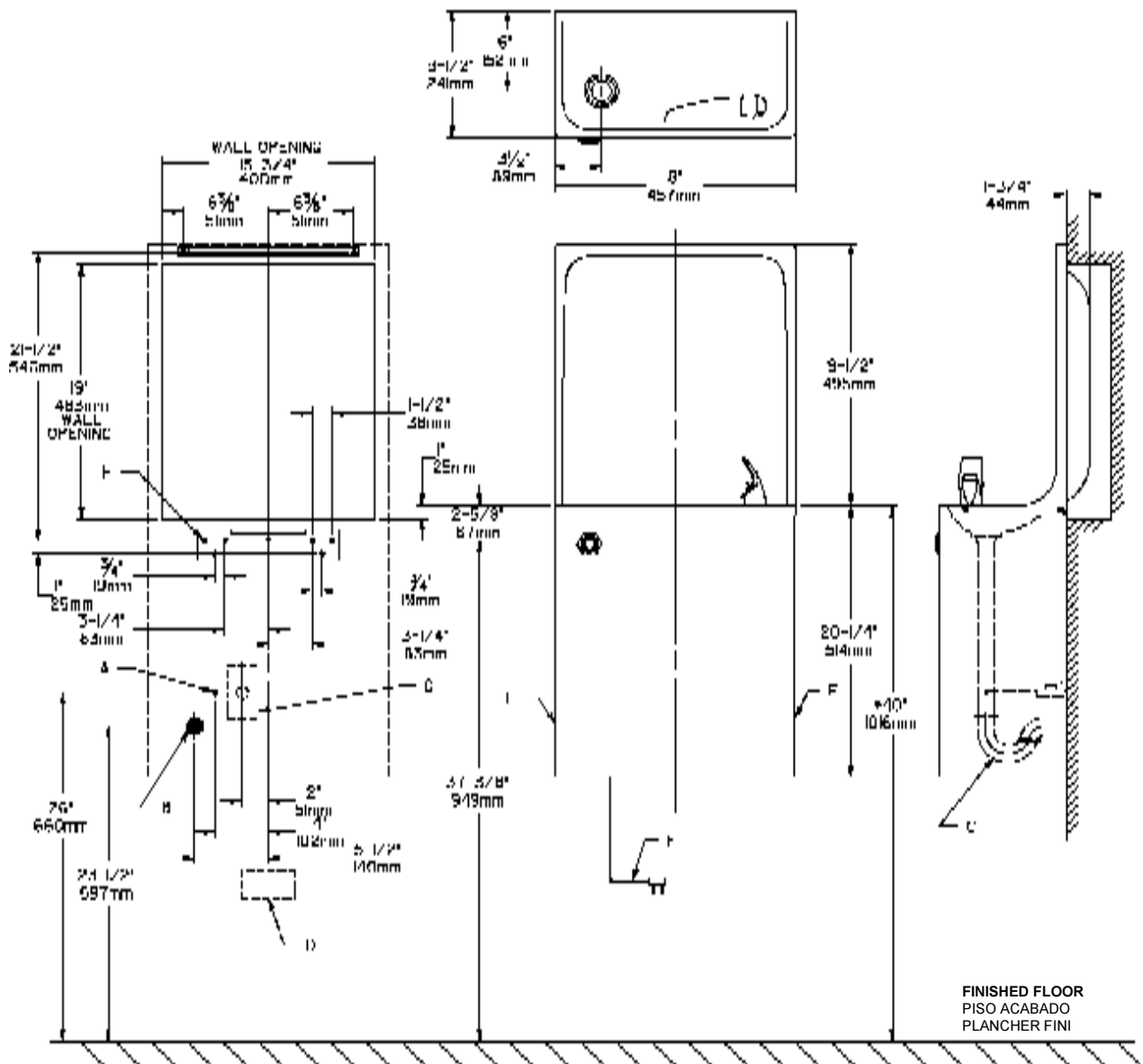

FIG. 2

* RECOMMENDED HEIGHT FOR ADULTS.
 DECREASE HEIGHT FOR CHILDREN.
 * ALTURA RECOMENDADA PARA ADULTOS.
 REDUZCA PARA LOS NIÑOS.
 * HAUTEUR RECOMMANDÉE POUR LES
 ADULTES. INSTALLEZ PLUS BAS POUR
 LES ENFANTS.

LEGEND/LEYENDA/LÉGENDE

- A = RECOMMENDED WATER SUPPLY LOCATION 3/8" O.D. UNPLATED COPPER TUBE CONNECT STUB 1-1/2" IN. (38 mm) OUT FROM WALL SHUT OFF BY OTHERS**
 SE RECOMIENDA UBICAR EL TUBO CORTO DE CONEXIÓN AL TUBO DE COBRE SIN CHAPAR DE 3/8" DE DIÁM. EXT. A 1-1/2" (38 mm) FUERA DE LA LLAVE DE PASO EN LA PARED COLOCADA POR TERCEROS.
 EMPLACEMENT RECOMMANDÉ D'ALIMENTATION EN EAU PAR TUBE EN CUIVRE NON PLAQUÉ DE 3/8 PO. (9.5 mm) D.E. CONNECTANT UNE TUYAUTERIE DE 1-1/2 PO. (38 mm) DEPUIS LE ROBINET D'ARRÊT FOURNI PAR D'AUTRES.
- B = RECOMMENDED LOCATION FOR WASTE OUTLET 1-1/4" O.D. DRAIN**
 UBICACIÓN RECOMENDADA PARA EL DRENAJE DE SALIDA DE AGUA, DE 1 1/4" DE DIÁMETRO.
 EMPLACEMENT RECOMMANDÉ POUR LE DRAIN DE D.E. 1-1/4" DE SORTIE D'EAU.
- C = 1-1/4" TRAP NOT FURNISHED****
 PURGADOR DE 1 1/4" NO PROPORCIONADO**
 SIPHON 1-1/4" NON FOURNI**
- D = ELECTRICAL OUTLET LOCATION**
 UBICACIÓN DE LA TOMA DE ELECTRICIDAD
 EMPLACEMENT DE LA PRISE DE COURANT
- E = INSURE PROPER VENTILATION BY MAINTAINING 4" (102mm) (MIN.) CLEARANCE FROM CABINET LOUVERS TO WALL.**
 ASEGURE UNA VENTILACIÓN ADECUADA MANTENIENDO UN ESPACIO 4" (102mm) (MÍN.) DE HOLGURA ENTRE LA REJILLA DE VENTILACIÓN DEL MUEBLE Y LA PARED
 ASSUREZ-VOUS UNE BONNE VENTILATION EN GARDANT 4" (102mm) (MÍN.) ENTRE LES ÉVENTS DE L'ENCEINTE ET LE MUR.
- F = POWER CORD 1-1/2 FEET (457mm) LONG**
 CABLE ELÉCTRICO DE 1 1/2 PIE, 457 mm DE LARGO
 CORDON D'ALIMENTATION 1-1/2' (457mm)
- G = ALT. ELECTRICAL OUTLET LOCATION**
 UBICACIÓN ALT. DE LA TOMA DE ELECTRICIDAD
 EMPLACEMENT ALTERNATIF DE LA PRISE DE COURANT
- H = 5/16" (8mm) SCREW HOLES IN MOUNTING PLATE**
 AGUJEROS DE TORNILLO 5/16" (8mm) EN LA PLACA DE MONTAJE
 TROUS DE VIS 5/16" (8mm) DANS LA PLAQUE DE MONTAGE

IMPORTANT
ALL SERVICE TO BE PERFORMED BY AN AUTHORIZED SERVICE PERSON

HANGER BRACKETS & TRAP INSTALLATION

- 1) Remove hanger brackets fastened to back of cooler by removing screws.
 - 2) Mount the hanger brackets and trap as shown in Figure 2.
- NOTE:** Hanger Brackets and trap **MUST** be supported securely. Add fixture support carrier if wall will not provide adequate support.
- IMPORTANT:**
- 5-1/2 in. (140mm) dimension from wall to centerline of trap must be maintained for proper fit.
 - Anchor hanger securely to wall using all mounting holes.
- 3) Install straight valve for 3/8" O.D. unplated copper tube.

INSTALLATION OF COOLER

- 4) Hang the cooler on the hanger brackets. Be certain the hanger brackets are engaged properly in the frame and wrapper.
- 5) Remove the access panel on the underside of the cooler and set it aside.
- 6) Connect water inlet line--See Note 4 of General Instructions.
- 7) Remove the slip nut and gasket from the trap and install them on the cooler waste line making sure that the end of the waste line fits into the trap. Assemble the slip nut and gasket to the trap and tighten securely.

START UP

Also See General Instructions

- 8) Replace the front panel and secure by retightening all screws.

Stream height is factory set at 35 PSI. If supply pressure varies greatly from this, remove items 33 & 34 and adjust screw on item 36. Clockwise adjustment will raise stream and counter-clockwise adjustment will lower stream. For best adjustment, stream should hit basin approximately 6-1/2" (165mm) from bubbler.

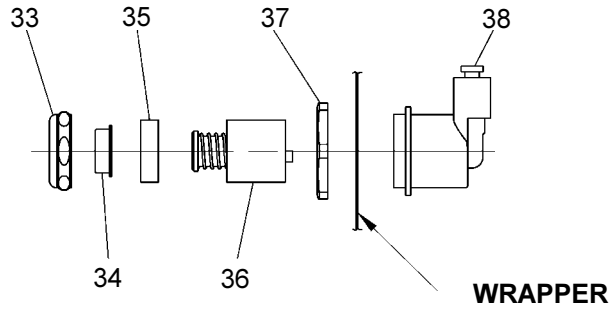

FIG. 3

NOTE:
 WHEN INSTALLING REPLACEMENT BUBBLER AND PEDESTAL, TIGHTEN NUT (ITEM 12) ONLY TO HOLD PARTS SNUG IN POSITION. DO NOT OVER TIGHTEN.

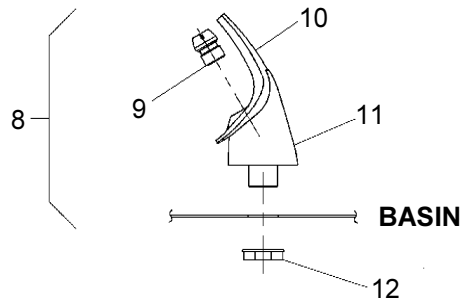

FIG. 4

PARTS LIST 115V

ITEM NO.	PART NO.	DESCRIPTION
1	31504C	Power Cord
2	27095C	Fan Bracket
3	30699C	Fan Blade
4	70018C	Hex Nut - Fan Blade
5	31490C	Fan Motor
6	70009C	Screw (Fan Motor)
7	50186C	Shroud - Fan
8	51349C	Bubbler Assy
9	40322C	Orifice Assy
10	50934C	Housing Assy
11	50168C	Pedestal
12	70012C	Locknut
13	62152C	Condenser
14	66202C	Drier
15	50144C	Grommet - Compressor Mtg.
16	70184C	Hair Pin - Cotter
17	70418C	Washer
18*	35767C	Compressor Serv. Pak FF7.5HBK
18a*	35947C	Compressor Serv. Pak EM65
19	194243901550	Cover - Electrical Shield (Overload)
20	31025C	Overload/Relay 1.350.358
20a	31039C	Overload/Relay P600B/427NFBYY
21	35766C	Cover - Relay
21a	35768C	Cover - Relay
22	66223C	Heat Exchanger
22a	66501C	Heat Exchanger
23	40041C	Tailpipe Assy (8 Gal)
23a	40429C	Precooler Assy (13 Gal)
24	50074C	Tailpipe Gasket
25	20593C	Basin - Stainless Steel
26	70208C	Screw - Basin Mtg.
27	31513C	Cold Control
28	62220C	Evaporator Assembly
29	55996C	Strainer
30	70772C	Drain Plug
31	70767C	Evaporator Retaining Clip
32	27239C	Bracket - Precooler
33	40089C	Cover
34	40048C	Button
35	15005C	Retaining Nut
36	61313C	Regulator
37	40169C	Hex Nut
38	50986C	Regulator Holder
39	See Color Table	Wrapper
40	40038C	Strainer - Beehive
41	40619C	Ferrule - Tailpipe
42	50105C	Tailpipe Gasket
43	27093C	Angle-Front Corner
44	27292C	Bracket-Basin Mounting
45	27097C	Frame-Back/Bottom
46	27258C	Bracket-Front
47	40043C	Locknut
48a	35935C	Capacitor - Run

*INCLUDES RELAY & OVERLOAD. IF UNDER WARRANTY, REPLACE WITH SAME COMPRESSOR USED IN ORIGINAL ASSEMBLY.

NOTE: All correspondence pertaining to any of the above water coolers or orders for repair parts MUST include Model No. and Serial No. of cooler, name and part number of replacement part.

COLOR TABLE	
PANEL COLOR	Item No. 39 Part No.
Gray Beige	21017C
Almond	21481C
Stainless Steel	21013C
Sandalwood	21480C
Granite	27208C