

# With FLEXI-GUARD®

## Installation/Care/Use Manual

USES HFC-134A REFRIGERANT

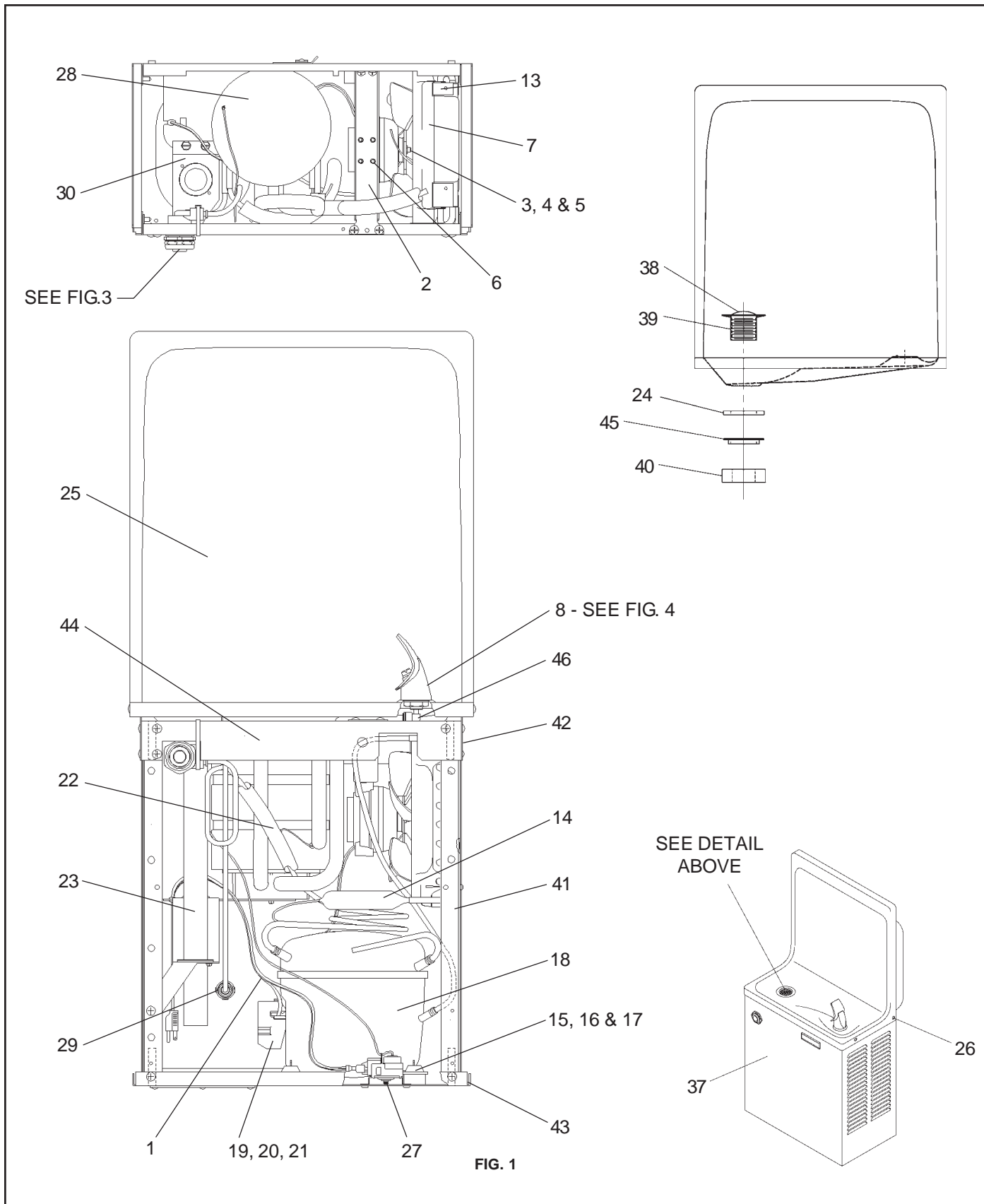

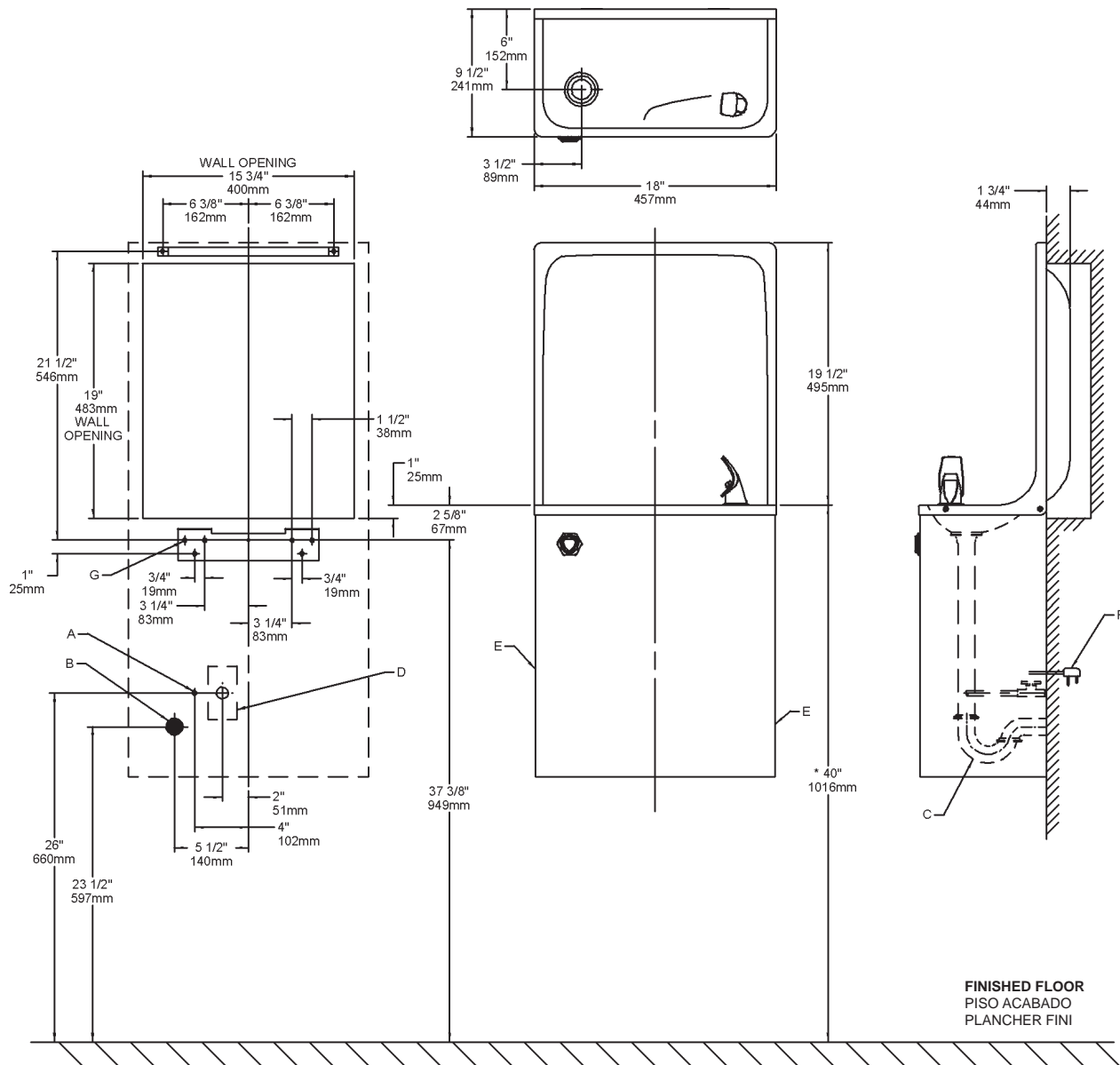

FIG. 2

\* RECOMMENDED HEIGHT FOR ADULTS.  
DECREASE HEIGHT FOR CHILDREN.  
\* ALTURA RECOMENDADA PARA ADULTOS.  
REDUZCA PARA LOS NIÑOS.  
\* HAUTEUR RECOMMANDÉE POUR LES  
ADULTES. INSTALLEZ PLUS BAS POUR  
LES ENFANTS.

LEGEND/LEYENDA/LÉGENDE

**A = RECOMMENDED WATER SUPPLY LOCATION 3/8" O.D. UNPLATED COPPER TUBE CONNECT STUB 1-1/2" IN. (38 mm) OUT FROM WALL SHUT OFF BY OTHERS**

SE RECOMIENDA UBICAR EL TUBO CORTO DE CONEXIÓN AL TUBO DE COBRE SIN CHAPAR DE 3/8" DE DIÁM. EXT. A 1-1/2" (38 mm) FUERA DE LA LLAVE DE PASO EN LA PARED COLOCADA POR TERCEROS.  
EMPLACEMENT RECOMMANDÉ D'ALIMENTATION EN EAU PAR TUBE EN CUIVRE NON PLAQUÉ DE 3/8 PO. (9,5 mm) D.E. CONNECTANT UNE TUYAUTERIE DE 1-1/2 PO. (38 mm) DEPUIS LE ROBINET D'ARRÊT FOURNI PAR D'AUTRES.

**B = RECOMMENDED LOCATION FOR WASTE OUTLET 1-1/4" O.D. DRAIN**  
UBICACIÓN RECOMENDADA PARA EL DRENAJE DE SALIDA DE AGUA, DE 1 1/4" DE DIÁMETRO.  
EMPLACEMENT RECOMMANDÉ POUR LE DRAIN DE D.E. 1-1/4" DE SORTIE D'EAU.

**C = 1-1/4" TRAP NOT FURNISHED\*\***  
PURGADOR DE 1 1/4" NO PROPORCIONADO\*\*  
SIPHON 1-1/4" NON FOURNI\*\*

**D = ELECTRICAL OUTLET LOCATION**  
UBICACIÓN DE LA TOMA DE ELECTRICIDAD  
EMPLACEMENT DE LA PRISE DE COURANT

**E = INSURE PROPER VENTILATION BY MAINTAINING 4" (102mm) (MIN.) CLEARANCE FROM CABINET LOUVERS TO WALL.**  
ASEGURE UNA VENTILACIÓN ADECUADA MANTENIENDO UN ESPACIO E 4" (102mm) (MÍN.) DE HOLGURA ENTRE LA REJILLA DE VENTILACIÓN DEL MUEBLE Y LA PARED  
ASSUREZ-VOUS UNE BONNE VENTILATION EN GARDANT 4" (102mm) (MIN.) ENTRE LES ÉVENTS DE L'ENCEINTE ET LE MUR.

**F = POWER CORD 1-1/2 FEET (457mm) LONG**  
CABLE ELÉCTRICO DE 1 1/2' PIE, 457 mm DE LARGO  
CORDON D'ALIMENTATION 1-1/2' (457mm)

**G = 5/16" (8mm) SCREW HOLES IN MOUNTING PLATE**  
AGUJEROS DE TORNILLO 5/16" (8mm) EN LA PLACA DE MONTAJE  
TROUS DE VIS 5/16" (8mm) DANS LA PLAQUE DE MONTAGE

**IMPORTANT**  
**ALL SERVICE TO BE PERFORMED BY AN AUTHORIZED SERVICE PERSON**

**HANGER BRACKETS & TRAP INSTALLATION**

- 1) Remove hanger brackets fastened to back of cooler by removing screws.
  - 2) Mount the hanger brackets and trap as shown in Figure 2.
- NOTE:** Hanger Brackets and trap **MUST** be supported securely. Add fixture support carrier if wall will not provide adequate support.
- IMPORTANT:**
- 5-1/2 in. (140mm) dimension from wall to centerline of trap must be maintained for proper fit.
  - Anchor hanger securely to wall using all mounting holes.
- 3) Install straight valve for 3/8" O.D. unplated copper tube.

**INSTALLATION OF COOLER**

- 4) Hang the cooler on the hanger brackets. Be certain the hanger brackets are engaged properly in the frame and wrapper.
- 5) Remove the access panel on the underside of the cooler and set it aside.
- 6) Connect water inlet line--See Note 4 of General Instructions.
- 7) Remove the slip nut and gasket from the trap and install them on the cooler waste line making sure that the end of the waste line fits into the trap. Assemble the slip nut and gasket to the trap and tighten securely.

**START UP**

**Also See General Instructions**

- 8) Replace the front panel and secure by retightening all screws.

Stream height is factory set at 35 PSI. If supply pressure varies greatly from this, remove items 31 and 32 and adjust screw on item 34. Clockwise adjustment will raise stream and counter-clockwise adjustment will lower stream. For best adjustment, stream should hit basin approximately 6-1/2" (165mm) from bubbler.

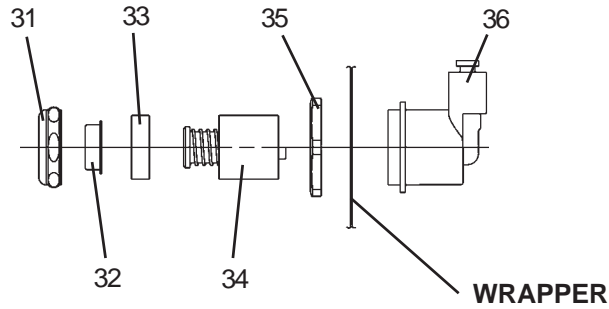

**FIG. 3**

**NOTE:**  
 WHEN INSTALLING REPLACEMENT BUBBLER AND PEDESTAL, TIGHTEN NUT (ITEM 12) ONLY TO HOLD PARTS SNUG IN POSITION.  
 DO NOT OVER TIGHTEN.

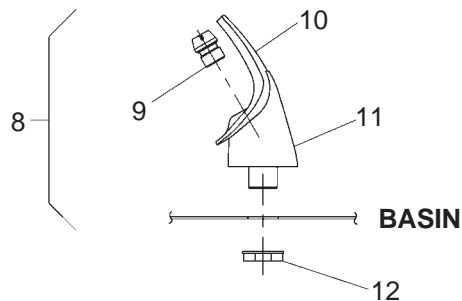

**FIG. 4**

**PARTS LIST**

ITEM NO.	PART NO.	DESCRIPTION
1	36208C	Power Cord
2	27095C	Fan Bracket
3	30664C	Fan Blade
4	70018C	Hex Nut - Fan Blade
5	31490C	Fan Motor
6	70009C	Screw (Fan Motor)
7	56237C	Shroud - Fan
8	56073C	Bubbler Assy
9	40322C	Orifice Assy
10	56011C	Housing Assy
11	55997C	Pedestal
12	75580C	Locknut
13	66743C	Condenser
14	66703C	Drier
15	50144C	Grommet - Compressor Mtg.
16	70184C	Hair Pin - Cotter
17	70418C	Washer
18*	36094C	Compressor Serv. Pak EMI 70 HNR
19	36158C	Overload
20	35768C	Cover - Relay
21	35959C	Relay
22	66576C	Heat Exchanger
23	40041C	Tailpipe Assy (8 Gal)
	40429C	Precooler Assy (13 Gal)
24	50074C	Tailpipe Gasket
25	20593C	Basin - Stainless Steel
	20594C	Basin - Glass Filler
26	75536C	Screw - Basin Mtg.
27	31513C	Cold Control
28	66534C	Evaporator Assembly
29	55996C	Strainer
30	27239C	Bracket - Precooler
31	40089C	Cover
32	40048C	Button
33	15005C	Retaining Nut
34	61313C	Regulator
35	40169C	Hex Nut
36	50986C	Regulator Holder
37	See Color Table	Wrapper
38	40038C	Strainer - Beehive
39	40619C	Ferrule - Tailpipe
40	50105C	Tailpipe Gasket
41	27093C	Angle-Front Corner
42	27292C	Bracket-Basin Mounting
43	27097C	Frame-Back/Bottom
44	27094C	Bracket-Front
45	40043C	Locknut
46	70817C	Fitting-Elbow 1/4 Stem
47	15009C	Nipple - Bubbler (GF)
48	100322740560	Gasket
49	31525028	O-Ring
50	40493C	Glass Filler
NS	56092C	Poly Tubing (Cut to Length)

**COLOR TABLE**

PANEL COLOR	Item No. 37 Part No.
Gray Beige	21017C
Almond	21481C
Stainless Steel	21013C
Sandalwood	21480C
Granite	27208C
Light Gray	27209C

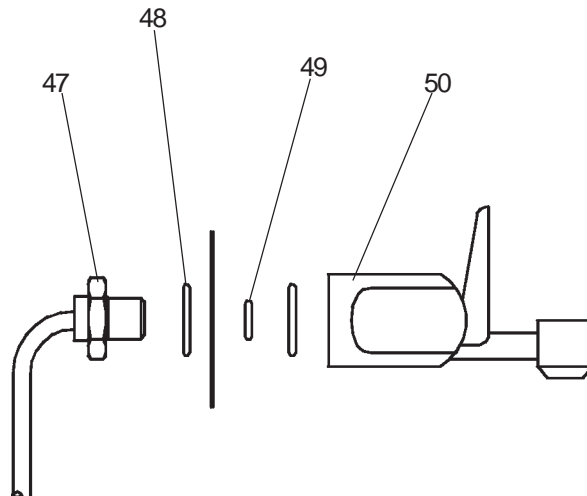

**FIG. 5**

**\*INCLUDES RELAY & OVERLOAD. IF UNDER WARRANTY, REPLACE WITH SAME COMPRESSOR USED IN ORIGINAL ASSEMBLY.**

NOTE: All correspondence pertaining to any of the above water coolers or orders for repair parts MUST include Model No. and Serial No. of cooler, name and part number of replacement part.