

**ELKAY** With FLEXI-GUARD<sup>®</sup>  
**INSTALLATION, CARE & USE MANUAL**

*EWHA Pressure Cooler with FLEXI-GUARD<sup>™</sup>*  
*USES HFC-134A REFRIGERANT*

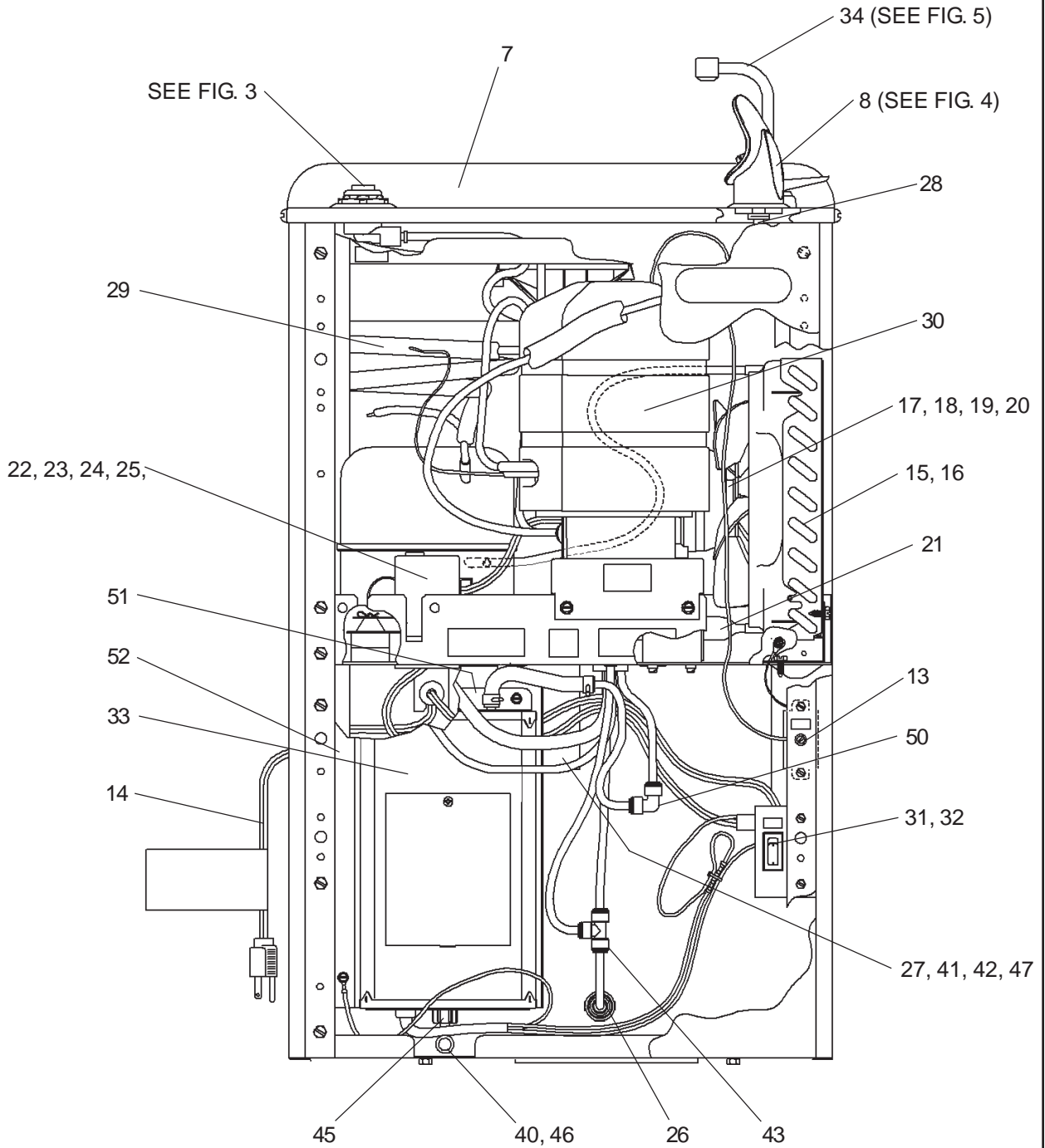
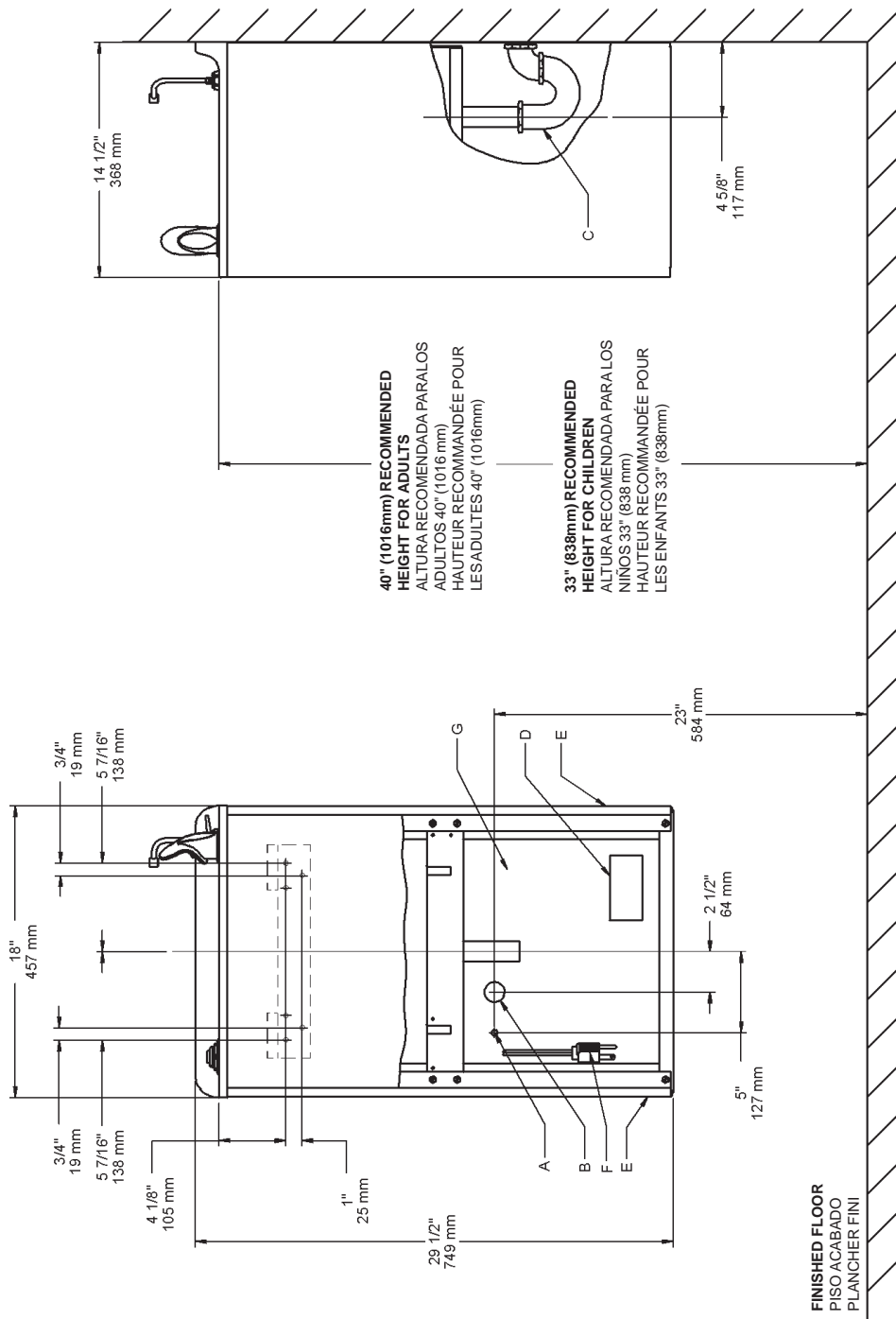

FIG. 1



**40" (1016mm) RECOMMENDED HEIGHT FOR ADULTS**  
 ALTURA RECOMENDADA PARALOS ADULTOS 40" (1016 mm)  
 HAUTEUR RECOMMANDÉE POUR LES ADULTES 40" (1016mm)

**33" (838mm) RECOMMENDED HEIGHT FOR CHILDREN**  
 ALTURA RECOMENDADA PARALOS NIÑOS 33" (838 mm)  
 HAUTEUR RECOMMANDÉE POUR LES ENFANTS 33" (838mm)

**FINISHED FLOOR**  
 PISO ACABADO  
 PLANCHER FINI

**FIG. 2**

- LEGEND/LEYENDA/LÉGENDE**
- A = RECOMMENDED WATER SUPPLY LOCATION 3/8 O.D. UNPLATED COPPER TUBE CONNECT STUB OUT 1-1/2 IN. (38mm) FROM WALL SHUT OFF BY OTHERS**  
 SE RECOMIENDA UBICAR EL TUBO CORTO DE CONEXIÓN AL TUBO DE COBRE SIN CHAPAR DE 3/8" DE DIÁM. EXT. A 1-1/2" (38 mm) FUERA DE LA Llave DE PASO EN LA PARED COLOCADA POR TERCEROS.  
 EMPLACEMENT RECOMMANDÉ D'ALIMENTATION EN EAU PAR TUBE EN CUIVRE NON PLAQUÉ DE 3/8 PO. (9.5 mm) D.E. CONNECTANT UNE TUYAUTERIE DE 1-1/2 PO. (38 mm) DEPUIS LE ROBINET D'ARRÊT FOURNI PAR D'AUTRES.
  - B = RECOMMENDED LOCATION FOR WASTE OUTLET 1-1/4" O.D. DRAIN**  
 UBICACIÓN RECOMENDADA PARA EL DRENAJE DE SALIDA DE AGUA. DE 1 1/4" DE DIÁMETRO.  
 EMPLACEMENT RECOMMANDÉ POUR LE DRAIN DE D.E. 1-1/4" DE SORTIE D'EAU.
  - C = 1-1/4 TRAP NOT FURNISHED**  
 PURGADOR DE 1 1/4 NO PROPORCIONADO  
 SIPHON 1-1/4 NON FOURNI
  - D = ELECTRICAL OUTLET LOCATION**  
 UBICACIÓN DE LA TOMA DE ELECTRICIDAD  
 EMPLACEMENT DE LA PRISE DE COURANT
  - E = INSURE PROPER VENTILATION BY MAINTAINING 4" (102mm) (MIN.) CLEARANCE FROM CABINET LOUVERS TO WALL.**  
 ASEGURE UNA VENTILACIÓN ADECUADA MANTENIENDO UN ESPACIO E 4" (102mm) (MIN.) DE HOLLGURA ENTRE LA REJILLA DE VENTILACIÓN DEL MUEBLE Y LA PARED  
 ASSUREZ-VOUS UNE BONNE VENTILATION EN GARDANT 4" (102mm) (MIN.) ENTRE LES ÉVÉNENTS DE L'ENCEINTE ET LE MUR.
  - F = POWER CORD 4 FEET (1219mm) LONG**  
 CABLE ELÉCTRICO DE 4 PIE (1219mm), DE LARGO  
 CORDON D'ALIMENTATION 4' (1219mm)
  - G = PLUMBING ROUGH-IN CAN BE LOCATED ANYWHERE WITHIN THIS AREA.**  
 SE PUEDE COLOCAR EL DESBASTE DE LA TUBERIA EN CUALQUIER LUGAR DENTRO DE ESTA AREA.  
 ON PEUT PLACER LA TUYAUTERIE DANS CETTE RÉGION.

Stream height is factory set at 35 PSI. If supply pressure varies greatly from this, remove Items 1 & 2 and adjust screw on Item 4. Clockwise adjustment will raise stream and counter-clockwise adjustment will lower stream. For best adjustment, stream should hit basin approximately 6-1/2" (165mm) from bubbler.

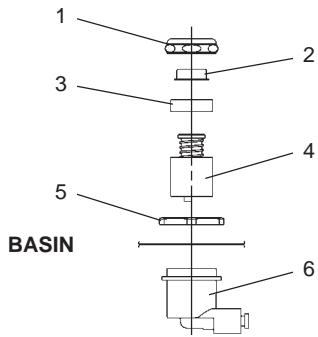
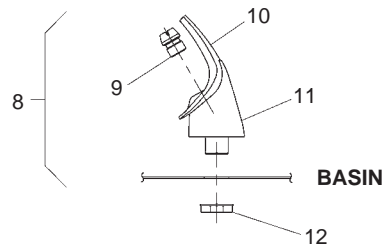

FIG. 3



**NOTE:**  
**WHEN INSTALLING REPLACEMENT BUBBLER AND PEDESTAL, TIGHTEN NUT (ITEM 12) ONLY TO HOLD PARTS SNUG IN POSITION. DO NOT OVER TIGHTEN.**

FIG. 4

**WIRING DIAGRAM**

This Drawing is merely for illustrating the components of the electrical system.

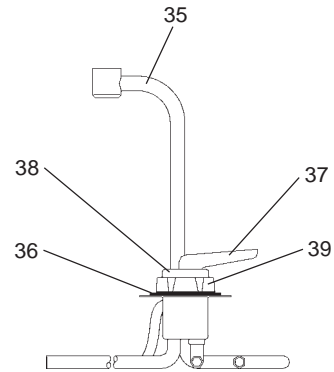
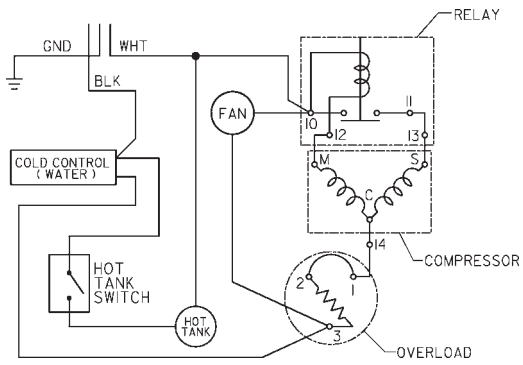

FIG. 5

PARTS LIST 115V		
ITEM NO.	PART NO.	DESCRIPTION
1	40089C	Cover
2	40048C	Button
3	15005C	Regulator Retaining Nut
4	61313C	Regulator
5	40169C	Hex Nut
6	50986C	Regulator Holder
7	21541C	Basin
	21539C	Basin (GF)
8	56073C	Bubbler Assy
9	40322C	Orifice Assy
10	56011C	Housing Assy
11	55997C	Pedestal
12	75580C	Bubbler Locknut
13	31513C	Cold Control
14	36132C	Power Cord
15	66743C	Condenser
16	56237C	Fan Shroud
17	31490C	Fan Motor
18	30664C	Fan Blade
19	27681C	Fan Bracket
20	70018C	Fan Blade Nut
21	66703C	Drier
*22	36094C	Compressor Serv. Pak
23	36158C	Overload
24	35768C	Relay Cover
25	35959C	Relay
26	55996C	Strainer
27	45448C	Tailpipe/Vacuum Break
28	56092C	Poly Tubing (Cut To Length)
29	66576C	Heat Exchanger
30	66534C	Evaporator
31	28427C	Hot Tank Switch Bracket
32	36101C	Hot Tank Switch
33	36204C	Hot Tank Assy
34	45820C	Hot Valve Assy
35	40597C	Gooseneck
36	33659000	Body Gasket
37	51543C	Handle
38	40596C	Shroud
39	70921C	Mounting Nut
40	70606C	Plug-Drain
41	50368C	Receptor-Drain
42	70750C	Clamp-Hose
43	70682C	Tee - 1/4 x 1/4 x 1/4
44	70683C	Union - 1/4
45	66736C	Tube - 5/16 to 1/4 Drain
46	75666C	Nut - Drain 5/16" Compression
47	50005C	Gasket - Drain
48	100322740560	Gasket (GF)
49	15009C	Nipple - Bubbler (GF)
50	70793C	Elbow - 1/4 x 90°
51	28438C	Bracket - Hot Tank Hold
52	28445C	Bracket - Hot Tank Mounting
N/S	70817C	Elbow - 1/4 Stem x 90°

230V 50/60 Hz

ITEM NO.	PART. NO.	DESCRIPTION
14	36131C	Power Cord
17	31430C	Fan Motor
22*	36085C	Compressor Serv. Pak
23	36195C	Overload
25	36050C	Relay
33	36205C	Hot Tank Assy
-	35826C	Power Inlet

\*INCLUDES RELAY & OVERLOAD. IF UNDER WARRANTY, REPLACE WITH SAME COMPRESSOR USED IN ORIGINAL ASSEMBLY.  
NOTE: All correspondence pertaining to any of the above water coolers or orders for repair parts MUST include Model No. and Serial No. of cooler, name and part number of replacement part.

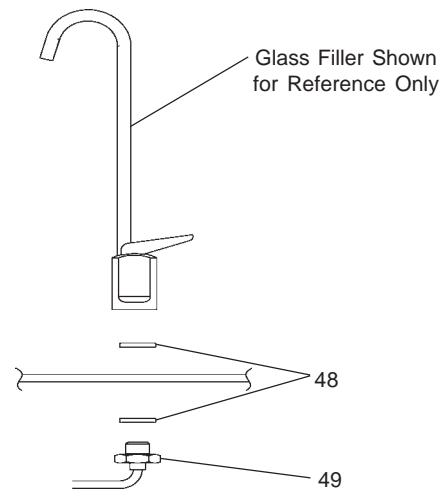

FIG. 7

COLOR TABLE	LEFT PANEL	RIGHT PANEL (w/o hole)	RIGHT PANEL (w/ hole)	FRONT PANEL
Gray Beige	20638C	21526C	20639C	20675C
Almond	21464C	21530C	21465C	20676C
Stainless Steel	20640C	21527C	20641C	20672C
Sandalwood	21462C	21528C	21463C	21454C
Granite	27171C	27192C	27174C	27150C
Light Gray Granite	27172C	N/A	27175C	21455C