

Installation, Care & Use Manual

Uses HFC-134A Refrigerant

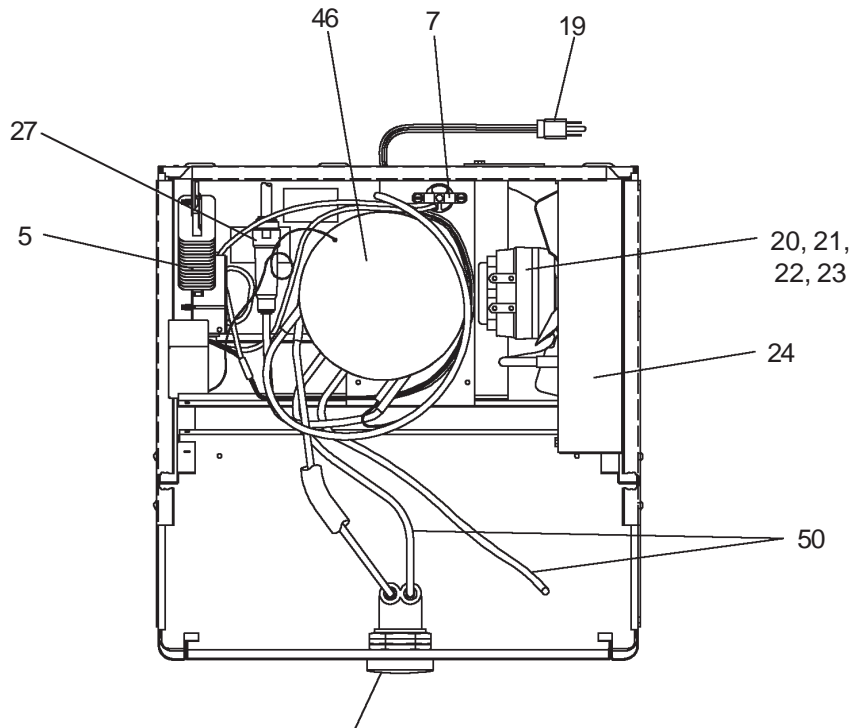

SEE FIG. 3

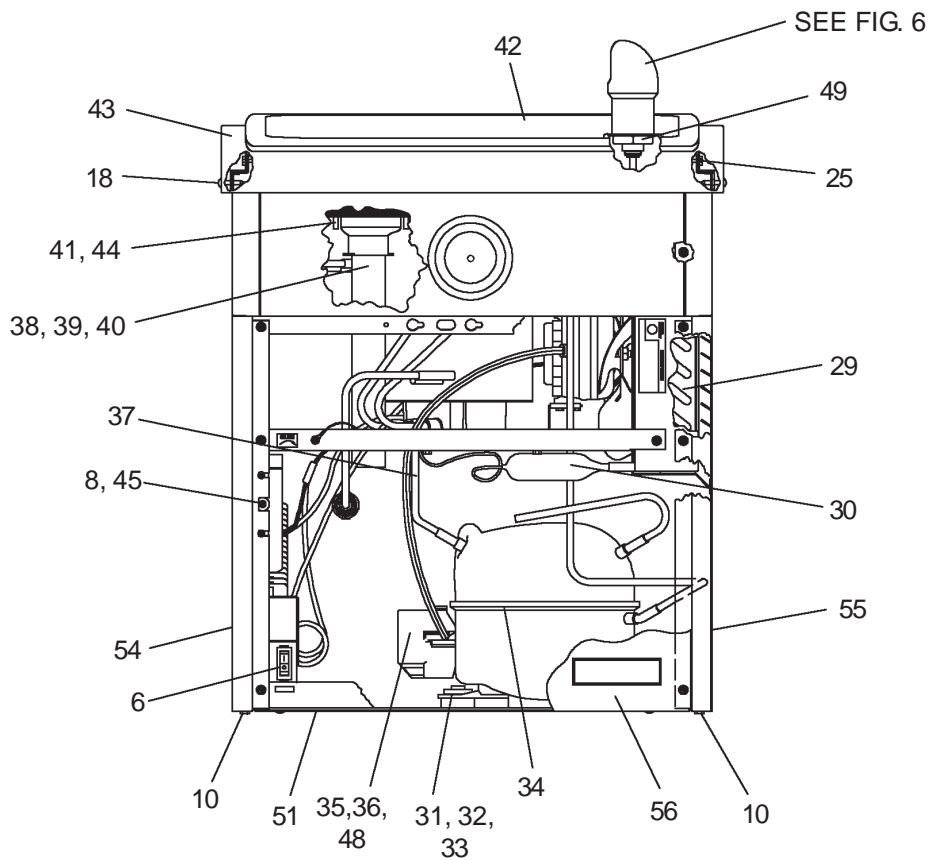

FIG. 1

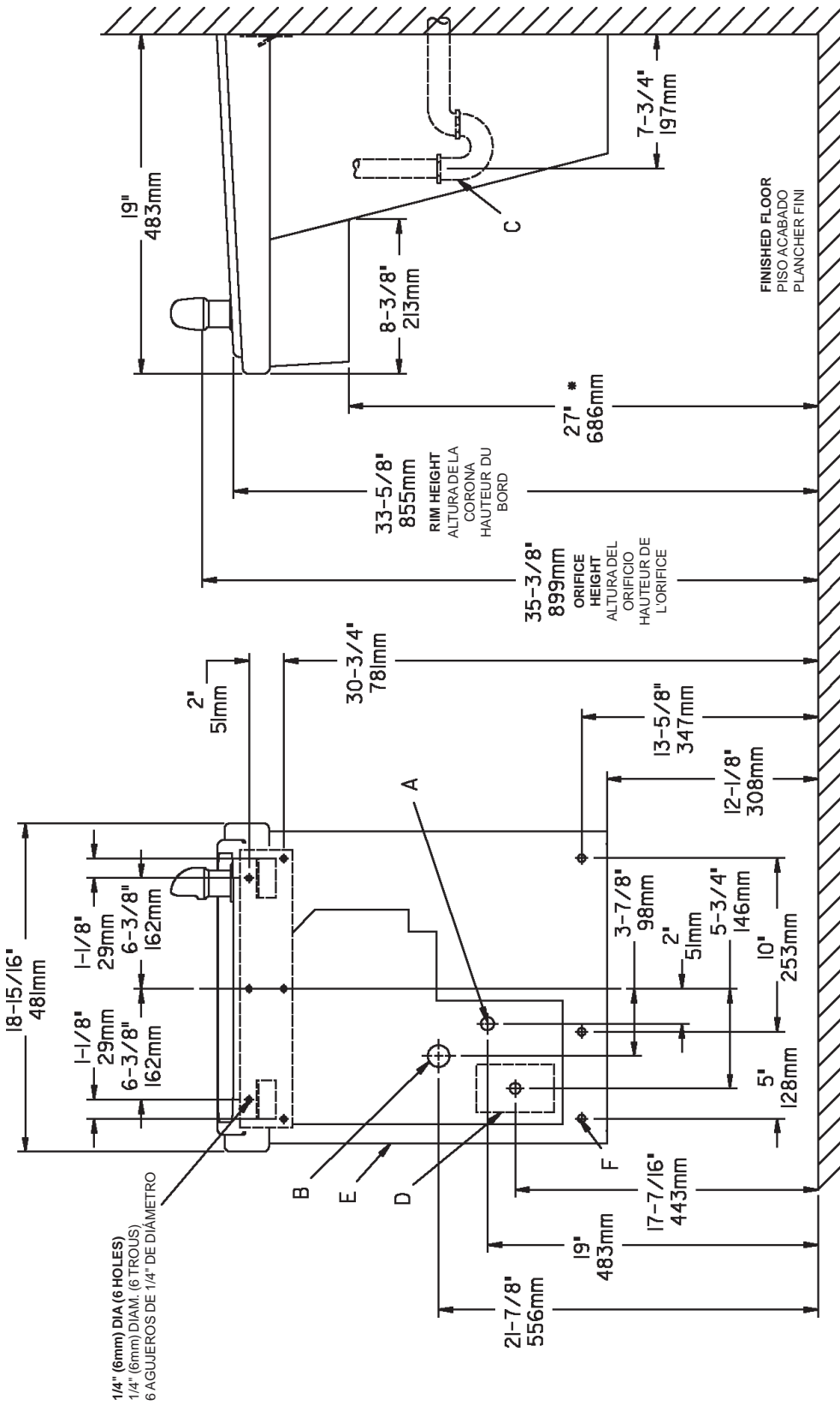

FIG. 2

LEGEND/LEYENDA/LÉGENDE

- A = RECOMMENDED WATER SUPPLY LOCATION 3/8 O.D. UNPLATED COPPER TUBE CONNECT STUB 1-1/2 IN. (38mm) OUT FROM WALL SHUT OFF BY OTHERS.**
SE RECOMIENDA UBICAR EL TUBO CORTO DE CONEXIÓNAL TUBO DE COBRE SIN CHAPAR DE 3/8" DE DIAM. EXT. A 1-1/2" (38mm) FUERA DE LA PARED COLOCADA POR TERCEROS.
EMPLACEMENT RECOMMANDÉ D'ALIMENTATION EN EAU PAR TUBE EN CUIVRE NON PLAQUÉ DE 3/8 PO. (9.5 mm) D.E. CONNECTANT UNE TUYAUTERIE DE 1-1/2 PO. (38mm) DEPUIS LE ROBINET D'ARRÊT FOURNI PAR D'AUTRES.
- B = RECOMMENDED LOCATION FOR WASTE OUTLET 1-1/4" O.D. DRAIN**
UBICACIÓN RECOMENDADA PARA EL DRENAJE DE SALIDA DE AGUA, DE 1 1/4" DE DIÁMETRO.
EMPLACEMENT RECOMMANDÉ POUR LE DRAIN DE D.E. 1-1/4" DE SORTIE D'EAU.
- C = 1-1/4 TRAP NOT FURNISHED***
PURGADOR DE 1 1/4" NO PROPORCIONADO*
- D = ELECTRICAL SUPPLY (3) WIRE RECESSED BOX**
CAJA RECESIVA DE ALAMBRES (3) DE SUMINISTRO ELÉCTRICO
- E = INSURE PROPER VENTILATION BY MAINTAINING 6" (152 mm) (MIN.) CLEARANCE FROM CABINET LOUVERS TO WALL.**
ASEGURE UNA VENTILACION ADECUADA MANTENIENDO UN ESPACIO 6" (152 mm) (MIN.) DE HOLGURA ENTRE LA REJILLA DE VENTILACIÓN DEL MUEBLE Y LA PARED
- F = 7/16 BOLT HOLES FOR FASTENING UNIT TO WALL**
AGUJEROS DE LAS TUERCAS DE 7/16 PARA SUJETAR LA UNIDAD A LA PARED

*ADA REQUIREMENT
*REQUISITO DE A.D.A.
*EXIGENCE ADA

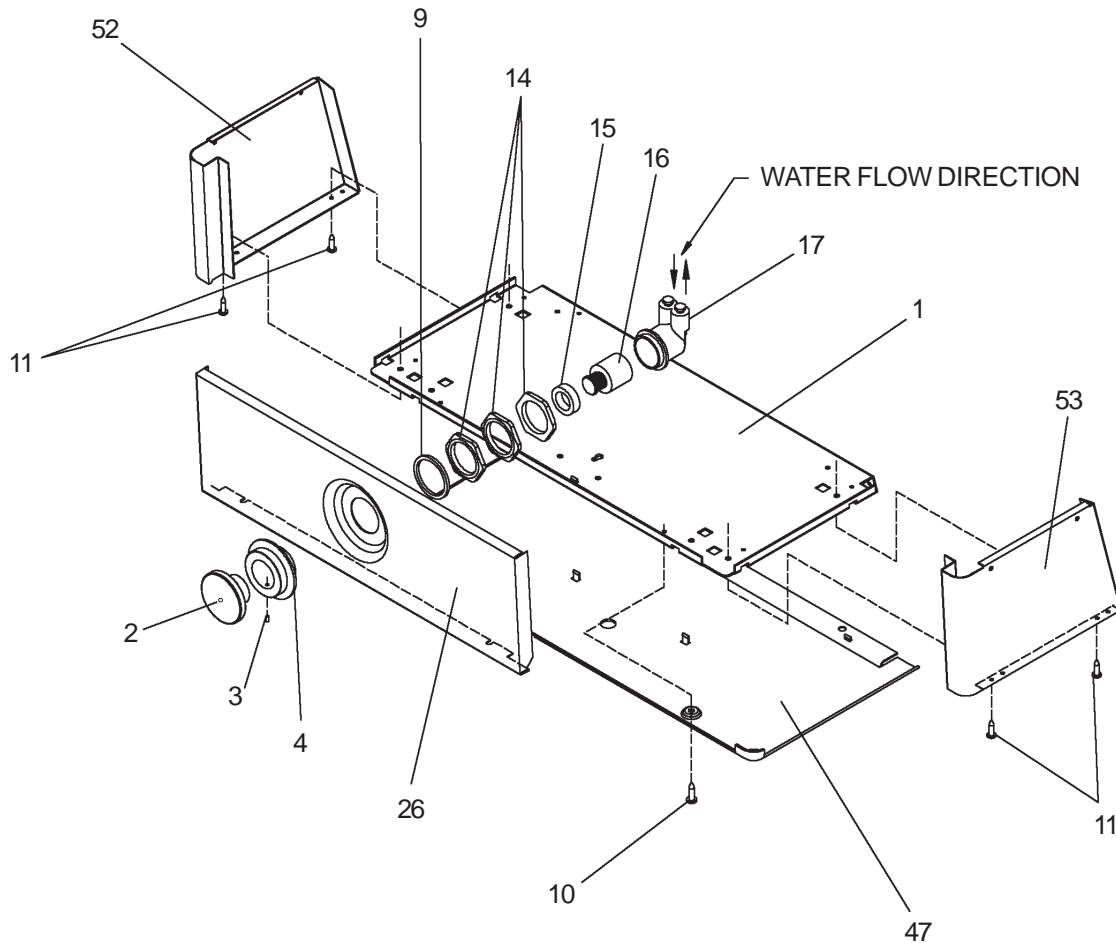

FIG. 3

IMPORTANT
ALL SERVICE TO BE PERFORMED BY AN AUTHORIZED SERVICE PERSON

HANGER BRACKETS AND TRAP INSTALLATION

- 1) Remove hanger bracket fastened to back of cooler by removing one screw.
- 2) Mount the hanger bracket and trap as shown in Figure 2.

NOTE: Hanger Bracket **MUST** be supported securely. Add fixture support carrier if wall will not provide adequate support.
IMPORTANT:

- 7-3/4 in. (197mm) dimension from wall to centerline of trap must be maintained for proper fit.
 - Anchor hanger securely to wall using all six 1/4 in. dia. mounting holes.
- 3) Install straight valve for 3/8" O.D. tube.

INSTALLATION OF COOLER

- 4) Hang the cooler on the hanger bracket. Be certain the hanger bracket is engaged properly in the slots on the cooler back.
- 5) Loosen the two screws holding the lower front panel at the bottom of cooler base. Pull front panel forward to gain access inside cooler.
- 6) Connect water inlet line - See Note 4 of General Instructions.
- 7) Remove the slip nut and gasket from the trap and install them on the cooler water line making sure that the end of the waste line fits into the trap. Assemble the slip nut and gasket to the trap and tighten securely.

START UP

Also See General Instructions

- 8) Stream height is factory set at 35 PSI. If supply pressure varies greatly from this, adjust the screw on regulator item 16 by using a small screwdriver through the small hole in the push button item 2 (See Fig.3). Clockwise adjustment will raise stream and counter-clockwise adjustment will lower stream. For best adjustment, stream should hit basin approximately 6-1/2" (165mm) from bubbler.

PROTECT FROM HARD FREEZING

- 9) If the ambient air temperature drops below 0° F, the cooler needs to be drained of all water by blowing out all water lines, evaporator (item 46), and the drain trap.

PARTS LIST

ITEM NO	PART NO	DESCRIPTION
1	22897C	Panel - Bottom Dispenser
2	45662C	Button - Push
3	75672C	Screw - Cap
4	45663C	Sleeve - Push Button
5	35906C	Heater Strip
6	35907C	Switch - Rocker
7	35909C	Heater Thermostat Assy
8	27124C	Cover - Cold Control
9	56033C	Washer
10	75500C	Screw - Torx
11	70864C	Screw - #8 x 5/8" Lg. Torx/Slot
12	27469C	Panel - Screen
13	75566C	Screw - Torx
14	40045C	Hex Nut
15	15005C	Retaining - Nut
16	61313C	Regulator
17	50986C	Holder - Regulator
18	75532C	Screw
19	35900C	Power Cord
20	30664C	Fan Blade
21	70018C	Hex Nut - Fan Blade
22	31490C	Fan Motor
23	70009C	Screw - (Fan Motor)
24	22899C	Shroud - Fan
25	38417001	Screw - #8-18 x 3/8" HHSM
26	27295C	Panel - Front Dispenser
27	55996C	Strainer
28	98118C	Bubbler Assembly
29	62152C	Condenser
30	66202C	Drier
31	101516143550	Stud - Compressor Mtg.
32	100806740570	Grommet - Compressor Mtg.
33	19037000	Clip - Compressor Mtg.
*34	36094C	Compressor Serv. Pak EMI 70 HNR
35	35959C	Relay
36	35768C	Cover - Relay
37	66576C	Heat Exchanger
38	40614C	Drain Tube
39	50400C	Gasket - Drain
40	50401C	Ring Support - Drain
41	70444C	Clamp - Drain Gasket
42	21903C	Basin - Stainless Steel
43	27306C	Adaptor - Basin
44	70016C	Hex Nut #10-32
45	31513C	Cold Control
46	66534C	Evaporator Assembly
47	55931C	Cover-Dispenser Bottom Gray
48	36158C	Overload
49	15009C	Bubbler - Nipple
50	56092C	Poly Tubing (Cut To Length)
51	26999C	Cover - Bottom
52	22814C	Panel - LH No Push
53	22822C	Panel - RH No Push
54	22854C	Panel - LH Rear
55	22862C	Panel - RH Rear
56	22955C	Panel - Front Lower
57	100322740560	Gasket
NS	400660943730	Hanger Bracket
NS	75519C	Bit - Pinned Torx T-15
NS	75520C	Bit - Pinned Torx T-25
NS	75674C	Wrench - Allen 7/64

REPAIR SERVICE INFORMATION TOLL FREE NUMBER 1-800-260-6640
 NÚMERO GRATIS DE SERVICIO 1-800-260-6640
 INFORMATIONS POUR LE SERVICE PAR NUMERO SANS FRAIS 1-800-260-6640

***REPLACE WITH SAME COMPRESSOR USED IN ORIGINAL ASSEMBLY.**

NOTE: All correspondence pertaining to any of the above water coolers or orders for repair parts **MUST** include Model No. and Serial No. of cooler, name and part number of replacement part.

WARNING!

This unit is frost resistant down to 0° F with no wind. Prevailing winds can reduce the ability of the heater element to prevent light freezing. If the ambient air temperature will drop below 0° F, the cooler needs to be drained of all water by blowing out all water lines, evaporator (item 49), and the drain trap. A heater strip is used to heat the unit and will begin to cycle at 40° +/- 5° F. A check at this temperature will ensure the heater is working and the unit is resistant to light freezing.

ALSO, MAKE SURE THERE ARE NO PLASTIC OR FLAMMABLE COMPONENTS DIRECTLY ABOVE THE HEATER STRIP.

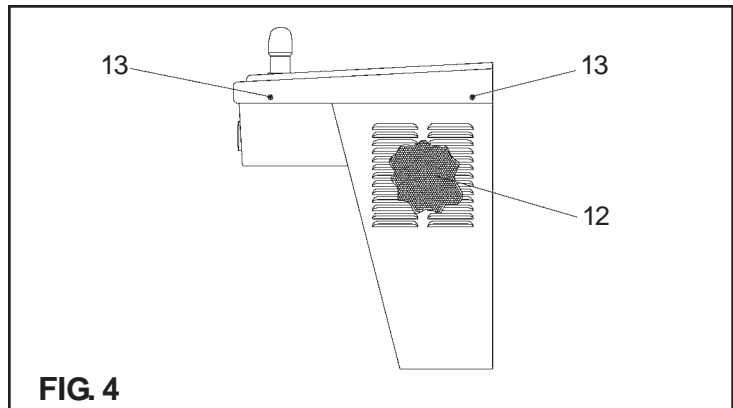

FIG. 4

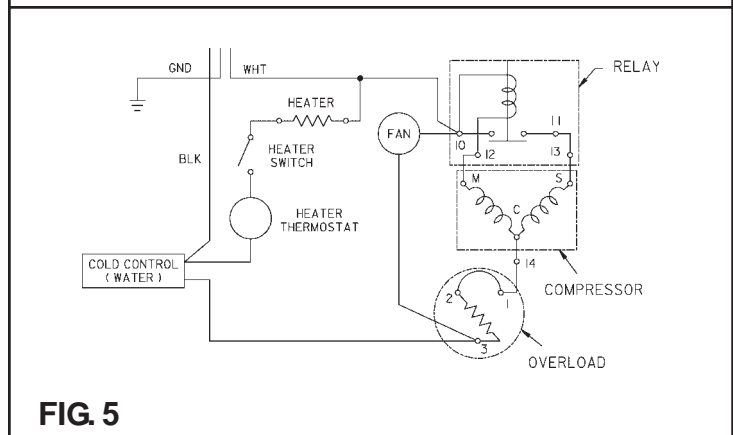

FIG. 5

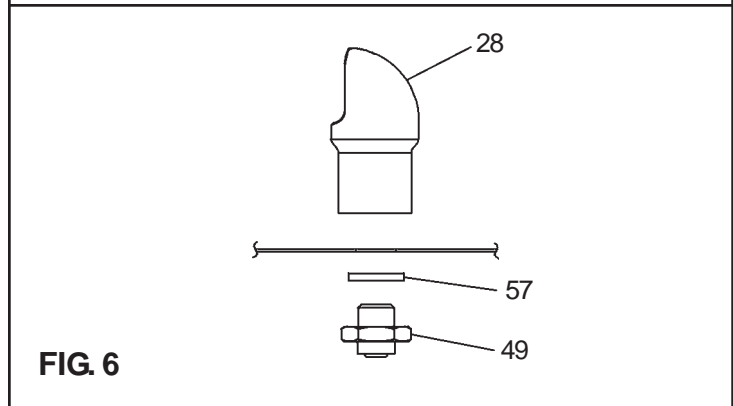

FIG. 6